

1532

BLAST MACHINE

The "Stubbie".

Lightest pot for it's size at just 60kg.

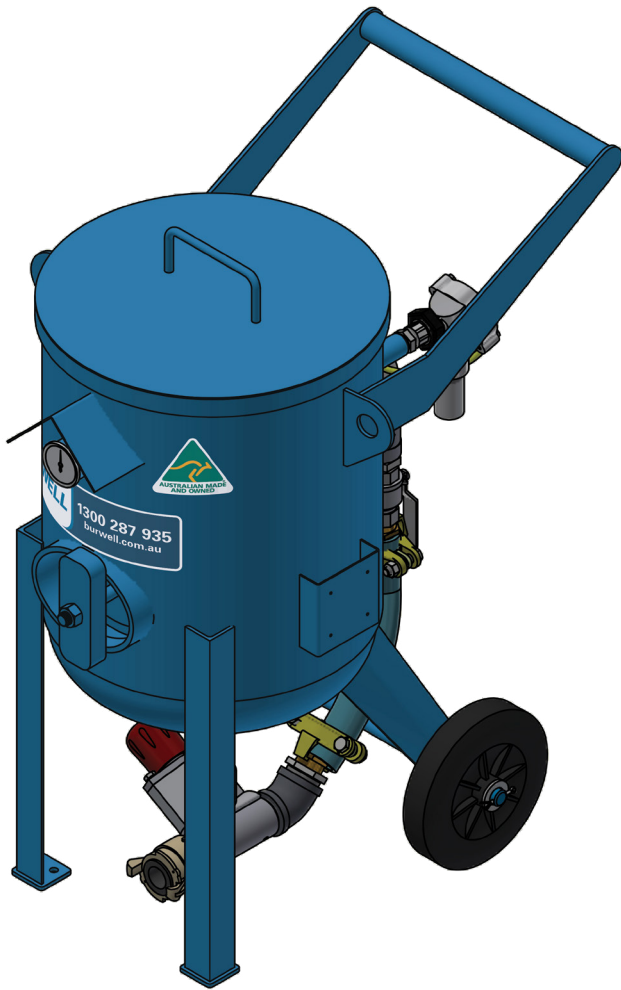

AUSTRALIAN MADE

Designed and made in Australia to AS1210 using Australian Plate Steel.



BUILT TOUGH

Rated to 175 psi (1205 kPa) to meet all situations.



SAFE

Rated lifting lugs make handling and transport safer and easier.



STABLE

Lower height to reduce risk of tipping and four points of contact for maximum stability.



PERFORMANCE

Valving system designed to minimise pressure drop.



PROTECTED

Valves are positioned to minimise the chance of damage.

Specifications

Useable Garnet Capacity: 75kg
Vessel diameter: 380mm
Weight: 60kg
Length: 725mm
Width: 525mm
Height: 885mm
Volume: 55 litres (2 cu ft)

Inclusions

Screen & Lid
1/2" Dump Valve
1-1/4" Micromiser Valve
1" Auto Air Valve
10m Deadman Control Line
Pneumatic Deadman Trigger
MDR & Australian Design Registration Certificate

Part Number

0131-1532-10

Description

Standard 1532 Blast Machine

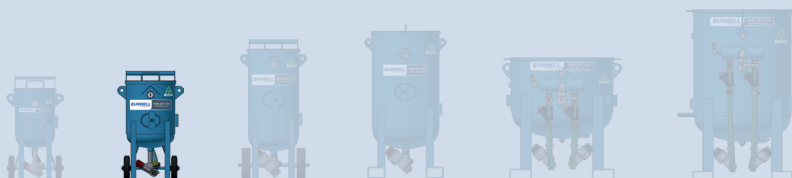
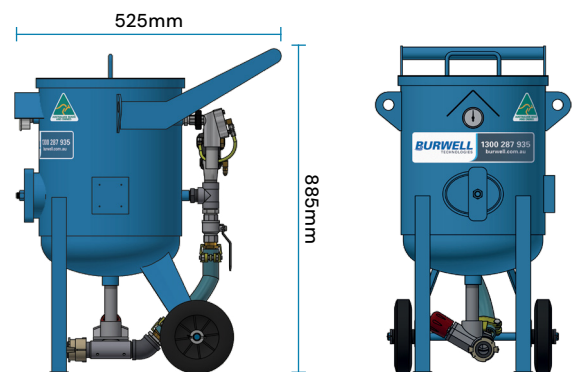

BURWELL

1300 287 935 burwell.com.au

Version 240602