

1642CP BLAST MACHINE

The "Trigger Happy Portable Workhorse."

Constant pressure allows for continuous blasting. Less stopping and starting on air compressor, reduced fuel or power consumption and less wear on blast pot components.



AUSTRALIAN MADE

Designed and made in Australia to AS1210 using Australian Plate Steel.



CONSTANT PRESSURE

Continuous blasting, less wear and tear and reduced energy consumption.



BUILT TOUGH

Rated to 175 psi to meet all situations.



STABLE

Four points of contact for maximum stability.



SAFE

Rated lifting lugs to make handling and transport safer and easier.



PERFORMANCE

Valving system designed to minimise pressure drop.



EASY TO LOAD

Low height of 1180mm makes it easier to load and handle.

Specifications

Useable Garnet Capacity: 175kg
Vessel diameter: 405mm
Weight: 145kg
Length: 780mm
Width: 580mm
Height: 1180mm
Volume: 90 litres (3.2 cu ft)

Option

Pneumatic Deadman Trigger

Inclusions

Screen & Lid
Thompson II Valve
1-1/4" Auto Air Valve
20m Deadman Control Line
ECK Electric Deadman Trigger

Part Number

0152-1642-30
0151-1642-30

Description

Constant Pressure 1642 Blast Machine - Electric
Constant Pressure 1642 Blast Machine - Pneumatic

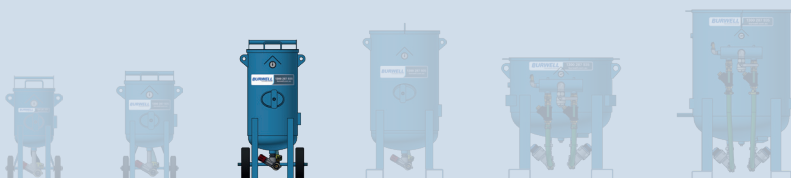
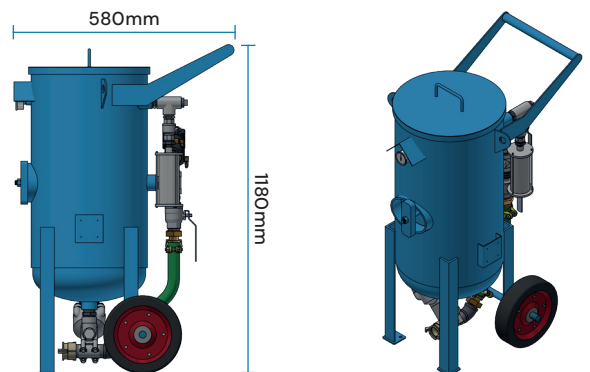

BURWELL

1300 287 935 burwell.com.au