

2449

BLAST MACHINE

The "Contractor's Choice."

Suitable for industrial projects and blast room applications.

Up to 120 minutes of blast time.

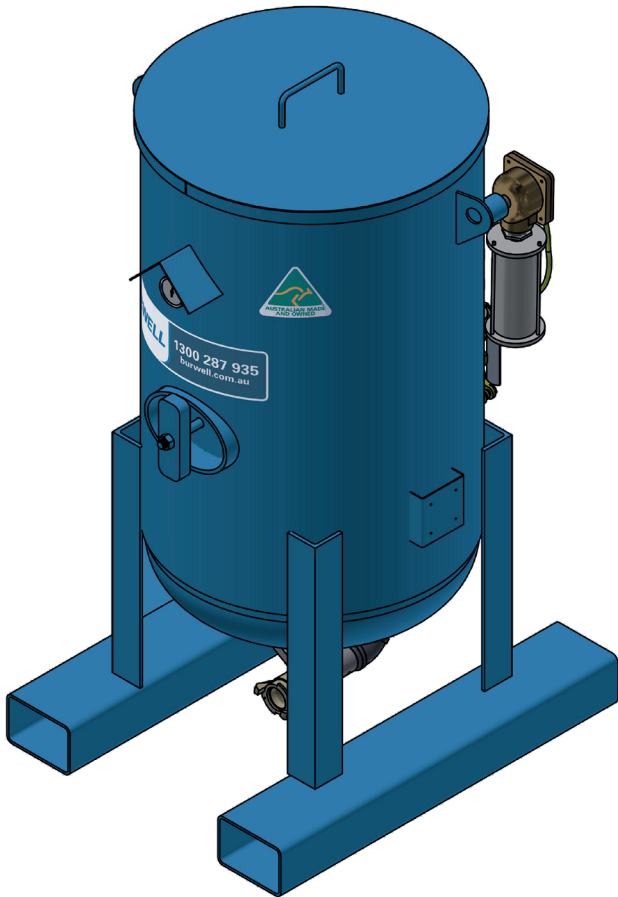

AUSTRALIAN MADE

Designed and made in Australia to AS1210 using Australian Plate Steel.



BUILT TOUGH

Rated to 175 psi (1205 kPa) to meet all situations.



SAFE

Rated lifting lugs to make handling and transport safer and easier.



TRANSPORT READY

Rated lifting lugs to make handling and transport safer and easier.



PERFORMANCE

Valving system designed to minimise pressure drop.



SITE READY

Forklift slots comply with Australian safety and site standards.

Specifications

Useable Garnet Capacity: 400kg
 Vessel diameter: 610mm
 Weight: 175kg
 Length: 845mm
 Width: 700mm
 Height: 1330mm
 Volume: 185 litres (6.5 cu ft)

Inclusions

Screen & Lid
 1" Dump Valve & Silencer
 1-1/4" Micromiser Valve
 1-1/4" Auto Air Valve
 20m Deadman Control Line
 Pneumatic Deadman Trigger
 MDR & Australian Design Registration Certificate

Part Number

0191-2449-10

Description

Standard 2449 Blast Machine

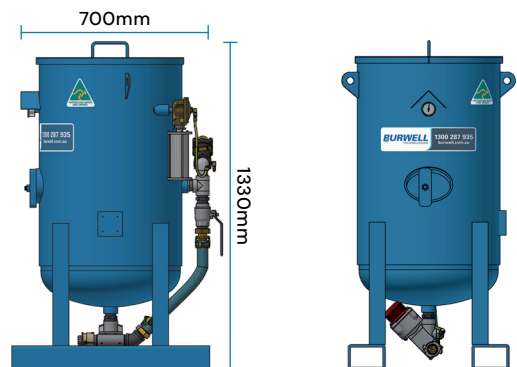

BURWELL

1300 287 935 burwell.com.au

Version 240602