

2449CP

BLAST MACHINE

The "Trigger Happy Contractor's Choice."

Constant pressure allows for continuous blasting. Less wear and tear on air compressor, reduced fuel or power consumption and less wear of blast pot components.

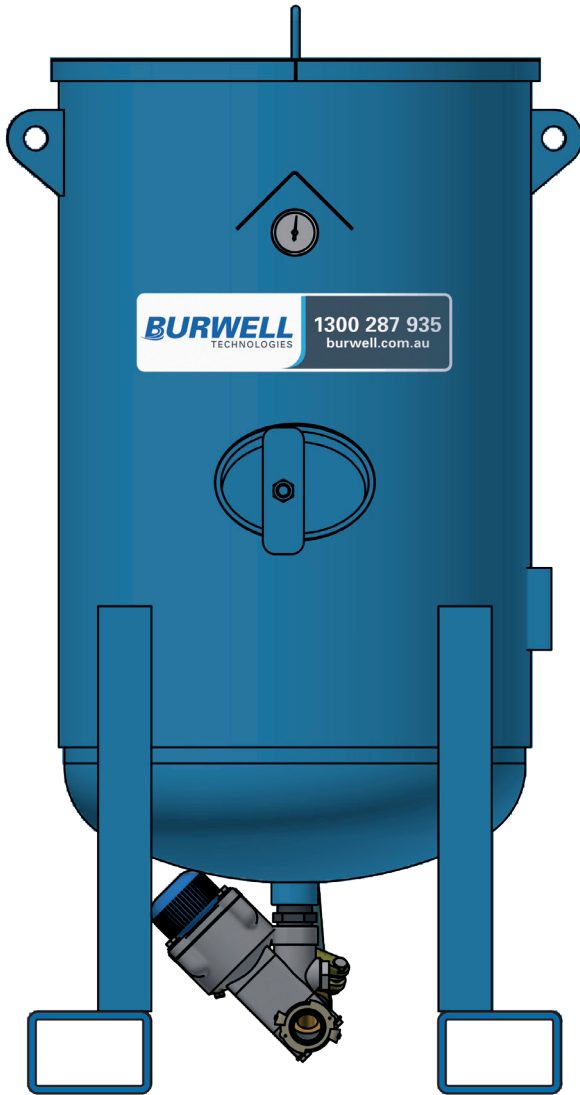

AUSTRALIAN MADE

Designed and made in Australia to AS1210 using Australian Plate Steel.



CONSTANT PRESSURE

Continuous blasting, less wear and tear and reduced energy consumption.



BUILT TOUGH

Rated to 175 psi to meet all situations.



SAFE

Rated lifting lugs to make handling and transport safer and easier.



PERFORMANCE

Valving system designed to minimise pressure drop.



TRANSPORT READY

Rated lifting lugs to make handling and transport safer and easier.



SITE READY

Forklift slots comply with Australian safety and site standards.

Specifications

Useable Garnet Capacity: 400kg
 Vessel diameter: 610mm
 Weight: 175kg
 Length: 845mm
 Width: 700mm
 Height: 1330mm
 Volume: 185 litres (6.5 cu ft)

Inclusions

Screen & Lid
 Thompson II Valve
 1-1/4" Auto Air Valve
 20m Deadman Control Line
 ECK Electric Deadman Trigger

Option

Pneumatic Deadman Trigger

Part Number

Description

0152-2449-30	Constant Pressure 2449 Blast Machine - Electric
0151-2449-30	Constant Pressure 2449 Blast Machine - Pneumatic

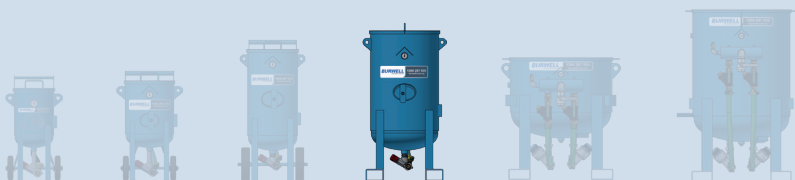
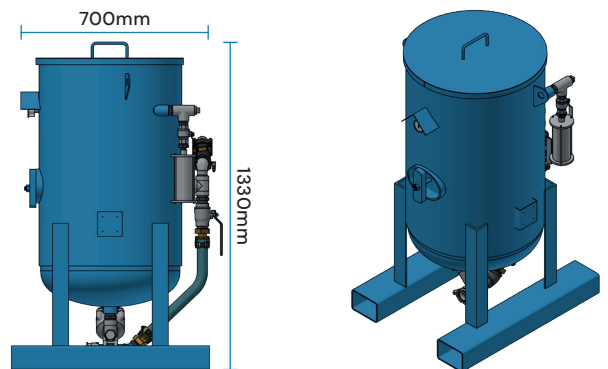

BURWELL

1300 287 935 burwell.com.au