

# 400

## AIR DRYER

# BREEZE PRO

Our smallest air dryer designed to be used with Single Outlet Blast Machines.

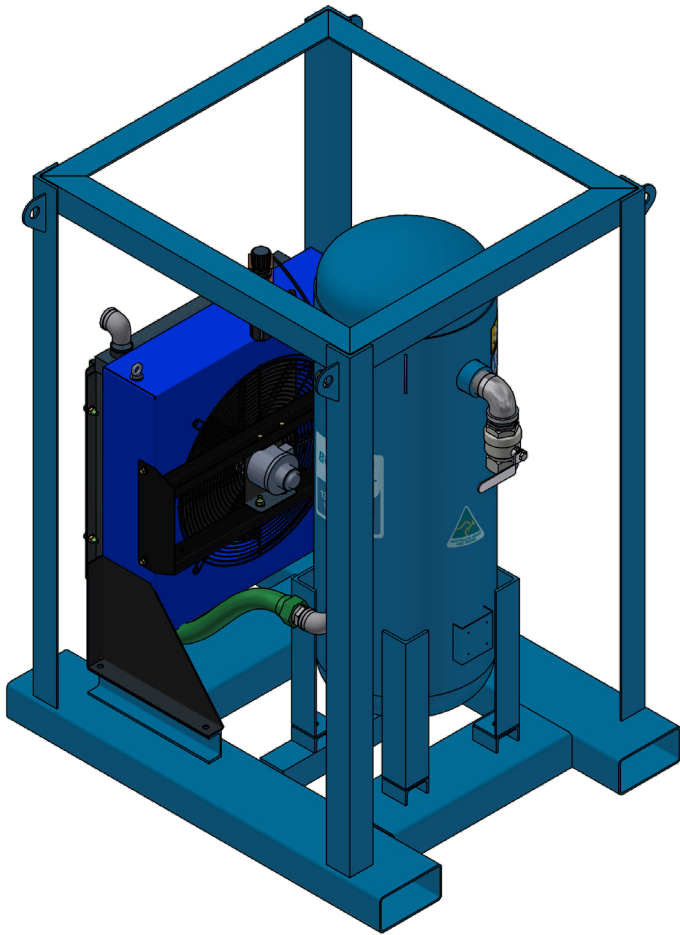

### DESICCANT-FREE

Desiccant-free design using Australian Made Coalescing Stainless Steel Filter.



### AUSTRALIAN MADE

Designed and made in Australia to AS1210 using Australian Plate Steel.



### BUILT TOUGH

Rated to 175 psi to meet all situations.



### QUIET

Designed to minimise operational sound levels.



### VERSATILE

Designed to withstand the harshest Australian climates and rugged terrains.



### PERFORMANCE

Removes up to 90% of moisture in blasting air.\*



### SITE READY

Forklift slots and lifting lugs remove the risk of unsafe manual handling.

#### Specifications

Airflow: 400cfm @ 175psi
Filtration Type: 316ss Coalescing Filter
Weight: 380kg
Length: 1200mm
Width: 900mm
Height: 1500mm
Outlet Size: 1 x 2" Ball Valve

#### Inclusions

Pressure Relief Valve with Certificate
Air Regulator
Moisture Trap
Lubricator
1 x 2" Ball Valve
MDR & Australian Design Registration Certification

#### Part Number

#### Description

1404-0400	Burwell 400 Breeze-Pro Air Dryer
-----------	----------------------------------

Best Suited to Burwell 1642 & 2449 Blast Machines

\*Conditions: Approx 35°C Ambient Temp, 100% Relative Humidity, Max Working Pressure: 200psi

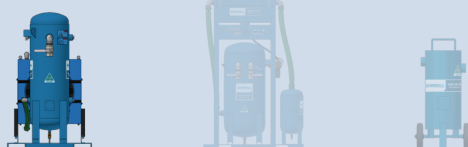
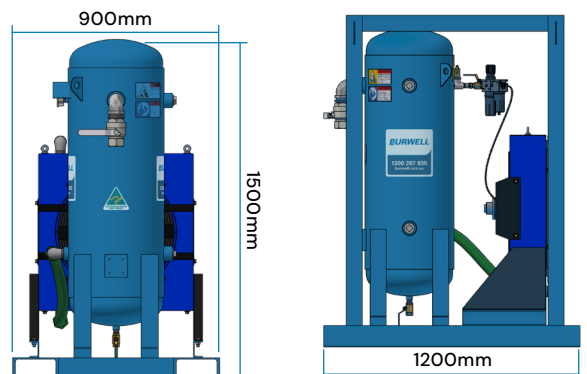

# BURWELL

1300 287 935 [burwell.com.au](http://burwell.com.au)

Version 240727