

## 506 PAT Adhesion Tester

elcometer®

en

# User Guide

## Elcometer 506

### Analogue & Digital Adhesion Tester

---

[www.elcometer.com](http://www.elcometer.com)

Copyright 2016 Burwell Technologies

elcometer®

**CONTENTS**

1	Gauge Overview	9	Digital Pressure Gauge Features & Functions
2	Box Contents	10	Dollies
3	Securing the Dolly	11	Dolly Skirts
4	Preparing the Gauge for Test	12	Adhesives
5	Attaching the Gauge to the Dolly	13	Verifying the Gauge Calibration
6	Performing the Test	14	Technical Specification
7	Assessing the Results (Destructive Testing)	15	Legal Notices & Regulatory Information
8	After Test		



For the avoidance of doubt, please refer to the original English language version.

Gauge Dimensions: Instrument Length: 290mm (11.5")

Gauge Weight: With 14.2mm & 20mm Standard Dolly Skirt: 1.8kgs (4lbs); With 50mm Standard Dolly Skirt: 2.0kgs (4.4lbs)

***The pressure gauge supplied with the Elcometer 506 Digital Adhesion Tester is intended for use only as an integral part of the instrument and should not be removed by the user and used elsewhere.***

© Elcometer Limited 2012 - 2014. All rights reserved. No part of this document may be reproduced, transmitted, transcribed, stored (in a retrieval system or otherwise) or translated into any language, in any form or by any means (electronic, mechanical, magnetic, optical, manual or otherwise) without the prior written permission of Elcometer Limited.

TMA-0564 Issue 05 - Text with cover 23792

[www.elcometer.com](http://www.elcometer.com)

elcometer®

## 1 GAUGE OVERVIEW

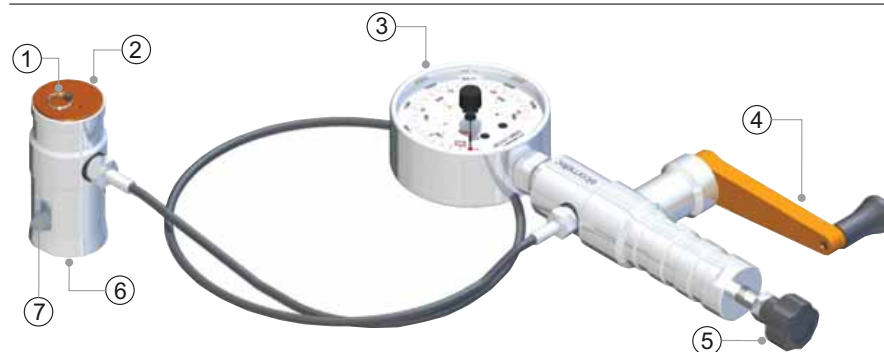

- 1 Lanyard Ring
- 2 Actuator
- 3 Pressure Gauge (Analogue or Digital)
- 4 Crank Handle
- 5 Coarse Adjustment Screw
- 6 Actuator Skirt†
- 7 Quick Connect Coupling

### Analogue Pressure Gauge

- a) Dual Scale (MPa & PSI) Dial for 20mm (outer scale) & 50mm (inner scale) Dollies

- b) Drag Max Indicator (Red)

### Digital Pressure Gauge

- c) Pressure Range Bar Graph
- d) On/Off & Enter Key
- e) Adhesion Reading
- f) Battery Life Indicator
- g) Units of Measurement (MPa or PSI)
- h) Menu & Up Key
- i) Zero/Max Hold & Down Key

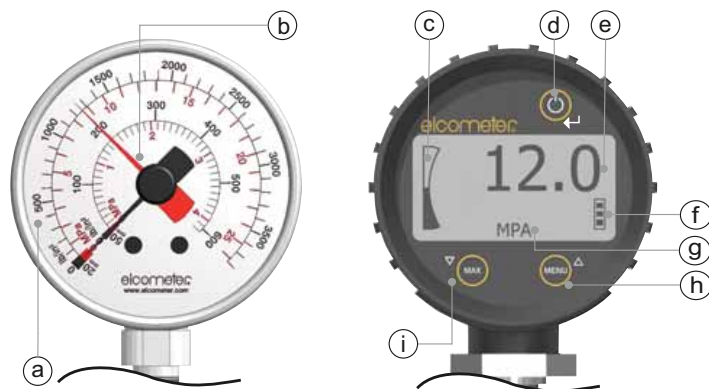

† The Standard Actuator Skirt for 20mm dollies is illustrated above. Skirts for other dolly sizes and thin substrates are also available - see Section 11 "Dolly Skirts" on page 12 for details.

elcometer®

**2 BOX CONTENTS**

UN

- Elcometer 506 Adhesion Tester
- Standard Epoxy Adhesive (2x15ml tubes)
- Abrasive Pad
- 2 x AA Batteries (digital gauge only)
- Carry Case
- Test Certificate
- User Guide

*Additional items in 20mm Kit:*

- 20mm Dollies (x10)
- 20mm Dolly Standard Skirt
- 20mm Dolly Cutter & Handle

*Additional items in 50mm Kit:*

- 50mm Dollies (x6)
- 50mm Dolly Standard Skirt
- 50mm Dolly Cutter with Drill Arbor

**3 SECURING THE DOLLY****3.1 USING 14.2mm OR 20mm DOLLIES**

- 1 Prepare the surface of the dolly and the coating where the dolly is to be applied by roughening with the abrasive pad. Then de-grease and clean both surfaces using a suitable solvent and allow to dry
- 2 Mix equal quantities of the two part Araldite adhesive and apply a thin, even layer to the prepared surface of the dolly
- 3 Press the dolly firmly onto the prepared test surface and apply pressure to squeeze out excess adhesive which should then be wiped clean
- 4 Allow the adhesive to cure - see Section 12 "Adhesives" on page 13  
*Note: If testing on vertical surfaces, you may wish to tape the dolly in place during cure.*
- 5 If required, score the coating around the dolly using the dolly cutter provided

**3**[www.elcometer.com](http://www.elcometer.com)

elcometer®

### 3 SECURING THE DOLLY (continued)

#### 3.2 TESTING ON CONCRETE USING 50mm DOLLIES

When testing on concrete using 50mm dollies, scoring of the coating down to, or into, the surface of the concrete may be required.

- 1 If testing on coatings thicker than 0.5 mm (20 mils) use the 50mm dolly cutter and arbor (mounted in a drill press or hand drill) to cut a “ring” into the concrete

*Note: Ensure that the scoring is perpendicular to the coating and that the test area is not subjected to twisting or torque. To minimise heat and suppress dust, water lubrication may be required.*

- 2 Follow steps 1-4 in Section 3.1, making sure the dolly is positioned inside the cut “ring”

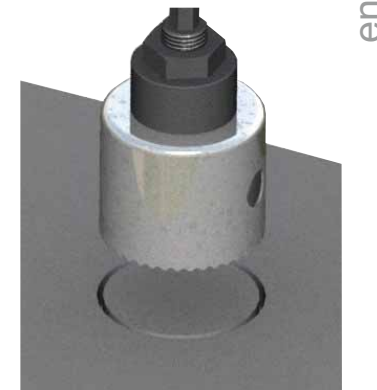

To score coatings thinner than 0.5 mm (20 mils), a sharp knife may be sufficient to carefully score around the dolly once it has been secured in place by adhesive.

### 4 PREPARING THE GAUGE FOR TEST

Fit the batteries (digital gauge only, see Section 9.1) and once the appropriate dolly skirt<sup>†</sup> is attached to the actuator:

- 1 Turn the crank handle anti-clockwise until it is fully unwound
- 2 Turn the coarse adjustment screw anti-clockwise until it is fully unwound
- 3 Ensure the quick connect coupling is fully depressed
- 4 Zero the pressure gauge, see Section 4.1 & 4.2
- 5 Select the measurement units; MPA or PSI (digital gauge only, see Section 9.3)
- 6 Select the dolly size (digital gauge only, see Section 9.4)

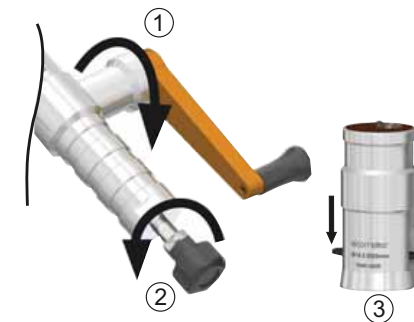

<sup>†</sup> Dolly skirts are available for different dolly diameters and for thin substrates - see Section 11 “Dolly Skirts” on page 12 for details.



elcometer®

#### 4 PREPARING THE GAUGE FOR TEST (continued)

##### 4.1 ZEROING THE ANALOGUE PRESSURE GAUGE

- 1 Fully unwind the crank handle and coarse adjustment screw (anti-clockwise) to release all pressure
- 2 Position the red drag indicator to "0" by rotating the knob on the front of the dial indicator

##### 4.2 ZEROING THE DIGITAL PRESSURE GAUGE

- 1 Press  to switch the gauge on
- 2 Fully unwind the crank handle and coarse adjustment screw (anti-clockwise) to release all pressure
- 3 Press  to zero the gauge and set the gauge to store the maximum force recorded during test, known as 'Max Hold'

Max Hold: The display holds the maximum value until the  button is pressed for a second time. 'Max Hold' should be switched on before undertaking an adhesion test, signified on the display by either <sup>MAX</sup>MPa or <sup>MAX</sup>PSI. The 'Max Hold' feature is switched off when the gauge is switched off.

*Note: "RLOCK" will be displayed if the gauge zero has failed. This is due to the pressure not being fully released from the instrument. If this occurs, release all the pressure by turning the crank handle followed by the coarse adjustment screw anti-clockwise until fully unwound and press  to repeat the gauge zero.*

#### 5 ATTACHING THE GAUGE TO THE DOLLY

- 1 Pull up the quick connect coupling, place the actuator (with skirt fitted) over the dolly then release the coupling to grip the dolly

*Note: The quick connect coupling is not a bayonet fitting. Do not attempt to push the actuator on to the dolly without lifting the quick connect coupling. If the actuator does not grip the dolly, repeat steps 1 to 3 in Section 4.*

- 2 Turn the coarse adjustment screw clockwise to apply a small amount of pressure (approximately 1 - 2MPa / 145 - 290psi), until the actuator firmly grips the dolly



5

[www.elcometer.com](http://www.elcometer.com)

elcometer®

## 5 ATTACHING THE GAUGE TO THE DOLLY (continued)

- 3 Rotate the crank handle clockwise to undertake the test - see Section 6 “Performing the Test” on page 6 for details



When testing at height or on vertical surfaces, in order to prevent damage to the surrounding coating or harm to the user, it may be necessary to use the Magnetic Anchor Clamp accessory, part number T99923797. This connects to the lanyard ring on the top of the actuator to prevent the actuator from falling when the dolly is pulled from the substrate.

## 6 PERFORMING THE TEST

### 6.1 USING 20mm OR 50mm DOLLIES - ANALOGUE PRESSURE GAUGE

- 1 Hold the gauge steady with one hand and turn the crank handle clockwise slowly and evenly to apply an increasing force to the dolly and hence stress to the coating

*Note: The rate at which the force is applied (the speed of rotation of the crank handle) should be in accordance with the relevant Standard.*

Continue until either;

- (a) the coating fails and the dolly is removed from the surface (destructive testing) or;
- (b) the minimum specified pressure value is reached (non-destructive testing)



- 2 Record the pressure indicated by the position of the red drag indicator (a), using either the 20mm or 50mm scale as appropriate and unwind the crank handle and coarse adjustment screw



Do not exceed the maximum pressure as overloading could damage the gauge.

elcometer®

## 6 PERFORMING THE TEST (continued)

### 6.2 USING 14.2mm DOLLIES - ANALOGUE PRESSURE GAUGE

Follow the procedure outlined in Section 6.1 then multiply the 20mm scale pressure reading by 2.

10MPa on 20mm Scale = 20MPa for a 14.2mm dolly

1000psi on 20mm Scale = 2000psi for a 14.2mm dolly

### 6.3 USING 14.2mm, 20mm OR 50mm DOLLIES - DIGITAL PRESSURE GAUGE

- 1 Select the measurement units; MPA or PSI, see Section 9.3
- 2 Select the dolly size, see Section 9.4
- 3 Hold the gauge steady with one hand and turn the crank handle clockwise slowly and evenly to apply an increasing force to the dolly and hence stress to the coating

*Note: The rate at which the force is applied (the speed of rotation of the crank handle) should be in accordance with the relevant Standard.*

Continue until either;

- (a) the coating fails and the dolly is removed from the surface (destructive testing) or;
  - (b) the minimum specified pressure value is reached (non-destructive testing)
- 4 Record the pressure indicated on the display (a) and unwind the crank handle and coarse adjustment screw



Do not exceed the maximum pressure as overloading could damage the gauge.

*Note: Dollies can be reused after cleaning until either the top of the dolly where it is held in position by the quick connect coupling is severely deformed or the dolly surface is no longer flat. Additional dollies are available from Elcometer or your local supplier - see Section 10 on page 12 for details.*



7

[www.elcometer.com](http://www.elcometer.com)



## 7 ASSESSING THE RESULTS (DESTRUCTIVE TESTING)

Once pulled from the surface, examine the bottom of the dolly to assess the results.

- a) *Successful Test:* In most cases the coating will fully adhere to the dolly and the test can be claimed as 100% valid.
- b) *Partial Failure:* In some cases, the coating will cover only part of the dolly face. A partial adhesion / coating failure should be recorded if the coating covers more than 50% of the dolly face.  
*Cohesive Failure:* When the coating fails in the body of the coating layer leaving some coating on the surface and some coating on the dolly face.
- c) *Adhesive Failure:* If no coating is present on the dolly this must be recorded as a failure of the adhesive (or glue). This is normally due to incorrect or insufficient mixing of the component parts of the adhesive, incompatibility of the adhesive and the coating or the dolly and / or test surface has not been properly prepared before test - see Section 3 "Securing the Dolly" on page 3

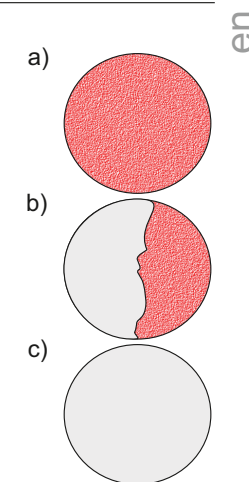

When testing coatings on concrete it is common for the adhesive bond between the coating and the concrete to exceed the strength of the concrete itself. In this case concrete will be removed from the surface and will be seen on the coating on the dolly face.

Observing the test area will give additional information about the type of failure; adhesion and cohesion between different layers of the coating.

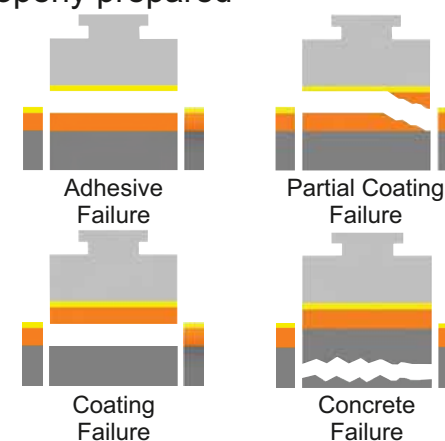



elcometer®

**8 AFTER TEST****8.1 ANALOGUE PRESSURE GAUGE**

- 1 Fully unwind the crank handle and coarse adjustment screw (anti-clockwise) to decrease the pressure to zero
- 2 Pull up the quick connect coupling to release the dolly

**8.2 DIGITAL PRESSURE GAUGE**

- 1 Fully unwind the crank handle and coarse adjustment screw (anti-clockwise) to decrease the pressure to zero
- 2 Pull up the quick connect coupling to release the dolly
- 3 Press  to release the 'Max Hold'
- 4 Press  again to zero the gauge and reset 'Max Hold'

*Note: Failure to release the 'Max Hold' and zero the gauge before each adhesion test will result in an invalid adhesion measure.*

**9 DIGITAL PRESSURE GAUGE FEATURES & FUNCTIONS**

Read this section if you are using an Elcometer 506 Adhesion Tester fitted with a digital pressure gauge.

**9.1 FITTING THE BATTERIES**

- 1 Peel the protective rubber boot forward to expose the battery compartment cover at the rear of the gauge
- 2 Rotate the battery compartment cover anti-clockwise to the 'unlock' position
- 3 Identify correct polarity and fit 2 x AA alkaline dry batteries
- 4 Replace battery compartment cover and rotate clockwise to the 'lock' position
- 5 Replace protective rubber boot taking care not to damage the front panel of the display.

The battery symbol at the bottom right hand side of the display indicates the battery condition.

**9**[www.elcometer.com](http://www.elcometer.com)

## 9 DIGITAL PRESSURE GAUGE FEATURES & FUNCTIONS (continued)





### 9.2 SWITCHING THE GAUGE ON AND OFF

TO SWITCH ON: Press . The gauge displays the version of software fitted (e.g. 1.04.03 IDENT) followed by the MIN and MAX range in MPa.

TO SWITCH OFF: Press  and hold for a second. The gauge will switch off when the button is released.





*Note: When the digital pressure gauge is switched off, "OFF" is permanently displayed.*

AUTOMATIC SWITCH OFF: The gauge has a timer function and can be set to switch off automatically after 1, 5 or 20 minutes of inactivity. The gauge default setting is NONE.

- 1 Press  until TIMER is displayed followed by  to select
- 2 Press  or  to toggle between the options; NONE, 1 MIN, 5 MIN, 20 MIN
- 3 Press  to select the setting required





### 9.3 SELECTING THE UNITS

The gauge can display readings in MPa (Megapascals) or PSI (Pounds per Square Inch)

- 1 Press  until UNITS is displayed followed by  to select
- 2 Press  or  to toggle between MPA and PSI
- 3 Press  to select the units required







elcometer®

**9 DIGITAL PRESSURE GAUGE FEATURES & FUNCTIONS (continued)****9.4 SETTING THE DOLLY SIZE**

- 1 Press  until DOLLY is displayed followed by  to select
- 2 Press  or  to toggle between the options; 20MM, 14.2MM, 50MM
- 3 Press  to select the setting required

**9.5 RESETTING THE GAUGE**

The gauge has a gauge reset function which restores the original factory settings.

- 1 Press  until RESET is displayed followed by  to select
- 2 Press  again to confirm the reset. The gauge will reset and switch off
- 3 To cancel the reset request, press  or  to toggle to 'CANCL' followed by  to confirm

elcometer®

506

## 10 DOLLIES

The Elcometer 506 is available as a 20mm or 50mm dolly kit. 14.2mm dollies are available to purchase as an optional accessory.

14.2mm: ideal for testing on small surface areas, for measurements over 25MPa (3600psi) and suitable for use on some curved surfaces.

20mm: suitable for use on a variety of coatings / substrates.

50mm: Coatings on concrete, cementitious layers and uneven surfaces can be tested more effectively with the larger 50mm dolly.

### Description

Aluminium Dolly 14.2mm (x10)

Aluminium Dolly 14.2mm (x100)

Aluminium Dolly 20mm (x10)

Aluminium Dolly 20mm (x100)

Aluminium Dolly 50mm (x4)

### Sales Part Number

T9990014AL-10

T9990014AL-100

T9990020AL-10

T9990020AL-100

T9990050AL-4

## 11 DOLLY SKIRTS

Standard skirts are available for 14.2mm and 20mm dollies as well as 50mm dollies. Special skirts are also available for testing on thin substrate to even out the load, as using a standard skirt on a thin substrate may cause the substrate to bend or flex during test.

### Description

Standard Skirt for 14.2mm & 20mm Dollies

Thin Substrate Skirt for 14.2mm Dollies

Thin Substrate Skirt for 20mm Dollies

Standard Skirt for 50mm Dollies

### Sales Part Number

T9991420S

T9990014T

T9990020T

T9990050S

[www.elcometer.com](http://www.elcometer.com)

12

elcometer®

**12 ADHESIVES**

 The adhesive supplied with the Elcometer 506 is Araldite® Standard, a two-pack epoxy paste which is mixed from approximately equal volumes of the two components. Measurement by eye is sufficient. When mixed it should be used within one hour. Curing Times: 24 hours at 25°C (77°F); 3 hours at 60°C (140°F)

Araldite® is suitable for warm and hot environments. Lower temperatures can require extended curing times of up to 3 days or more. The expiry date of the adhesive should be checked before use. Adhesive which has expired should not be used.

Unused adhesive must be disposed of as special waste unless it has been fully cured. To dispose of excess adhesive at the end of its shelf life simply mix the remaining material and allow it to cure before disposal.

**Description**

Araldite® Standard Two Part Epoxy Adhesive; 2x15ml Tubes

**Sales Part Number**

T99912906

A Material Safety Data Sheet for adhesive supplied by Elcometer can be downloaded via our website:  
Araldite® Standard Two Part Epoxy Adhesive: [www.elcometer.com/images/MSDS/araldite\\_epoxy\\_adhesive.pdf](http://www.elcometer.com/images/MSDS/araldite_epoxy_adhesive.pdf)

*Note: Other suitable adhesives include Loctite® Hysol® 907 and 3M™ Scotch-Weld™ Epoxy Adhesive.*

*The suitability of any adhesive should be determined by the user. Some coatings can be adversely affected by adhesives. Some adhesives can be contaminated by coating environments, solvents etc.*

### 13 VERIFYING THE GAUGE CALIBRATION

The calibration of the gauge can be verified in the field using the Elcometer Adhesion Verification Unit (AVU), part number T99923924, which connects to the gauge. The pressure reading on the Elcometer 506 indicator is compared with the reading of the gauge pressure on the AVU to verify the calibration. For further information contact Elcometer or visit [www.elcometer.com](http://www.elcometer.com)



### 14 TECHNICAL SPECIFICATION

Dolly Diameter	14.2mm	20mm	50mm
Scale Range	0 - 52MPa (0 - 7600psi)	0 - 26MPa (0 - 3800psi)	0 - 4.2MPa (0 - 610psi)
Operating Range (Certified)	Analogue: 6 - 46MPa (880 - 6680psi)	Analogue: 3 - 23MPa (440 - 3340psi)	Analogue: 0.5 - 3.7MPa (70 - 535psi)
	Digital: 4 - 50MPa (580 - 7260psi)	Digital: 2 - 25MPa (290 - 3630psi)	Digital: 0.3 - 4MPa (45 - 580psi)
Scale Resolution	Analogue: 0.1MPa (10psi)	Analogue: 0.1MPa (10psi)	Analogue: 0.05MPa (5psi)
	Digital: 0.01MPa (1psi)	Digital: 0.01MPa (1psi)	Digital: 0.01MPa (1psi)
Accuracy	±1% of full scale		
Power Supply (Digital Gauge only)	2 x AA alkaline dry batteries (rechargeable batteries can be used)		

elcometer®

**14 TECHNICAL SPECIFICATION (continued)**

en

<b>Dolly Diameter</b>	<b>14.2mm</b>	<b>20mm</b>	<b>50mm</b>
<b>Instrument Weight</b>	1.8kg (4lb)	1.8kg (4lb)	2.0kg (4.4lb)
<b>Kit Weight</b>	n/a	4kg (8.8lb)	5.2kg (11.5lb)
<b>Instrument Length</b>	290mm (11.5")	290mm (11.5")	290mm (11.5")
<b>Actuator Height</b>	85mm (3.4") (14.2mm skirt fitted)	85mm (3.4") (20mm skirt fitted)	110mm (4.3") (50mm skirt fitted)

Can be used in accordance with:

AS/NZS 1580.408.5, ASTM D4541, ASTM D7234, BS 1881-207, DIN 1048, EN 12636, EN 13144, EN 1542, ISO 16276-1, ISO 4624, NF T30-606

*Note: The Elcometer 506 Adhesion Tester is a Type IV adhesion tester as defined by ASTM D4541.*

**15 LEGAL NOTICES & REGULATORY INFORMATION**

The Elcometer 506 Digital Adhesion Tester meets the Electromagnetic Compatibility Directive. The product is Class B, Group 1 ISM equipment according to CISPR 11. Group 1 ISM product: A product in which there is intentionally generated and/or used conductively coupled radio-frequency energy which is necessary for the internal functioning of the equipment itself. Class B product are suitable for use in domestic establishments and in establishments directly connected to a low voltage power supply network which supplies buildings used for domestic purposes.

elcometer® is a registered trademark of Elcometer Limited, Edge Lane, Manchester, M43 6BU. United Kingdom

All other trademarks acknowledged.



**elcometer®**  
www.elcometer.com

**ENGLAND**

Elcometer Limited  
Edge Lane  
Manchester M43 6BU  
Tel: +44 (0)161 371 6000  
Fax: +44 (0)161 371 6010  
e-mail: sales@elcometer.com  
www.elcometer.com

**USA**

Elcometer Inc  
1893 Rochester Industrial Drive  
Rochester Hills Michigan 48309  
Tel: +1 248 650 0500  
Toll Free: 800 521 0635  
Fax: +1 248 650 0501  
e-mail: inc@elcometer.com  
www.elcometer.com

**ASIA & THE FAR EAST**

Elcometer (Asia) Pte Ltd  
896 Dunearn Rd  
Sime Darby Centre #03-09  
Singapore 589472,  
Tel: +65 6462 2822  
Fax: +65 6462 2860  
e-mail: asia@elcometer.com  
www.elcometer.com

**JAPAN**

Elcometer KK  
7F Toranomon MT40 Bldg. 5-13-1  
Toranomon, Minato-ku  
Tokyo 105-0001  
Tel: +81 (0)3-4530-9714  
Fax: +81 (0)3-4530-9713  
email: jp\_info@elcometer.com  
www.elcometer.co.jp

**BELGIUM**

Elcometer SA  
Rue Vallée 13  
B-4681 Hermalle /s Argenteau  
Tel: +32 (0)4 379 96 10  
Fax: +32 (0)4 374 06 03  
e-mail: be\_info@elcometer.com  
www.elcometer.be

**FRANCE**

Elcometer Sarl  
97 Route de Chécy  
45430 BOU  
Tel: +33 (0)2 38 86 33 44  
Fax: +33 (0)2 38 91 37 66  
e-mail: fr\_info@elcometer.com  
www.elcometer.fr

**GERMANY**

Elcometer Instruments GmbH  
Ulmer Strasse 68  
D-73431 Aalen  
Tel: +49(0)7361 52806 0  
Fax: +49(0)7361 52806 77  
e-mail: de\_info@elcometer.de  
www.elcometer.de

**THE NETHERLANDS**

Elcometer NL  
Newtonlaan 115  
3584 BH Utrecht  
Tel: +31 (0)30 210.7005  
Fax: +31 (0)30 210.6666  
email: nl\_info@elcometer.com  
www.elcometer.com