



CLEMCO
The Performance
System

TECHNICAL DATA SHEET

Note: For safety, efficiency, and productivity, read and follow the owner's manual and seek training for everyone who will use this equipment.

Purpose

The CMS-3 monitor detects carbon monoxide in the breathing-air supply and triggers audible, visual, and vibratory alarms when CO is detected in concentrations of at least 10 parts per million. The alarms alert the operator to an unsafe condition.

Requirements for Operation

- Battery installed in the CMS-3
- 25 ppm calibration gas, calibration cup and connector
- Grade D or ambient-air breathing-air supply for the abrasive blast operator
- Thorough familiarity with the CMS-3 instructions

Description of Operation

OSHA requires Grade D quality breathing air and NIOSH-approved Type CE continuous-flow supplied-air respirators for abrasive blast operators. OSHA regulations call for a maximum exposure limit to carbon monoxide of 10 parts per million (ppm). When the presence of carbon monoxide is detected at this level, the CMS-3 emits an audible alarm, a visible flash, and the unit vibrates. When an alarm occurs, the user should remove the respirator immediately when it is safe to do so. To prolong battery life, turn unit off when not in use; turn unit on and re-install at beginning of work shift.

CMS-3 Features

- Digital liquid crystal display (LCD)
- Audible, visual, and vibrating alarms
- Low battery alarm
- Sensor fail alarm
- Replaceable sensor and battery

Description

The CMS-3 carbon monoxide (CO) monitor mounts inside the blast respirator to immediately warn the blast operator when deadly CO is detected in the breathing air

Note: CMS monitors do not remove CO or convert CO to carbon dioxide (CO₂).

CMS Series Carbon Monoxide Monitor - Alarm

**Model CMS-3 In-Helmet
Monitor with Calibration Kit
Stock No. 24612**

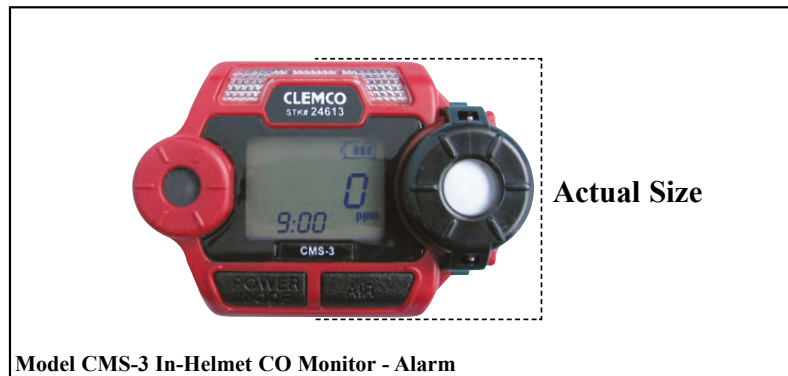

Actual Size

Model CMS-3 In-Helmet CO Monitor - Alarm

Advantages

- Blast operator can work independently. No need to rely upon others to warn operator or take action when monitor alarms. No need for remote alarm; each user is individually protected for instant awareness of a hazardous condition.
- Unit is small, lightweight, and conveniently worn inside blast respirator. Requires no external connections or hoses.
- Unit can be calibrated in minutes, is easily installed, and easily removed.
- Long-life, economical easy-to-replace sensor with estimated sensor life of 2 years.
- Unit uses a small commonly-available easy-to-replace lithium battery.
- Microprocessor controlled with digital read-out for accurate readings.

Approvals and Certifications

Meets OSHA requirement for CO monitoring.

NIOSH-approved as an extension of the respirator approval for Clemco Apollo 20, 60, and 600 respirators.

Safety Rating: CSA classified "C/US" as intrinsically safe. Class I, Division I, Groups A, B, C, and D, Temp. code T4.

Specifications

OSHA rules dictate that maximum exposure limit to CO for abrasive blasters breathing Grade D air is 10 parts per million.

- Sampling by diffusion
- Operating temperature and humidity range: -4 to 104 degrees F (-20 to 40 degrees C); up to 85 percent relative humidity (non-condensing)
- Alarm points: Low and high alarms factory set at 10 ppm
- Accuracy rating: plus or minus 2 ppm
- Powered by 3-volt coin-type lithium battery (CR2450)
- Unit net weight 1.6 ounces (0.1 lb)
- Dimensions: 2.5" w x 1.7" h x 0.9" d
- Unit calibrated with 25 ppm test gas; optional impurity-free gas available for fresh-air setting
- Over-range condition indicated by audible, vibratory, and visual alarms
- Low-battery warning given by visual flashing indicator
- Dead battery indicated by audible alarm
- System failure warning given by audible alarm
- Attachment to respirator: VELCRO®
- Warranty: 1 year material and workmanship

CMS-3 System and Accessories

Item Description	Stock No.
(-) CMS-3 CO monitor package Includes items with asterisk (*)	24612
1. *CMS-3 CO monitor only	24613
2. *Calibration connector assembly Includes calibration connector, tubing and cup	24614
3. Test gas, *25 ppm CO	25573
Impurity free	11132
4. Calibration cup	24615

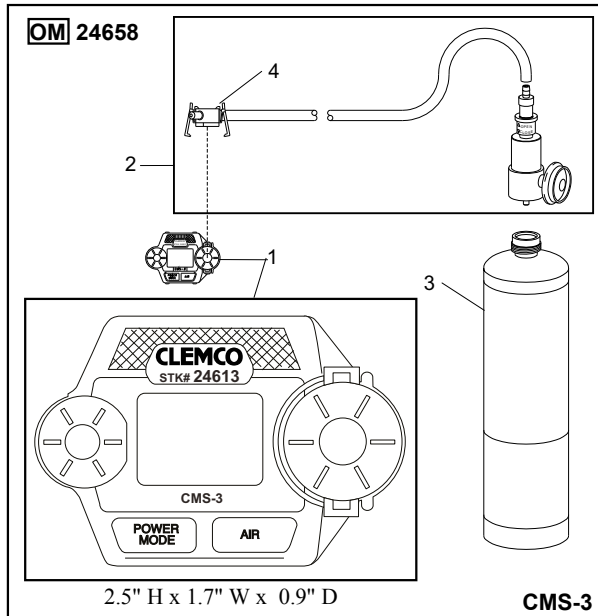

Packaging: Monitor enclosed in plastic 3" diameter x 5" jar

Stock No.	Carton Dimensions	Shipping Wt.
24612	10"W x 12"L x 8-3/4" H	4 lb
24613	6-3/4"W x 11-1/4"L x 3-1/2" H	1 lb

Color: CMS-3: Red and black

Other Available Clemco CO Alarms

Description	Stock No.
CMS-1 Wall-mountable with calibration kit	23017
CMS-2 Field-portable with calibration kit	22894

Related Clemco Literature

Description	Stock No.
CMS-3 Owner's Manual	24658



ISO 9001:2008 certified. Clemco is committed to continuous product improvement. Specifications are subject to change without notice.

© 2014 Clemco Industries Corp. • One Cable Car Drive • Washington, MO 63090 • Phone (636) 239-4300 • Fax (800) 726-7559
Stock No. 25580 www.clemcoindustries.com 0611, Rev. B 01/14

CMS-3 Replacement Parts

Item Description	Stock No.
1. Sensor.....	24616
2. Service kit, includes Items 3, 4 and 5.....	24617
3. Kit, screws, seals, and strips	25577
3a. Cap, sensor	
3b. Gasket, sensor	
3c. Screw set	
3d. O-ring, battery cover	
3e. VELCRO® tape, loop side, 1" x 1-1/4"	
3f. VELCRO® tape, hook side, 1" x 2"	
4. Discs, sensor cover, pack of 10.....	25563
5. Filter, charcoal, pack of 5	25564
6. Mounting plate.....	25575
7. Battery, Lithium, 3-volt, coin-type, model CR2450	24619

VELCRO® refers to VELCRO® brand hook and loop fastener.
VELCRO® is a registered trademark of VELCRO Industries B.V.

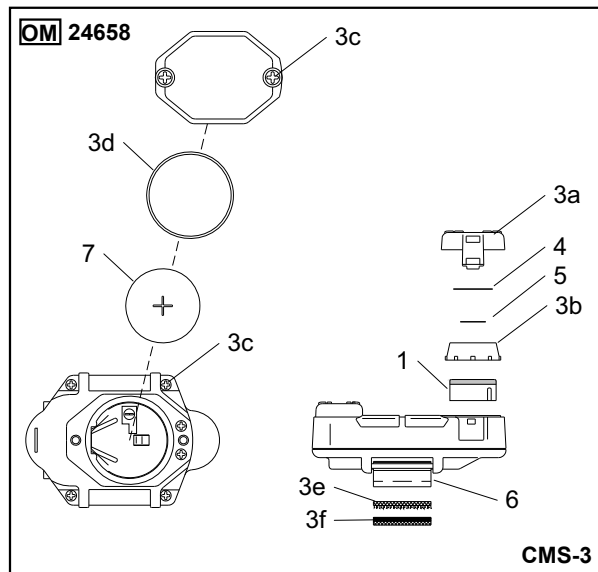

Authorized Distributor: