

EcoQuip 2™ EQp Vapor Abrasive Blast System

3A4802K

EN

***Vapor abrasive blast system for coating removal and surface preparation.
For professional use only.***

Maximum Working Pressure: 150 psi (1.03 MPa, 10.3 bar)

See page 3 for model information and approvals.



Important Safety Instructions

Read all warnings and instructions in this and all related manuals. Save these instructions.

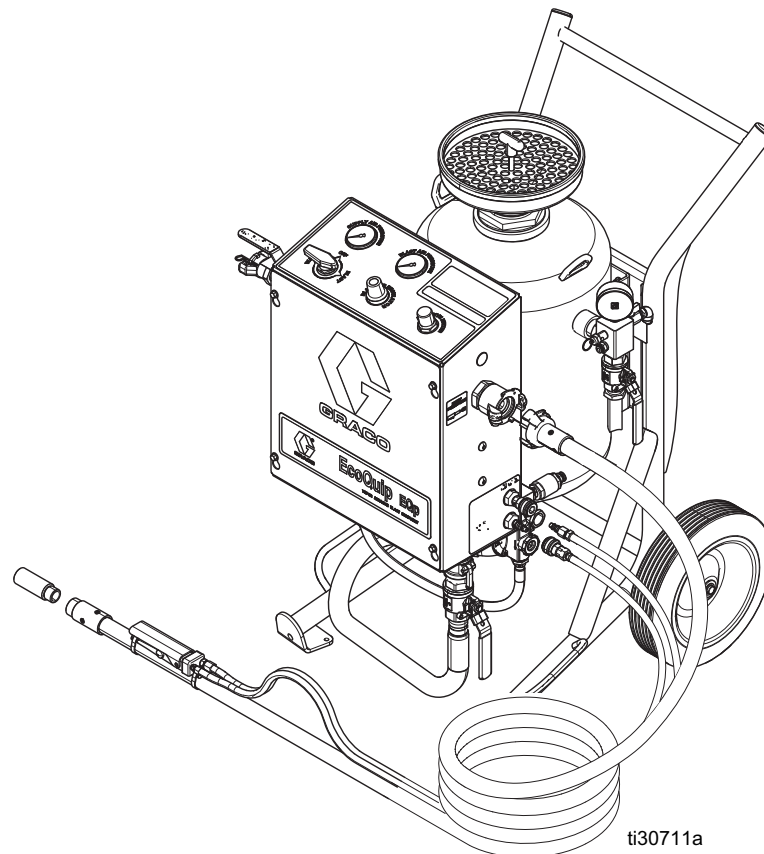









CE **Ex** II 2G Ex h T3 Gb X

Contents

Models	3	Troubleshooting	25
Related Manuals	3	Repair	31
Warnings	4	Replace the Pinch Hose	31
Component Identification	7	Install the Pinch Hose	31
Pressure Relief Procedure	8	Debris in Media Path	32
Grounding	8	Parts	34
Operation	9	EQp	34
Lift the System	9	Enclosure	37
Blast on Higher Surfaces	9	Blast Hoses	42
Connect the Water Supply	10	Kits and Accessories	43
Inspect Pinch Hose	11	Blast Hoses with Control Hose	43
Connect the Blast Hose and Air Hose	11	Blast Hoses without Control Hose	43
Set Up the Equipment	13	Blast Control Hoses	43
Set the Abrasive Metering Valve	15	Nozzles	43
General Application Guides	16	Spare Parts	44
Use the Wash Feature	18	Accessories	45
Use Rust Inhibitor	18	Tubing Schematic	46
Refill the Pot with Abrasive	19	Tubing Schematic Key	47
Standby	19	Dimensions	48
Shutdown	20	Technical Specifications	49
Drain the Pot	20	California Proposition 65	49
Winterize the Equipment	24	Graco Standard Warranty	50

Models









EcoQuip 2 Vapor Blast Systems		
Part	Description	Approvals
278860	EcoQuip 2 EQp Bare System	   II 2G Ex h T3 Gb X
278861	EcoQuip 2 EQp System, 0.5 in. Blast Hose, #5 Nozzle	   II 2G Ex h T3 Gb X
278862	EcoQuip 2 EQp System, 1 in. Blast Hose, #6 Nozzle	   II 2G Ex h T3 Gb X

Related Manuals

Manual in English	Description
309474	Water Pressure Regulator
3A5403	Water Tank Kit
3A5023	Stainless Steel 15:1 Pump

Warnings

The following warnings are for the setup, use, grounding, maintenance, and repair of this equipment. The exclamation point symbol alerts you to a general warning and the hazard symbols refer to procedure-specific risks. When these symbols appear in the body of this manual or on warning labels, refer back to these Warnings. Product-specific hazard symbols and warnings not covered in this section may appear throughout the body of this manual where applicable.

 <h1 style="margin: 0;">WARNING</h1>	
 	<p>SPECIAL CONDITIONS FOR SAFE USE</p> <ul style="list-style-type: none"> • Ground all equipment in the work area. See Grounding.
  	<p>DUST AND DEBRIS HAZARD</p> <p>Use of this equipment can result in the release of potentially harmful dust or toxic substances from the abrasive being used, the coatings being removed, and the base object being blasted.</p> <ul style="list-style-type: none"> • For use only by sophisticated users familiar with applicable governmental safety and industrial hygiene regulations. • Use equipment only in a well-ventilated area. • Wear a properly fit-tested and government approved respirator suitable for the dust conditions. • Follow local ordinances and/or regulations for disposal of toxic substances and debris.
 	<p>PRESSURIZED EQUIPMENT HAZARD</p> <p>Fluid from the equipment, leaks, or ruptured components can splash in the eyes or on skin and cause serious injury.</p> <ul style="list-style-type: none"> • Follow the Pressure Relief Procedure when you stop spraying/dispensing and before cleaning, checking, or servicing equipment. • Tighten all fluid connections before operating the equipment. • Check hoses, tubes, and couplings daily. Replace worn or damaged parts immediately.



WARNING



EQUIPMENT MISUSE HAZARD

Misuse can cause death or serious injury.

- Do not operate the unit when fatigued or under the influence of drugs or alcohol.
- Do not exceed the maximum working pressure or temperature rating of the lowest rated system component. See **Technical Specifications** in all equipment manuals.
- Do not use this equipment without hose restraints and coupler pins installed on all air and blast hose couplings.
- Do not blast unstable objects. The high amount of fluid flow from the nozzle can potentially move heavy objects.
- Do not exceed load rating of lift eyes.
- Do not operate equipment on or stand on an unstable support. Keep effective footing and balance at all times.
- Use fluids and solvents that are compatible with equipment wetted parts. See **Technical Specifications** in all equipment manuals. Read fluid and solvent manufacturer's warnings. For complete information about your material, request Safety Data Sheets (SDSs) from distributor or retailer.
- Never use 1, 1, 1-trichloroethane, methylene chloride, other halogenated hydrocarbon solvents or fluids containing such solvents in pressurized aluminum equipment. Such use could result in a chemical reaction, with the possibility of explosion.
- Do not leave the work area while equipment is energized or under pressure.
- Turn off all equipment and follow the **Pressure Relief Procedure** when equipment is not in use.
- Check equipment daily. Repair or replace worn or damaged parts immediately with genuine manufacturer's replacement parts only.
- Do not alter or modify equipment. Alterations or modifications may void agency approvals and create safety hazards.
- Make sure all equipment is rated and approved for the environment in which you are using it.
- Use equipment only for its intended purpose. Call your distributor for information.
- Route hoses and cables away from traffic areas, sharp edges, moving parts, and hot surfaces.
- Do not kink or over bend hoses or use hoses to pull equipment.
- Keep children and animals away from work area.
- Comply with all applicable safety regulations.







BURN HAZARD

Equipment surfaces and fluid that is heated can become very hot during operation. To avoid severe burns.

- Do not touch hot fluid or equipment.

WARNING

	<p>FIRE AND EXPLOSION HAZARD</p> <p>Flammable fumes, such as solvent, in work area can ignite or explode. To help prevent fire and explosion:</p> <ul style="list-style-type: none"> • Use equipment only in well ventilated area. • Abrasive material exiting blast nozzle can generate sparks. When flammable liquids are used near the blast nozzle or for flushing or cleaning, keep the blast nozzle at least 20 feet (6 meters) away from explosive vapors. • Ground all equipment in the work area. See Grounding instructions. • Keep work area free of debris, including solvent, rags and gasoline. • Keep a working fire extinguisher in the work area.
	<p>MOVING PARTS HAZARD</p> <p>Moving parts can pinch, cut or amputate fingers and other body parts.</p> <ul style="list-style-type: none"> • Keep clear of moving parts. • Do not operate equipment with protective guards or covers removed. • Pressurized equipment can start without warning. Before checking, moving, or servicing equipment, follow the Pressure Relief Procedure and disconnect all power sources.
	<p>PERSONAL PROTECTIVE EQUIPMENT</p> <p>Wear appropriate protective equipment when in the work area to help prevent serious injury, including eye injury, hearing loss, inhalation of toxic fumes, and burns. Protective equipment includes but is not limited to:</p> <ul style="list-style-type: none"> • Protective eyewear, and hearing protection. • Protective clothing, shoes, and gloves. • Properly fit-tested and government approved respirator suitable for the dust conditions.
	<p>RECOIL HAZARD</p> <p>Blast nozzle may recoil when triggered. If you are not standing securely, you could fall and be seriously injured.</p>

Component Identification

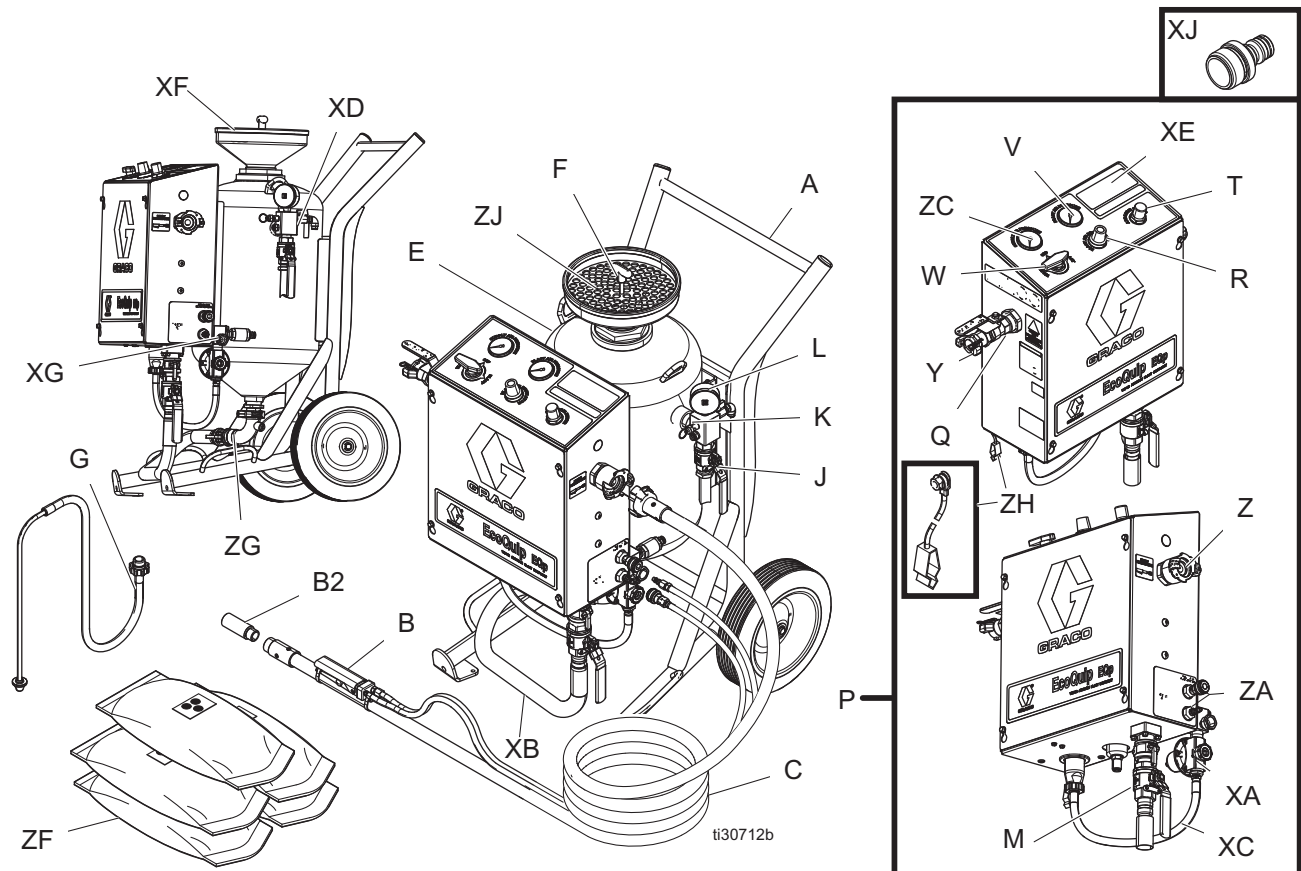

Ref.	Description
A	Frame
B	Blast Control Switch
B2	Blast Nozzle
C	Blast Hose
E	Pot
F	Pop-up Handle
G	Siphon Hose
J	Pot Dump Valve
K	Pressure Relief Valve
L	Pot Pressure Gauge
M	Abrasive Ball Valve
P	Control Box
Q	Air Supply Valve
R	Blast Pressure Regulator
T	Abrasive Metering Valve
V	Blast Pressure Gauge
W	Selector Valve

Ref.	Description
Y	Air Supply Connection
Z	Blast Hose Connection
ZA	Pneumatic Control Connection
ZC	Supply Pressure Gauge
ZF	Abrasive Material
ZG	Pot Outlet Manifold
ZH	Ground Wire and clamp
ZJ	Pop-up Seal
XA	Water Inlet Pressure Regulator
XB	Abrasive Hose
XC	Pump Inlet Hose
XD	Fill/Flush Valve
XE	Quick Start Guide
XF	Pot Funnel
XG	Garden Hose Connection
XJ	Garden Hose to Garden Adapter

Pressure Relief Procedure



Follow the Pressure Relief Procedure whenever you see this symbol.

<p>This equipment stays pressurized until pressure is manually relieved. To help prevent serious injury from pressurized fluid, such as splashing fluid, follow the Pressure Relief Procedure when instructed.</p>				

1. Close the abrasive ball valve (M).

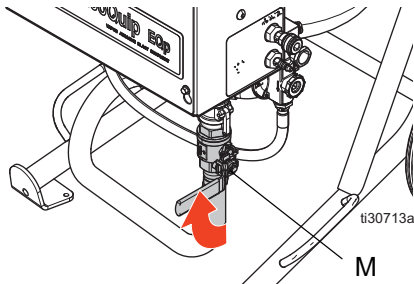

2. Close the compressor supply air valve, then turn the compressor off.
3. Make sure the supply pressure gauge (ZC) reads 0, then close the air supply valve (Q).

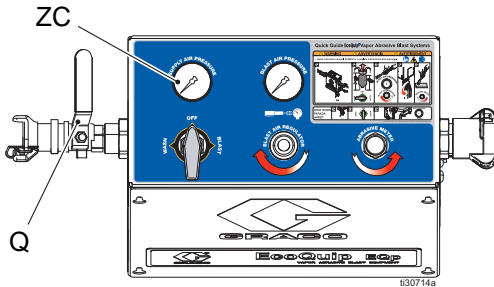

4. Disconnect the air supply hose.
5. Turn the selector valve (W) to BLAST.

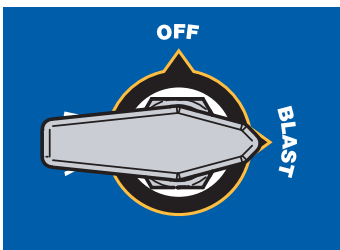

6. Close the fill/flush valve (XD) and disconnect the pressurized water supply.

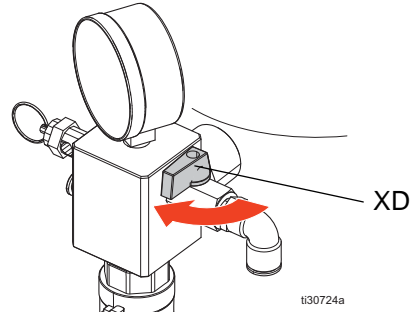

7. Open the pot dump valve (J) until the pot pressure gauge (L) reads 0 psi.

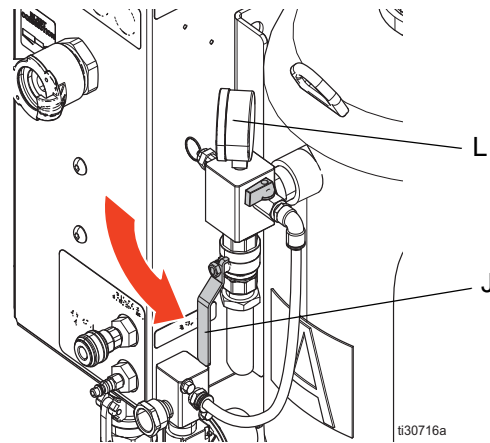

Grounding

<p>The equipment must be grounded to reduce the risk of static sparking. Static sparking can cause fumes to ignite or explode. Grounding provides an escape wire for the electric current.</p>				

Systems: Use the supplied ground wire and clamp (237686).

Air and fluid hoses: Use only genuine Graco blast hoses with a maximum of 150 ft (45 m) combined blast hose length to ensure grounding continuity. Check the electrical resistance of the blast hoses. If the total resistance to ground exceeds 29 megaohms, replace the blast hose immediately.

Air compressor: Follow the manufacturer's recommendations.

Operation

Lift the System

- Lift the system with a lift apparatus rated appropriately for the weight of the system (see **Technical Specifications**, page 49).
- Do not lift the system by the handle.
- Use the lift eyes shown below to lift the system.

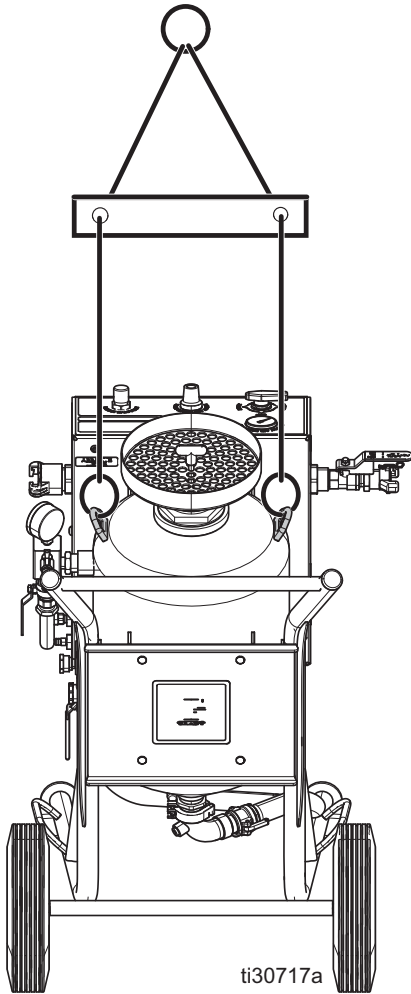

Blast on Higher Surfaces

NOTICE

When blasting on a surface higher than the equipment, make sure that there is a length of blast hose on the ground equal to 10-20% of the height. The hose on the ground prevents unspent abrasive in the hose from backing up into the internal plumbing of the control box, which can cause damage to the main air regulator when the blast switch is disengaged.

For example: When blasting 50 ft (15 m) straight up, use at least 10 ft (3 m) of blast hose on the ground before the blast hose goes up to the blasting height.

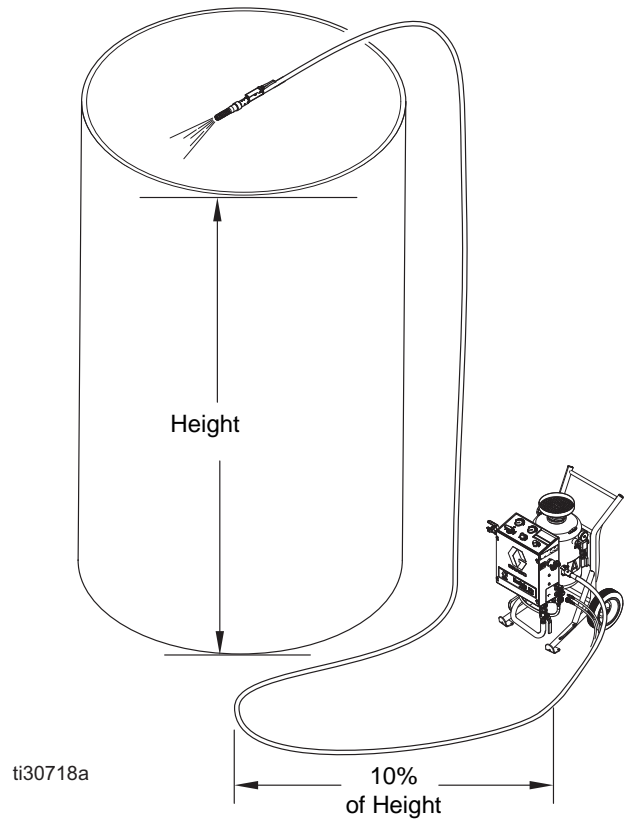

Connect the Water Supply



NOTICE

Pump runaway can damage pump seals. If the pump begins to run too fast, shut it down to avoid damage.

Pressurized Water Supply

1. Close the fill/flush valve (XD).

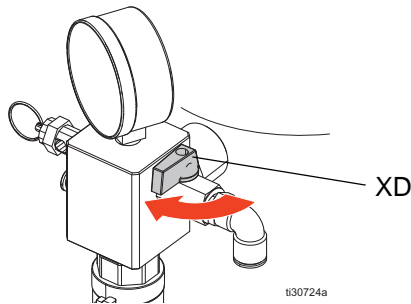

2. Connect to a pressurized water supply hose with a minimum ID of 3/4 in. (19 mm) to the garden hose connection (XG).

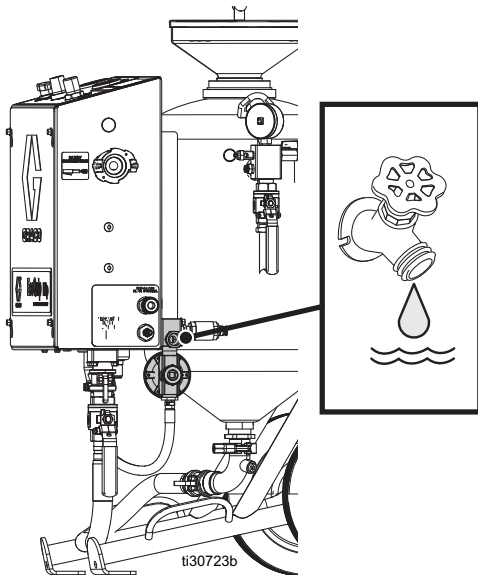

NOTE: The maximum water supply pressure is 100 psi (6.8 bar, 0.68 MPa). The minimum flow requirements is 1 gpm (3.8 lpm).

3. Turn on water supply.

Non-Pressurized Water Supply

NOTE: The fill/flush valve will not operate with a non-pressurized water supply.

NOTE: To prime the pump, turn the selector valve to BLAST.

Use a Siphon Hose

1. Close the fill/flush valve (XD).
2. Disconnect the pump inlet hose at the pump inlet.

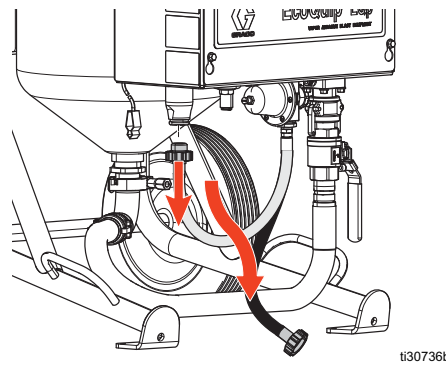

3. Connect the included siphon hose to the pump inlet to draw from a 5 gallon bucket or an open container.

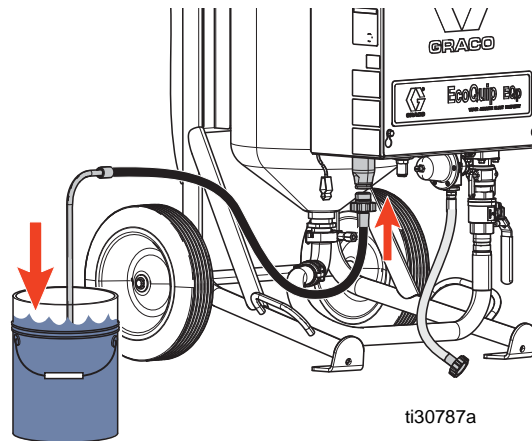

Use the Water Tank Kit

1. Disconnect the pump inlet hose at the pump inlet.
2. Connect the pump inlet adapter fitting included in the water tank kit (see Kits and Accessories on page 42) to the pump inlet and follow the kit instructions.

Inspect Pinch Hose

Inspect the pinch hose monthly or at the start of each job. Look for “bubbles” in the outer casing. If bubbles in the casing are found, replace the pinch hose (see **Replace the Pinch Hose**, page 31). In case of pinch hose failure, have a spare hose (see **Blast Hoses**, page 42) on hand.

NOTE: Three main factors affect the life of the pinch hose: the use of abrasive media (coarse/sharp), high blast control switch trigger rate, and high air inlet pressure to the system. If your setup reflects one or more of these factors, inspect the pinch hose at the start of a job and weekly thereafter for signs of failure, indicated by bubbling.

Connect the Blast Hose and Air Hose

1. Connect the grounding cable clamp to a true earth ground.

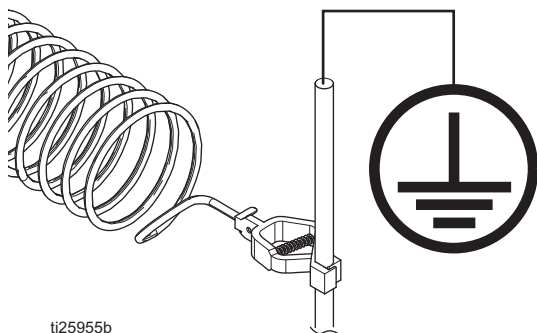

2. Always purge the air supply hose before connecting the air supply hose from the compressor (or an on-site compressed air source) to the panel. Make sure all debris is cleared from the hose.

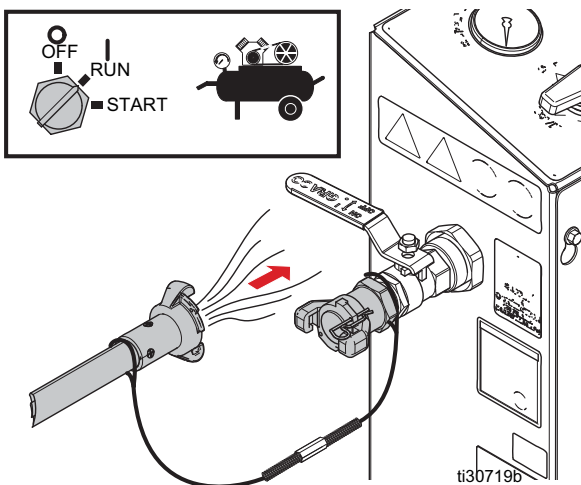

3. Connect an appropriately sized air supply hose to the air inlet and install the hose restraints and coupler pins (see **Technical Specifications**, page 49).

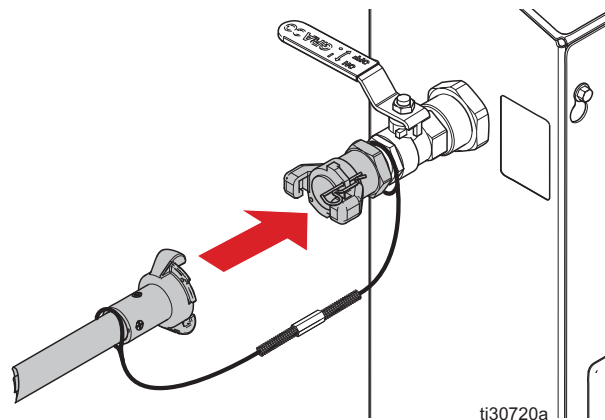

NOTICE

Damage to the tubing connections on the blast control can occur if the blast circuit is allowed to rotate. To avoid damage, use a wrench to hold the blast circuit inside the enclosure while installing threaded fittings to the blast circuit connections.

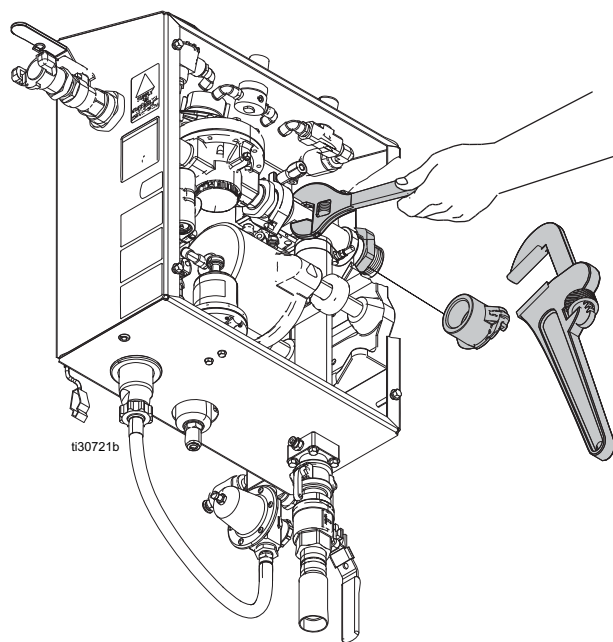

4. Open the compressor air supply valve (150 psi, 10.3 Bar, 1.03 MPa) maximum.

NOTE: Make sure the air supply meets the appropriate air flow requirements (see **Technical Specifications**, page 49).

Operation

5. Connect the blast hose, hose restraints, control hoses, and coupler pins.

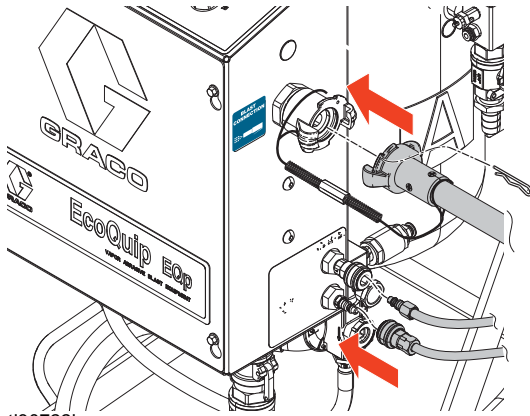

ti30722b

NOTICE

Do not use a wrench when installing the nozzle. Damage to the seal could occur. To avoid seal damage, always hand-tighten the nozzle.

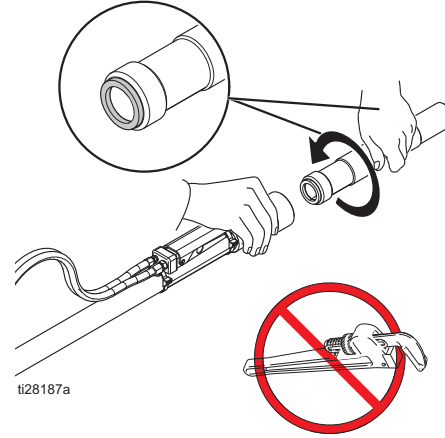

ti28187a

Set Up the Equipment



1. Connect to a water supply.

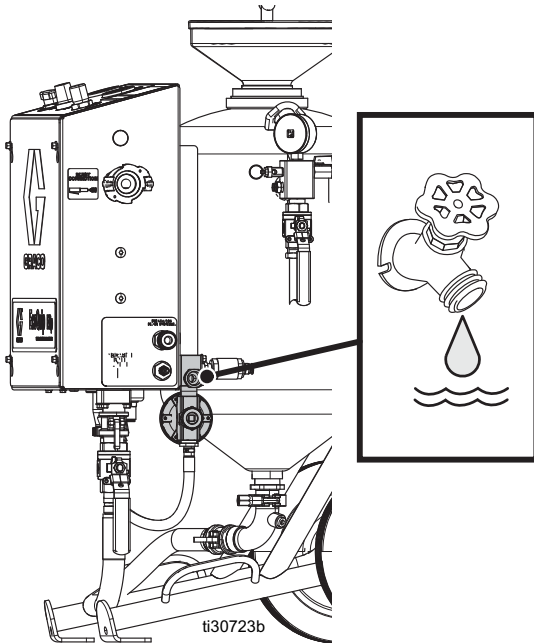

2. Close the abrasive ball valve (M).

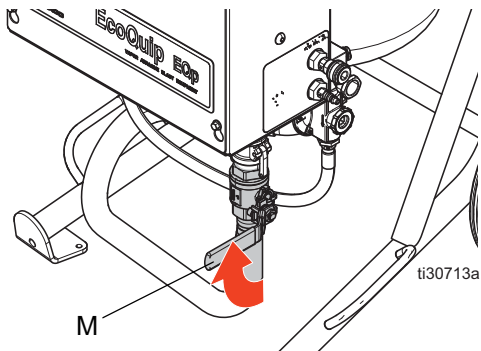

3. Turn the selector valve to OFF.

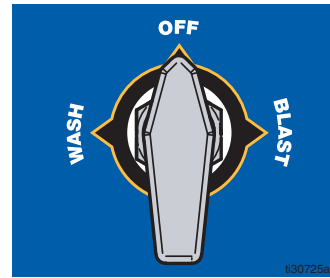

4. Open the air supply valve (Q).

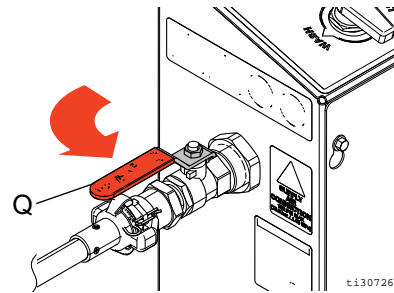

NOTE: If using non-pressurized water supply, turn the selector valve to BLAST to prime the pump.

NOTE: The system will not work unless the air supply valve is open.

5. Close the pot dump valve.
6. Fill the pot with water. Use the fill/flush valve or an external source. Add a rust inhibitor if necessary. See **Use Rust Inhibitor**, page 18.
7. Open the pot dump valve (J)

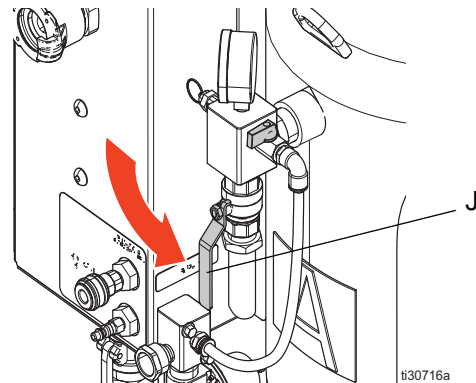

- Add abrasive material (see **Technical Specifications**, page 49 for capacity information).

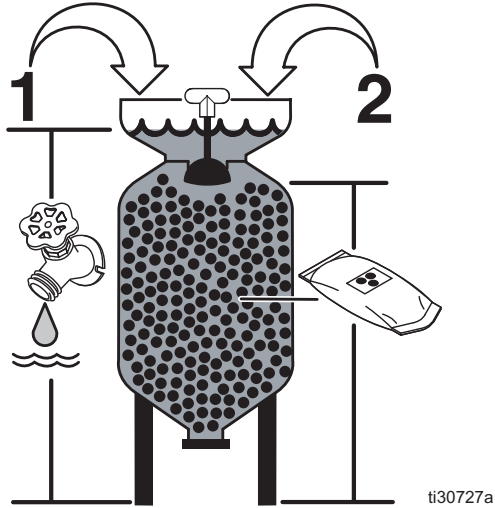

- Close the pot dump valve (J).
- Open the fill/flush valve until water is above the pop-up seal, then pull up on the pop-up handle to pressurize the pot.
- Close the fill/flush valve once the pot is pressurized.

NOTE: If using a non-pressurized water supply, fill the pot with water while in BLAST mode or use an external source.
- Turn the selector valve to WASH until the pump stops cycling to remove air from the wash tubing.

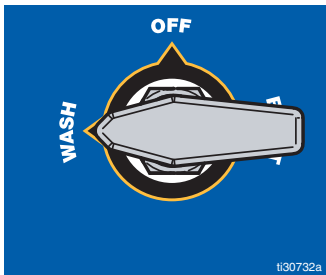

- Turn the selector valve to BLAST.



- Open the abrasive metering valve 1/4 turn.
- Check the pot pressure gauge to ensure the pot is pressurized. If the pot is not pressurized, pull up on the pop-up handle while the pump is cycling.

<p>To avoid injury due to a spray from wet media from the pot, always pressurize the pot before engaging the blast control switch and opening the abrasive ball valve (M).</p>				

- Engage the blast control switch and set the blast air pressure to the desired pressure.
- Open the abrasive ball valve (M).

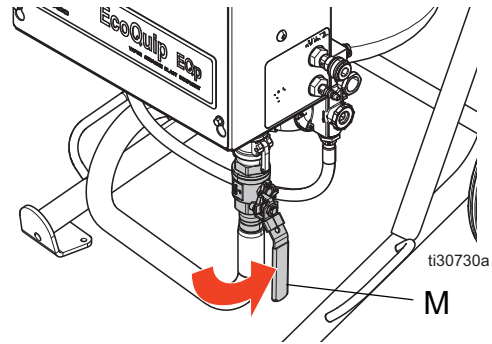

- While blasting, set the abrasive metering valve (T) until the desired performance is achieved.

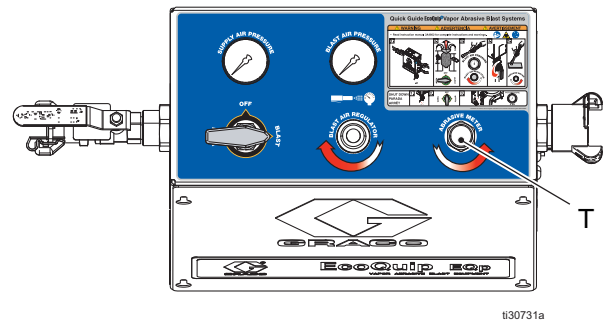

NOTE: You may have to wait 1-2 minutes for the abrasive material to reach the nozzle.

NOTE: Use a piece of test material similar to what you will be blasting. Always start as gently as possible and then increase the blast force as necessary to clean without doing any damage to the substrate.

Set the Abrasive Metering Valve

The abrasive metering valve should be opened in increments of 1/4 turn until desired performance is achieved.

The optimal turns open of the abrasive metering valve depends on blast pressure, blast hose, and nozzle combination. The lower the air flow, the less open the abrasive metering valve needs to be (see **Blast Pressure vs. Air Flow Chart** on page 17). A 0.5 in.

(12.7 mm) blast hose is required when air flow is less than 100 CFM (2.83 m³/min).

If the blast hose spits or sputters, too much media is being used for the given air flow through the system. To increase air flow, either the abrasive metering valve should be opened less, or a larger nozzle should be used.

General Application Guides

Blast Hose and Nozzle Selection Guidelines

Blast Hose ID	Reasons to Use This Hose	Nozzle	When to Use This Nozzle
0.5 in. (12.7 mm)	<ul style="list-style-type: none"> A compressor smaller than 185 CFM (5.24 m³/min) is available Increased control over the nozzle is desired Working in a small area or tight spaces where a lot of air flow is not desirable 	#3	Need increased nozzle pressures with a low air flow compressor (<70 CFM (1.98 m ³ /min))
		#4	General use nozzle for low air flow consumption and detail work
		#5	Largest pattern with 0.5 in. (12.7 mm) blast hose
1.0 in. (25.4 mm)	<ul style="list-style-type: none"> A 185 CFM (5.24 m³/min) compressor or larger is available Large surfaces need to be cleaned 100 feet (30 m) or 150 feet (45 m) of blast hose needs to be used. 	#5	General application nozzle allowing increased nozzle pressure with a 185 CFM (5.24 m ³ /min) compressor
		#6	Blasting steel or concrete with an easy to remove coating, or blasting wood using a 185 CFM (5.24 m ³ /min) compressor
		#7	Blasting large concrete, brick, or wood surfaces at low pressure with a 185 CFM (5.24 m ³ /min) compressor
		#8	Blasting large concrete, brick, or wood surfaces at low pressures with a larger compressor

Blast Pressure vs. Air Flow Chart

TABLE 1: 1/2 in. (12.7 mm) ID Blast Hose			
Use Low Flow Blast Circuit Manifold 17R853			
Gauge	Nozzle		
Blasting Pressure	#3 CFM (m³/min)	#4 CFM (m³/min)	#5 CFM (m³/min)
30 psi (2.0 bar, 0.20 MPa)			44 (1.2)
40 psi (2.8 bar, 0.28 MPa)		44 (1.2)	53 (1.5)
50 psi (3.5 bar, 0.35 MPa)	30 (0.85)	51 (1.4)	62 (1.8)
60 psi (4.1 bar, 0.41 MPa)	37 (1.0)	58 (1.6)	68 (1.9)
70 psi (4.8 bar, 0.48 MPa)	43 (1.2)	63 (1.8)	73 (2.1)
80 psi (5.5 bar, 0.55 MPa)	49 (1.4)	69 (2.0)	79 (2.2)
90 psi (6.2 bar, 0.62 MPa)	52 (1.5)	73 (2.1)	92 (2.6)
100 psi (6.9 bar, 0.69 MPa)	57 (1.6)	77 (2.2)	108 (3.1)
110 psi (7.6 bar, 0.76 MPa)	60 (1.7)	83 (2.4)	
120 psi (8.3 bar, 0.83 MPa)	63 (1.8)	98 (2.8)	
130 psi (9.0 bar, 0.90 MPa)	66 (1.9)	105 (3.0)	

TABLE 2: 1 in. (25.4 mm) ID Blast Hose				
Use High Flow Blast Circuit Manifold 25B051				
Gauge	Nozzle			
Blasting Pressure	#5 CFM (m³/min)	#6 CFM (m³/min)	#7 CFM (m³/min)	#8 CFM (m³/min)
30 psi (2.0 bar, 0.20 MPa)				108 (3.1)
40 psi (2.8 bar, 0.28 MPa)			109 (3.1)	138 (3.9)
50 psi (3.5 bar, 0.35 MPa)		108 (3.1)	139 (3.9)	159 (4.5)
60 psi (4.1 bar, 0.41 MPa)		124 (3.5)	152 (4.3)	183 (5.2)
70 psi (4.8 bar, 0.48 MPa)	104 (2.9)	139 (3.9)	169 (4.8)	209 (5.9)
80 psi (5.5 bar, 0.55 MPa)	122 (3.5)	153 (4.3)	190 (5.4)	236 (6.7)
90 psi (6.2 bar, 0.62 MPa)	142 (4.0)	166 (4.7)	213 (6.0)	262 (7.4)
100 psi (6.9 bar, 0.69 MPa)	148 (4.2)	180 (5.1)	232 (6.6)	296 (8.4)
110 psi (7.6 bar, 0.76 MPa)	157 (4.4)	198 (5.6)	253 (7.2)	----
120 psi (8.3 bar, 0.83 MPa)	166 (4.7)	215 (6.1)	----	----
130 psi (9.0 bar, 0.90 MPa)	----	----	----	----

■ = Not a recommended hose and nozzle combination for given pressure.

How to use the Tables 3 and 4:

1. Determine air flow based on blast pressure, blast hose and nozzle size from Table 1 or 2.
2. Determine pressure drop based on air flow using Table 3 or 4.

TABLE 3: Pressure drop from the Blast Pressure Gauge to Nozzle using a 50 ft - 1/2 in. ID (15.2 m - 12.7 mm ID) Blast Hose Dependent on Air Flow												
Air Flow CFM (m³/min)	30 (0.84)	40 (1.12)	50 (1.4)	60 (1.70)	70 (1.98)	80 (2.27)	90 (2.55)	100 (2.83)	110 (3.11)	120 (3.39)	130 (3.68)	140 (3.96)
Pressure Drop psi (bar)	3 (0.207)	5 (0.345)	7 (0.483)	10 (0.689)	13 (0.896)	17 (1.17)	20 (1.38)	25 (1.72)	30 (2.07)	35 (2.41)	40 (2.76)	45 (3.10)

TABLE 4: Pressure drop from the Blast Pressure Gauge to Nozzle using a 50 ft - 1 in. ID (15.2 m - 25.4 mm ID) Blast Hose Dependent on Air Flow										
Air Flow CFM (m³/min)	100 (2.83)	120 (3.40)	140 (3.96)	160 (4.53)	180 (5.10)	200 (5.66)	220 (6.23)	240 (6.80)	260 (7.36)	280 (7.93)
Pressure Drop psi (bar)	12 (0.827)	14 (0.965)	16 (1.10)	18 (1.24)	20 (1.38)	22 (1.52)	23 (1.59)	24 (1.65)	26 (1.79)	27 (1.86)

Use the Wash Feature



The wash feature uses water (without abrasive) to rinse areas that have been blasted with abrasive.

NOTICE

There will always be some residual abrasive in the blast hose. Never use the wash feature on any surface other than where you have blasted, or intend to blast. It can dull the surface.

1. Close the abrasive ball valve (M).

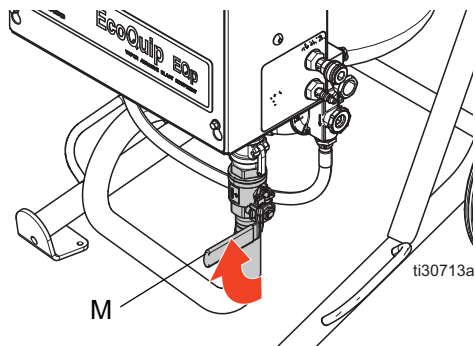

2. Turn the selector valve to WASH.



3. Blast 1-2 minutes until the abrasive is cleared from the hose.

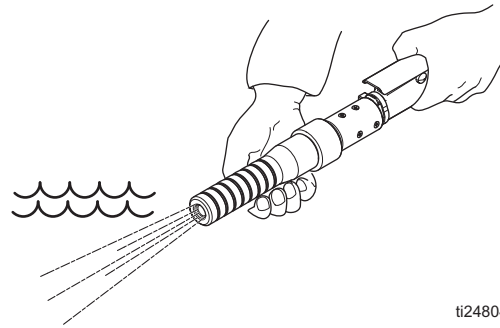

4. The equipment is now ready to wash any previously blasted surfaces.

Use Rust Inhibitor

When rust is not permissible on a finished surface, you may use a suitable rust inhibitor with the system. Follow this procedure and all procedures recommended by the rust inhibitor manufacturer.

1. Mix water and the rust inhibitor to the manufacturer's recommended ratio for your job environment.

NOTE: Either mix the water and the rust inhibitor in an appropriate external container and use the container to fill the pressure pot, or fill the pressure pot with water and add the rust inhibitor to the pot until the mixture reaches the recommended ratio.

2. Add the abrasive.
3. Monitor and refill the pressure pot. Maintain the proper water to rust inhibitor ratio.

NOTE: During operation, if the actual water to rust inhibitor ratio no longer matches the recommended ratio, drain the pressure pot and repeat this procedure.

Refill the Pot with Abrasive



1. Close the abrasive ball valve (M).

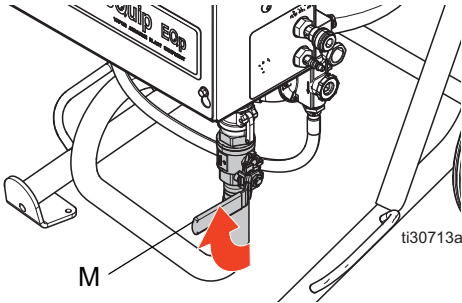

2. Turn the selector valve to OFF.



3. Open the pot dump valve (J) to drain water from the pot.

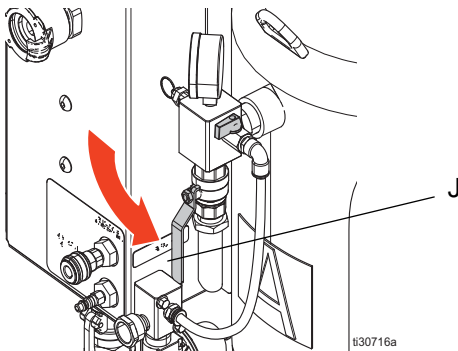

NOTE: Be prepared to capture the water that will be drained from the pot. All disposals must comply with national, state, and local regulations.

4. Add the abrasive (see **Technical Specifications**, page 49 for capacity information) and continue to step 7 from **Set Up the Equipment**, page 13.

Standby

1. Close the abrasive ball valve (M).

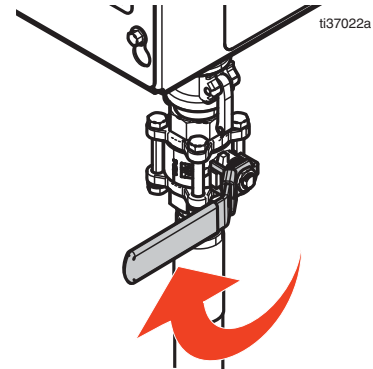

NOTICE

To prevent material from packing out and damaging the blast hoses, do not shut off your air compressor during Standby.

2. Turn the selector valve (W) to OFF.



3. Open the pot dump valve (J) until the pot pressure gauge reaches 0 psi.

POT PRESSURE



0 psi

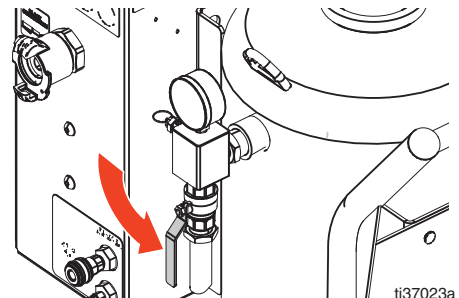

Shutdown



1. When you have finished blasting, perform wash until all of the abrasive is flushed from the blast hose (see **Use the Wash Feature**, page 18).
2. Turn the selector valve to OFF, and with the abrasive ball valve closed, continue to blast until all water is cleared from the hose. This is to dry the inside of the hose for storage.



3. Perform **Pressure Relief Procedure**, page 8.

Drain the Pot



With Pressurized Water Supply:

1. Turn the selector valve to OFF.

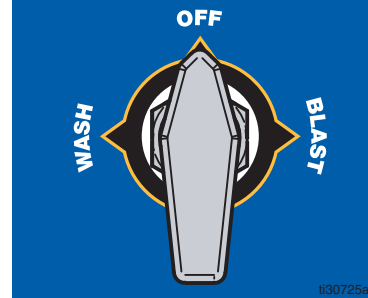

2. Open the abrasive ball valve (M).

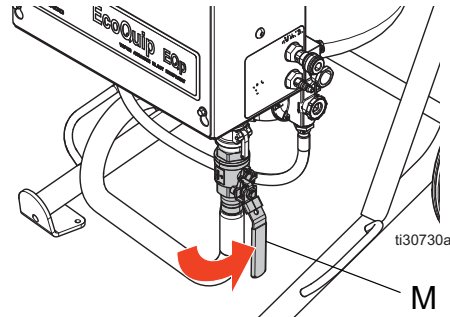

3. Open the pot dump valve (J) to relieve pressure in the pinch hose and pot.

NOTE: For additional information on the Pinch Hose, see page 11.

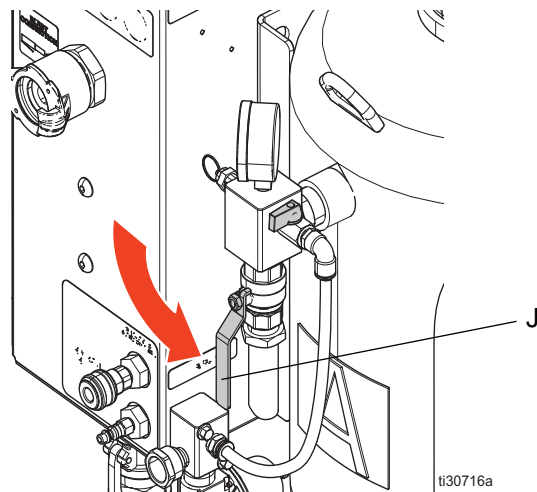

4. Close the pot dump valve (J) once the pot pressure gauge reads 0 psi.

5. Close the abrasive ball valve (M).

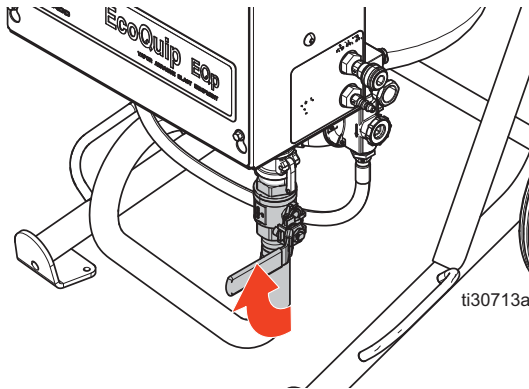

6. Disconnect the abrasive ball valve cam-lock by removing the coupler pins and pulling the rings out and up to pull the two cams away from the groove.

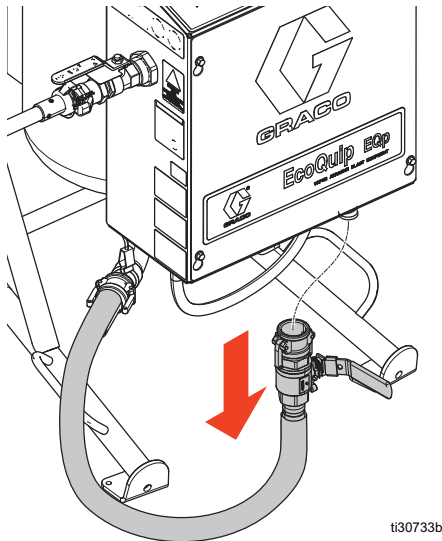

NOTE: Be prepared to capture the water that will be drained from the pot. All disposals must comply with national, state, and local regulations.

7. Open the fill/flush valve (XD). Once water is above the pop-up seal, pull up on the pop-up handle to pressurize the pot.

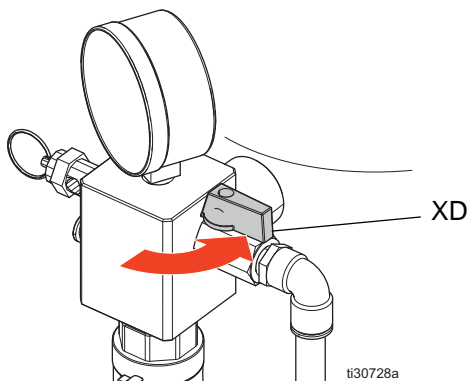

8. Place a bucket under the abrasive hose. Slowly open the abrasive ball valve to flush abrasive material from the pot.

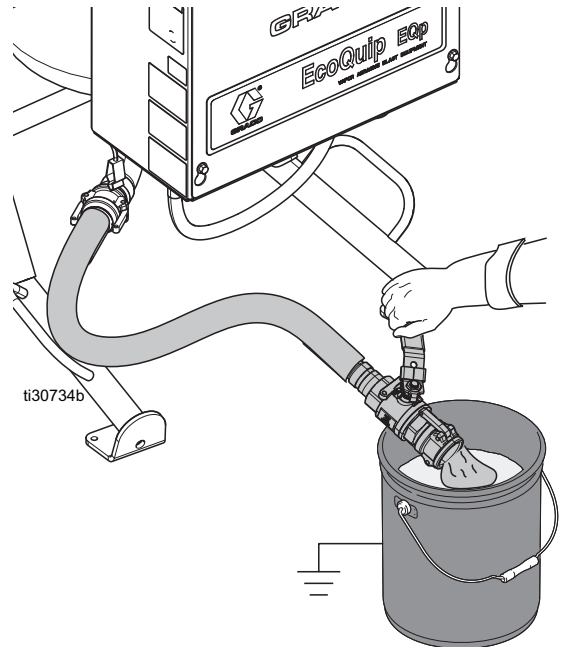

NOTE: Once the water surges from the abrasive hose, close the ball valve and pull up on the pop-up handle once water is above the pop-up seal to re-pressurized the pot. Repeat until all abrasive has been emptied from the pot.

9. Close the fill/flush valve.

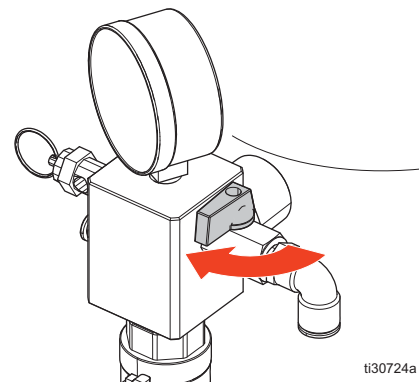

10. Open the abrasive ball valve and drain the pot of water.

11. Connect the abrasive hose.

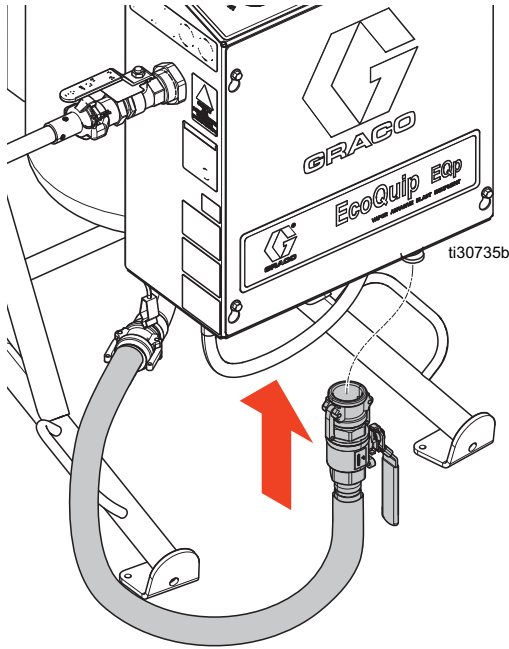

NOTE: The system must be winterized if it will be exposed to temperatures below freezing (see **Winterize the Equipment**, page 24).

With Non-Pressurized Water Supply:

1. Open the abrasive ball valve (M).

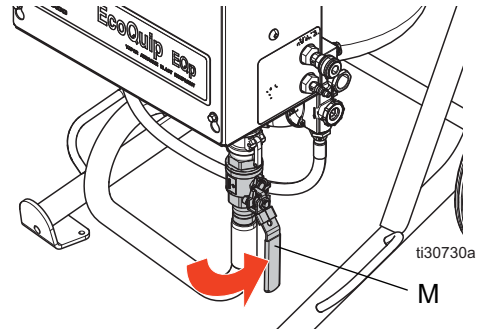

2. Open the pot dump valve (J) to relieve pot pressure and pressure in the pinch hose.

NOTE: For additional information on the Pinch Hose, see page 11.

3. Close the abrasive ball valve (M).

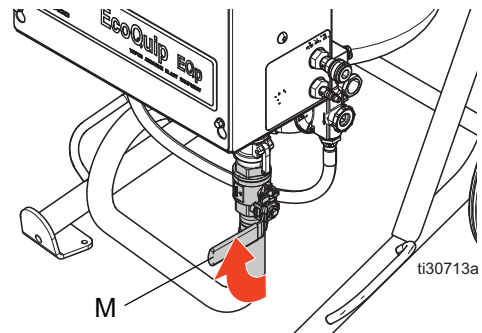

4. Disconnect the abrasive ball valve cam-lock by removing the coupler pins and pulling the rings out and up to pull the two cams away from the groove.

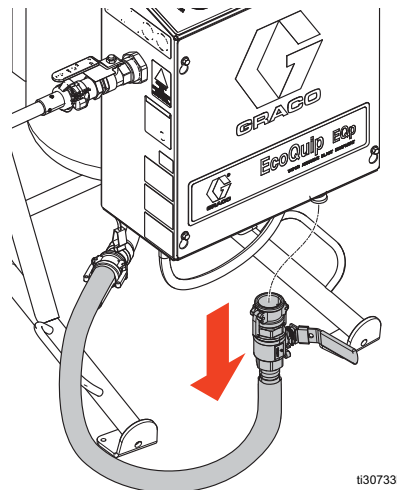

NOTE: Be prepared to capture the water that will be drained from the pot. All disposals must comply with national, state, and local regulations.

- Turn the selector valve to BLAST and when water is above the pop-up seal, pull up on the pop-up handle to pressurize the pot.

NOTE: The abrasive metering valve must be open for water to flow to the pot.

- Place a bucket under the abrasive hose. Slowly open and close the abrasive ball valve to flush abrasive material from the pot. Repeat several times. Once no abrasive material flows from the hose, close the abrasive ball valve. Turn the selector valve to OFF.

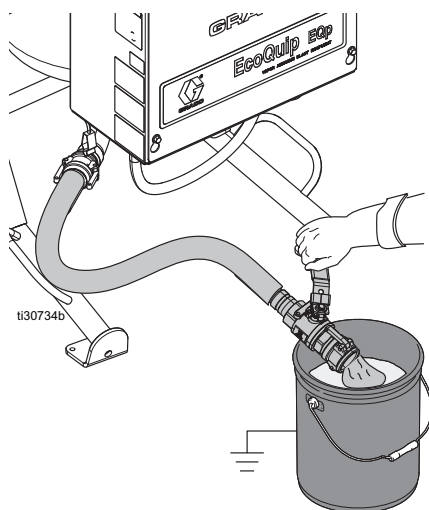

- Open the abrasive ball valve and drain the pot of water.
- Connect the abrasive hose.

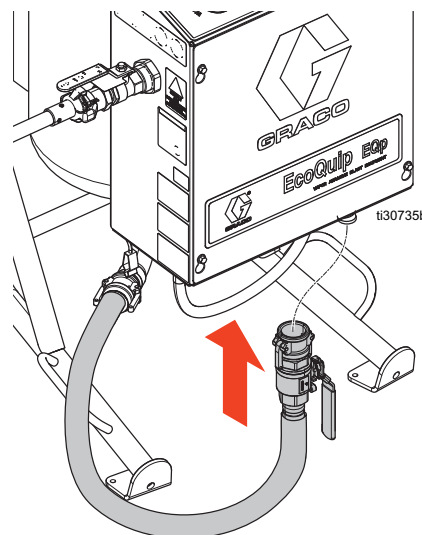

NOTE: The system must be winterized if it will be exposed to temperatures below freezing (see **Winterize the Equipment**, page 24).

Winterize the Equipment



NOTICE

Vapor abrasive blasters must be winterized whenever there is a possibility of freezing temperatures during storage to avoid damage to the equipment.

1. Drain the pot (see **Drain the Pot** page 20).
2. Close the air supply valve (Q).
3. Disconnect the water supply.
4. Remove the pump inlet hose from the pump inlet and drain.

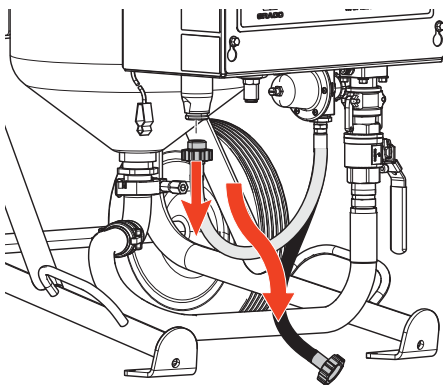

ti30736b

NOTE: All disposals must comply with national, state, and local regulations.

5. Connect the included siphon hose to the pump, then insert the end into a windshield wash container. Choose a windshield wash with a rating that will protect the equipment for the lowest temperature in your area.

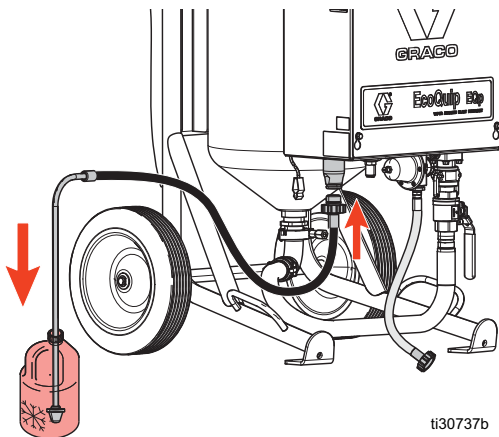

ti30737b

6. Open the air supply valve.
7. Turn the selector valve to BLAST with the abrasive metering valve 1/4 turn open until the blast water tubing is full of windshield wash.



ti30729a

8. Turn the selector valve to WASH. Confirm that the wash tubing fills with windshield wash.
9. Close the air supply valve.
10. Remove fill/flush line from the water supply manifold and drain water. Reconnect the fill/flush line.

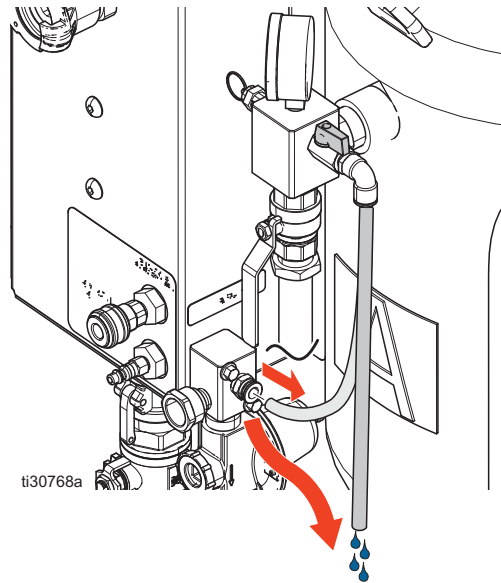

ti30768a

11. Open all ball valves and the abrasive metering valve.
12. Reconnect the pump inlet hose.

NOTICE

When ice forms behind the seals, the seals can become damaged. During storage, position all ball valves in the open position.

Troubleshooting



Always perform the **Pressure Relief Procedure**, page 8, before servicing or repairing any equipment.

Problem	Cause	Solution
Unable to fill or pressurize the pot with water	Air supply valve is closed.	Open the air supply valve.
	The air supply is inadequate.	Make sure the air compressor is capable of supplying the minimum air flow requirement for your system (see Technical Specifications , page 49). Make sure the air inlet pressure gauge reads 100-150 psi (6.8–10.3 bar, 0.68–1.03 MPa). If the gauge does not read 100-150 psi, check the air compressor for proper setup. Make sure the air inlet filters are clean, and replace if necessary.
	Inadequate water supply to the pump.	Systems with water tanks: Make sure the water tank is full and the inlet ball valve is open. Clean or replace water inlet filter if necessary. Make sure all fitting connections are tight.
		Systems with pressurized supply connection: Make sure the water supply connection is connected and pressurized. Check that the water supply meets appropriate pressure and flow requirements (see Set Up the Equipment on page 13, step 1). Make sure all fitting connections are tight. Check inlet water pressure regulator for proper flow direction installation (see Parts on page 34). Check the inlet water pressure regulator screen filter for debris, clean if possible. Replace regulator if no flow can be passed through the regulator.
		Make sure the water inlet pressure regulator is not used if siphon feeding or using an external water tank.
	The water pump air regulator is malfunctioning.	Disengage the blast control switch (B). Adjust the pump inlet air pressure regulator until the pump air pressure regulator gauge reads 50 psi (3.4 bar, 0.34 MPa). If you are unable to attain this setting, check the air inlet filters and make sure the supply air pressure is greater than or equal to 50 psi. If the above steps do not resolve issue, replace the pump air pressure regulator.
The water pump is malfunctioning.	Rotate 3-way selector valve to WASH position. Verify that pump stalls. If pump continues to creep or will not prime, refer to manual 3A5023 for pump service.	

Problem	Cause	Solution
Unable to fill or pressurize the pot with water (continued)	The pop-up seal does not seal properly.	Make sure the pop-up is clean and free of debris in the o-ring sealing area. Check for proper pop-up alignment in the closed position (there should be no gaps between the o-ring and the pop-up). Remove the o-ring and make sure the o-ring gland is clear of debris. Replace the o-ring and/or pop-up if worn.
	The water pressure regulator is malfunctioning.	Adjust the water pressure regulator until the pot pressure gauge reads 185 psi (12.75 bar, 1.275 MPa). If this adjustment is not possible, service the water pressure regulator (see manual 309474).
The blast hose recoils heavily when the blast control switch (B) is engaged. Large slugs of abrasive and water are ejected from nozzle.	The abrasive ball valve was left open during shut down.	See Standby , page 19.
	The abrasive ball valve is worn.	With the pot pressurized, the selector valve in the BLAST position, and the abrasive ball valve closed, engage the blast control switch (B) and check to make sure the pump is stalled. If the pump rod is cycling, replace the abrasive ball valve (M).
	The pinch hose is worn.	With the pot pressurized and the abrasive ball valve open, check to make sure the pump is stalled. If the pump rod is cycling, replace the pinch hose (see Replace the Pinch Hose , page 31).
The pot pressure relief valve (K) is discharging water.	The water pressure regulator is malfunctioning.	Adjust the water pressure regulator to 185 psi (12.75 bar, 1.275 MPa). If this adjustment is not possible, service the water pressure regulator (see manual 309474).
	The pressure relief valve has failed.	Replace the pressure relief valve if weeping occurs at or below 185 psi (12.75 bar, 1.275 MPa).
No blast air flow when the blast control switch (B) is engaged. The water pump does cycle while the blast control switch is engaged.	The adjustable blast regulator is not adjusted to the correct pressure.	Adjust the blast regulator to the desired pressure while the blast control is engaged.
	The tubing to the main air regulator is not properly connected or there are air leaks in the fittings or tubing.	See Tubing Schematic , page 46. Check for leaks at connection points.
	The adjustable blast air regulator is malfunctioning.	Clean or replace the adjustable blast air regulator.
	The main air regulator is malfunctioning.	Disassemble the main air regulator and inspect components. Replace or repair parts as necessary. See Parts , page 34.

Problem	Cause	Solution
<p>No blast air flow when the blast control switch (B) is engaged. The water pump does not cycle while the blast control switch is engaged.</p>	<p>The air supply valve is closed.</p>	<p>Disengage the emergency stop (Q).</p>
	<p>The air supply is inadequate.</p>	<p>Make sure the air compressor is capable of supplying the minimum air flow requirement for your system (see Technical Specifications on page 48, for more information). Make sure the air inlet pressure gauge reads 100-150 psi (6.8–10.3 bar, 0.68–1.03 MPa). If the gauge does not read 100–150 psi, check the air compressor for proper setup (consult your air compressor manual, see Related Manuals on page 3).</p>
	<p>The pneumatic blast control circuit is malfunctioning.</p>	<p>Actuate the blast control switch (B) and check for proper spool valve actuation in the 4-way solenoid valve. If no actuation occurs, check the blast control switch and twin-line by disconnecting the yellow tube at the enclosure male quick disconnect and engage the control switch. If no air comes from the fitting, check for signal air at the blast control switch. Replace the pneumatic blast control switch if signal air does not pass through the valve when the handle is depressed. If the switch is functioning, ensure that the yellow tubing inside the control box is properly connected and clear any obstructions. If the tubing is clean, replace the 4-way solenoid valve.</p>

Problem	Cause	Solution
<p>While in BLAST mode, with the blast control switch (B) engaged, air is flowing from the nozzle but little or no abrasive is flowing from the nozzle.</p>	<p>The abrasive ball valve is closed.</p>	<p>See Set Up the Equipment on page 13.</p>
	<p>The abrasive metering valve is not properly set.</p>	<p>See Set Up the Equipment on page 13.</p>
	<p>The pot does not have a sufficient amount of abrasive.</p>	<p>See Refill the Pot with Abrasive on page 19.</p>
	<p>The pinch valve does not open.</p>	<p>Engage the blast control switch (B) and check for actuation of the pinch valve. If there is no actuation, disconnect the orange tubing at the pinch valve. If the pinch valve opens and source air is coming from the orange tubing, confirm that the tubing is correctly routed. If the pinch valve does not open, replace it. If the pinch valve opens and there is no source air coming from the tubing, inspect the mufflers on the 4-way valve for debris. If debris is not present, clean or replace the 4-way valve.</p>
	<p>Obstruction in blast outlet circuit.</p>	<p>Follow Debris in Media Path on page 32 to check for obstruction.</p>
	<p>There is an obstruction inside the pot or inside the abrasive hose between the pot and the enclosure.</p>	<p>Follow Debris in Media Path on page 32 to check for obstruction.</p>
	<p>The pot pressure is too low.</p>	<p>With the blast control disengaged, allow the pot to pressurize and wait for the pump to stall. If the pot pressure gauge does not reach 185 psi (12.75 bar, 1.275 MPa), see the “Unable to fill or pressurize the pot with water” problem listed in this table.</p>

Problem	Cause	Solution
<p>The blast control switch (B) is not engaged, but blasting occurs.</p>	<p>The air supply is inadequate.</p>	<p>Make sure the air compressor is capable of supplying the minimum air flow requirement for your system (see Technical Specifications on page 49). Make sure the air inlet pressure gauge reads 100-150 psi (6.8–10.3 bar, 0.68–1.03 MPa). If the gauge does not read 100–150 psi, check the air compressor for proper setup (consult your air compressor manual, see Related Manuals, page 3).</p>
	<p>The main air regulator is malfunctioning or is stuck open.</p>	<p>Make sure the air compressor is capable of supplying the minimum air flow requirement for your system (see Parts, page 34).</p>
	<p>The pneumatic blast control circuit is malfunctioning.</p>	<p>Actuate the blast control switch (B) and check for proper spool valve actuation in the 4-way valve. If no actuation occurs, check the blast control switch by disconnecting the yellow tube at the enclosure male quick disconnect and engage the control switch. If only a little air comes from the fitting, check the twin-line hose for damage or crimping and check the pneumatic blast control filter. If the twin-line and filter are clean, replace the pneumatic blast control switch. If the switch is functioning, make sure the yellow tubing inside the control box is properly connected and clear any obstructions. If all above items are functional, replace the 4-way solenoid valve.</p>
<p>While the blast control switch (B) is engaged, the blast air flow is fluctuating.</p>	<p>The supply air pressure is fluctuating.</p>	<p>Make sure the compressor meets minimum flow requirements and is operating properly. See Technical Specifications, page 49, for more information.</p>
	<p>The main air regulator is malfunctioning or is stuck open.</p>	<p>Disassemble the main air regulator and check for obstructions. Replace or repair parts as necessary (see Parts, page 34).</p>
	<p>The pneumatic blast control circuit is malfunctioning.</p>	<p>Actuate the blast control switch (B) and check for proper spool valve actuation in the 4-way valve. If no actuation occurs, check the blast control switch by disconnecting the yellow tube at the enclosure male quick disconnect and engage the control switch. If only a little air comes from the fitting, check the twin-line hose for damage or crimping and check the pneumatic blast control filter. If the twin-line and filter are clean, replace the pneumatic blast control switch. If the switch is functioning, ensure that the yellow tubing inside the control box is properly connected and clear of obstructions. If all above items are functional, replace the 4-way solenoid valve.</p>

Problem	Cause	Solution
The blast spray pattern is sputtering or irregular.	The air supply is inadequate.	Make sure the air compressor is capable of supplying the minimum air flow requirement for your system (see Technical Specifications, page 48). Make sure the air inlet pressure gauge reads 100-150 psi (6.8–10.3 bar, 0.68–1.03 MPa). If the gauge does not read 100-150 psi, check the air compressor for proper setup (consult your air compressor manual, see Related Manuals , page 3). Make sure the air inlet filters are clean and replace if necessary.
	The blast hose was not properly cleaned out after previous use.	See Standby , page 19.
	The abrasive metering valve setting is too high for the blast pressure and/or abrasive type.	See Set the Abrasive Metering Valve , page 15.
	The pot does not have a sufficient amount of abrasive.	See Refill the Pot with Abrasive , page 19.
	There is an obstruction in the nozzle	Remove the nozzle and inspect for blockage, buildup, or damage. Replace if necessary.
	There is an obstruction inside the pot or inside the abrasive hose between the pot and the enclosure.	Follow Debris in Media Path on page 32, to check for obstruction.
	The fill/flush valve is open.	Close the fill/flush valve.
Too much dust occurs during blasting.	There is not enough water in abrasive mixture.	The media is too fine--use a coarser media.
	The blast pressure is too high.	Decrease the blast pressure and re-evaluate the dust level.
Too much water is coming from the nozzle in BLAST mode.	The abrasive material is too coarse.	If possible, use at least a 40 mesh abrasive material. Otherwise, decrease the CPM set point until the pattern improves.
	The abrasive metering valve setting too high for blast pressure and/or abrasive type.	See Set the Abrasive Metering Valve , page 15.
	The fill/flush valve is open.	Close the fill/flush valve.
In WASH mode, little or no water is flowing from the nozzle.	Wash down line is clogged with media or other debris.	Remove wash down line and clear debris.
	Obstruction in blast outlet manifold.	Follow Debris in Media Path on page 32, to check for obstruction.

Repair

Replace the Pinch Hose



1. Perform **Pressure Relief Procedure**, page 8.
2. Remove the claw coupler (CP).
3. Remove lock nut (S1) on the exterior of the control box.
4. Remove the clamp (HC) connecting the blast outlet (B) to the blast inlet assembly (BI).
5. Loosen the lock nut (S2) on the interior of the control box. Move the blast inlet assembly (BI) to the left to allow room to remove the blast circuit.
6. Remove check valve components (G1, G2, G3, G4).
7. Clean off any abrasive material stuck to the check valve components (G1, G2, G3, G4, G5) to allow for proper operation of the check valve.

NOTICE

Check valve components coated in abrasive material can prevent proper operation of the check valve. Improper check valve operation can allow abrasive material to enter the main air regulator and interfere with regulator operation.

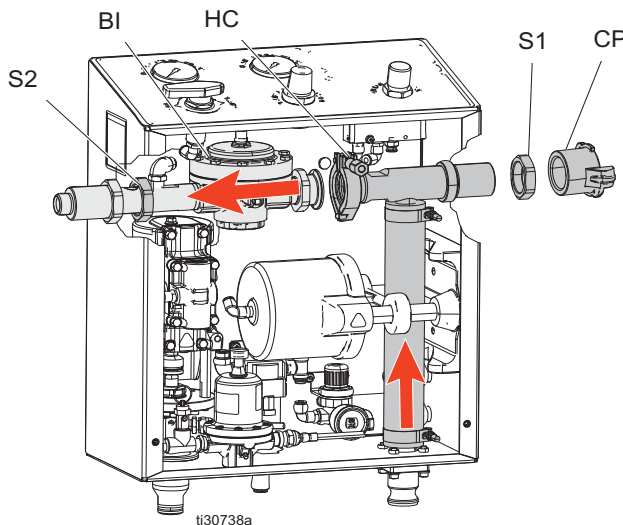

8. Remove the bottom hose clamp (C2).
9. Pull the pinch hose (PH) out of the box.

NOTE: Use the blast circuit (BC) as a handle and twist while pulling.

10. Loosen the remaining hose clamp and remove the pinch hose from the circuit.

Install the Pinch Hose

1. Place both hose clamps (C1, C2) on the pinch hose (PH). Leave 1/4 in. of hose exposed on the ends.
2. Slide the pinch hose (PH) onto the barb at the blast circuit (BC).
3. Reinstall the blast circuit (BC) and pinch hose (PH) into the box through the pinch valve.
4. Tighten lock nut (S1).
5. Inspect gasket (G1) and replace if necessary, install between the blast inlet assembly and the blast outlet (B).
6. Install check valve components (G2, G3, G4) with the plunger head o-ring (G5) facing the air regulator between the blast inlet assembly (B1).
7. Install and tighten clamp (HC) to 15 ft-lb (20.3 N•m).
8. Tighten the hose clamps (C1, C2) to 85 +/- 5 in-lb (9.6 +/- 0.56 N•m).
9. Tighten (S2).
10. Install the claw coupler (CP).

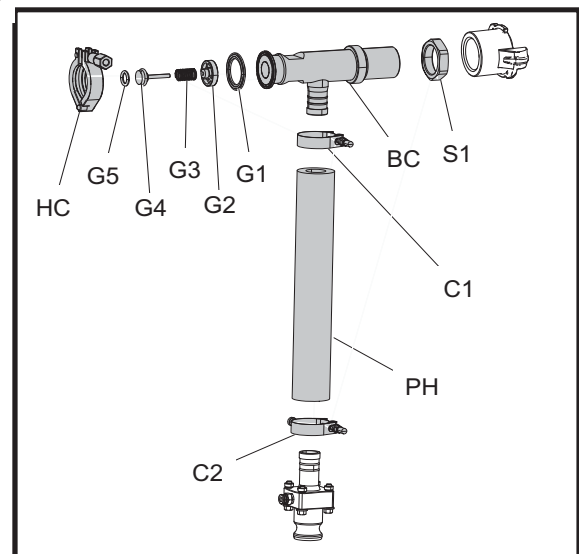

Debris in Media Path



1. Perform **Drain the Pot** procedure, page 20, to remove as much media and water as possible.
2. Perform **Pressure Relief Procedure**, page 8.
3. Disconnect the abrasive hose at the control box, and disconnect the blast hose. Shine a flashlight in through the blast outlet connection. Inspect the interior of the pinch hose and blast circuit outlet for debris. If debris or packed-out media is found, remove then reinstall the blast hose and abrasive hose and resume blasting.

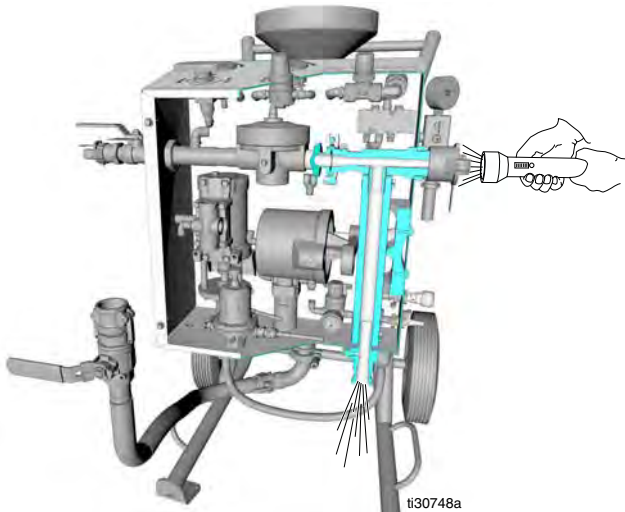

4. Remove the pot funnel assembly to gain access to the inside of the pot.

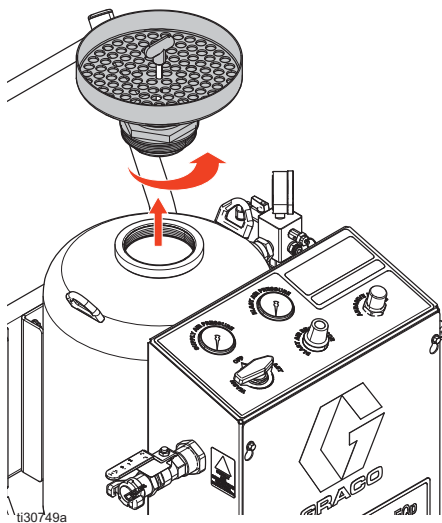

5. If visible, remove large debris and proceed to step 11. If water and media still remain in the pot and no debris is visible, proceed to step 6.
6. Remove the abrasive hose from the control box and pot at the cam-lock fittings. If media flows freely from the pot, debris is stuck in the abrasive hose. Clear the hose and reinstall.

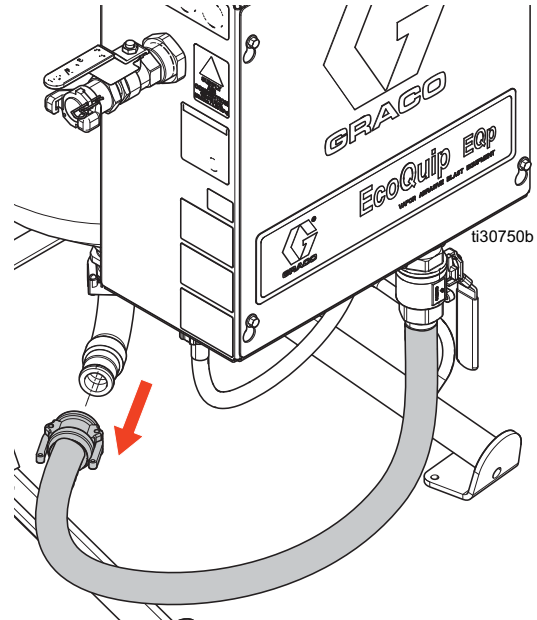

7. If media is still stuck in the pot, loosen the clamp to remove the outlet manifold.

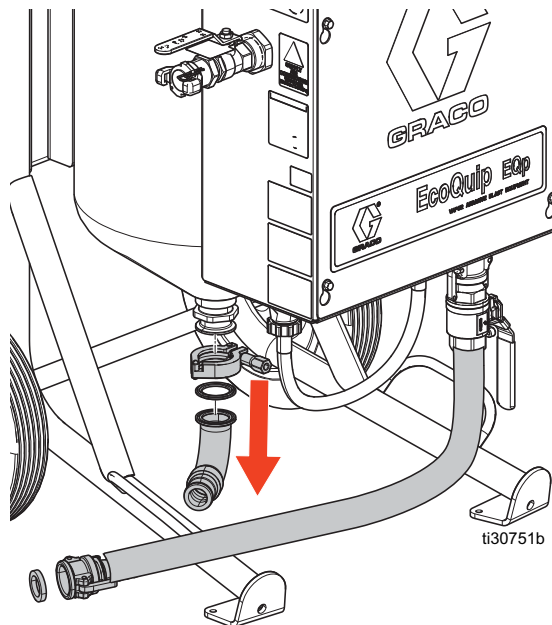

8. Probe inside the pot from the outlet until the debris is found.

9. Remove debris, inspect the gasket and replace if damaged. Reinstall the outlet manifold and torque the clamp to 15 ft-lb (19.5 N•m).

NOTE: When debris is cleared, media should freely flow from the pot outlet. The pot will need to be completely flushed before the outlet manifold can be reinstalled. All disposals must comply with national, state and local regulations.

10. Connect the abrasive hose at the cam-lock connections.
11. Inspect the post funnel assembly gaskets and replace if necessary. Reinstall the pot funnel assembly and torque to 70 +/- 5 ft-lb (95 +/- 7 N•m).

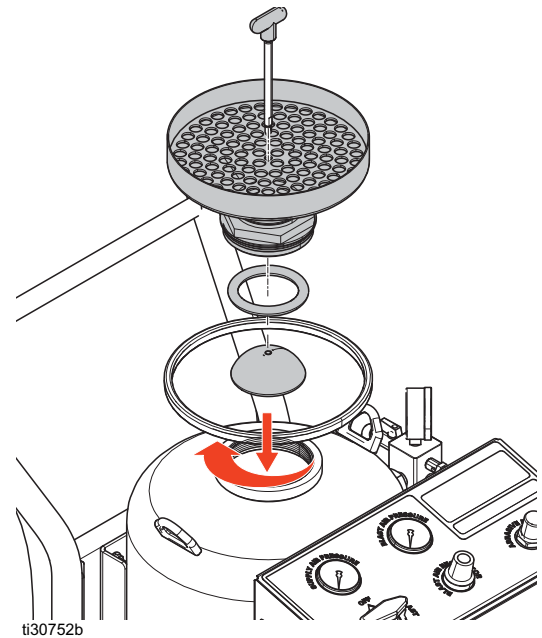

Parts

EQp

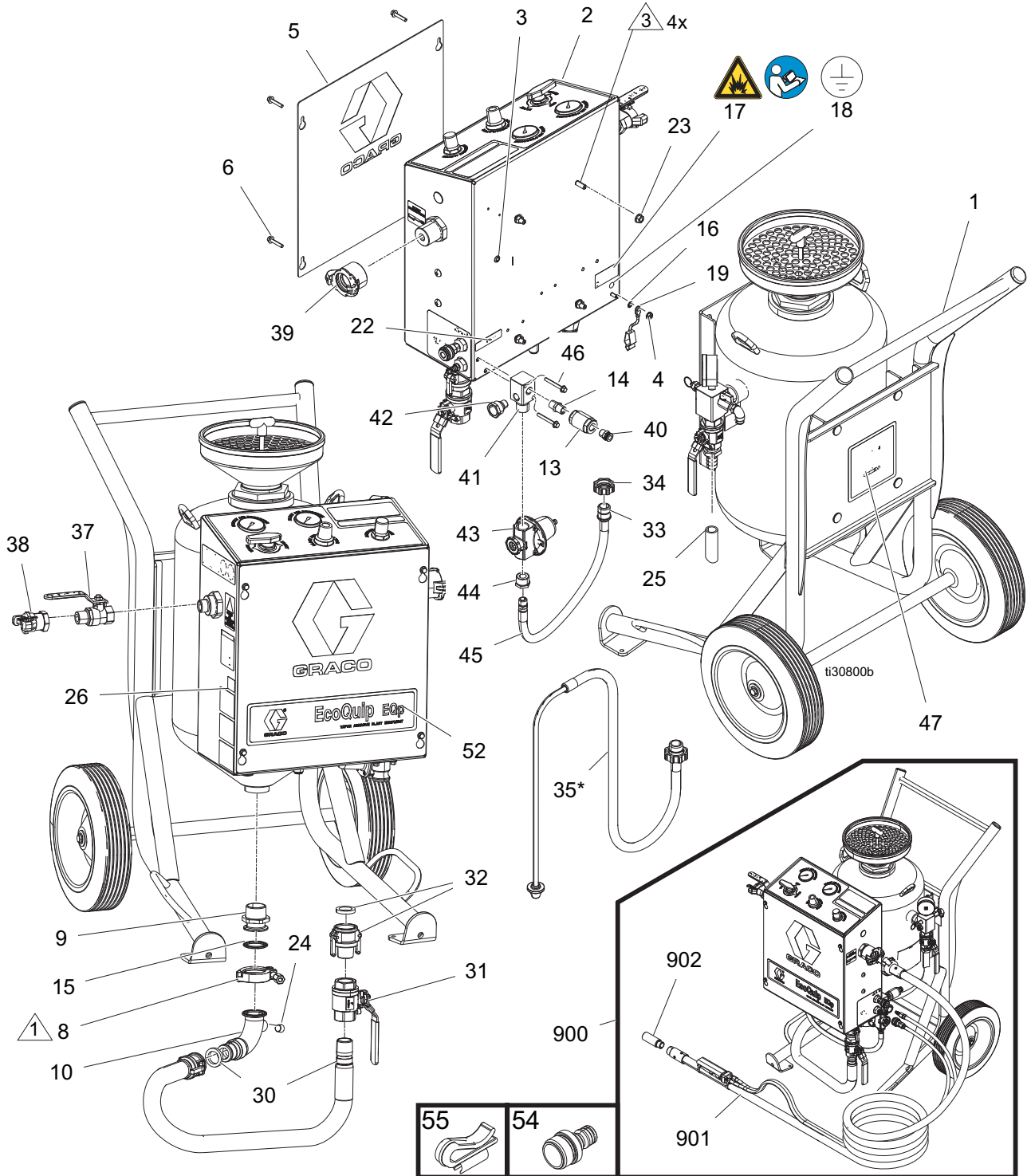

⚠ Torque clamp to 15 +/- 2 ft-lb after hose is connected.

⚠ Apply anti-sieze to studs.

EQp Parts List

Ref.	Part	Description	Qty.	Ref.	Part	Description	Qty.
1	-----	PRESSURE pot, assembly, 1.5 in. cart	1	35a†	24F148	KIT, hose, suction, 5 gal, 3/8 od	1
2	17T712	ENCLOSURE, EcoQuip, EQp	1	35b‡	17S897	KIT, hose, suction, 5/8 OD, 80 mesh	1
3	129090	GROMMET, 9/32 in., ID, rubber, black	1	37	113218	VALVE, ball, vented, .750	1
4	115942	NUT, hex, flange head	1	38	113430	COUPLING, universal	1
5	17S059	COVER, enclosure, EcoQuip, painted	1	39	17R845	FITTING, claw, coupler, 1-1/4 nps	1
6	120444	SCREW, hex hd, flanged	4	40	128638	FITTING, PTC, straight, 3/8 npt, 3/8 t	1
8	128791	CLAMP, triclamp, 1.5, hex wing nut	1	41	25P576	MANIFOLD, water inlet	1
9	17H273	ADAPTER, triclamp, 1-1/4 npt, sst	1	42	129577	FITTING, swivel, garden to npt	1
10	17L631	MANIFOLD, unequal-tee	1	43	17J372	VALVE, pressure reducing, 3/4 npt	1
13	EQ1034	VALVE, check, 3/8 in., sst	1	44	116350	BUSHING, pipe	1
14	167702	NIPPLE, pipe	1	45	17R836	HOSE, pump, low pressure (includes 33)	1
15	680454	GASKET, sanitary fitting	1	46	129705	BOLT, flange hd, serrated, 1/4, cs	2
16	100985	WASHER, lock ext	1	47	MTA915	LABEL, G, control box	1
17▲	16P265	LABEL, safety, warning, explosion	1	52	-----	LABEL, branding, EcoQuip, EQp	1
18▲	186620	LABEL, symbol, ground	1	54	287643	ADAPTER, garden hose	1
19	237686	WIRE, ground assembly w/ clamp	1	55	130078	HOLDER, clip, siphon tube	1
23	128226	NUT, flange, 3/8-16, sst	4	900	-----	See Models on page 3.	
24	112306	PLUG, pipe, 3/8 npt, sst	1	901	-----	See Blast Control Hoses on page 43.	
25	EQ1360	HOSE, braided, clear, 3/4 id	3	902	-----	See Nozzles on page 43.	
26	15Y118	LABEL, Made in the USA	1			▲ Replacement safety labels, tags, and cards are available at no cost.	
29	206994	FLUID, TSL 8 oz bottle	1			† Assembled on units with date code E17 or earlier.	
30	17L329	HOSE, inlet media	1			‡ Assembled on units with date code F17 or later.	
31	17R833	VALVE, ball, 2pc, sst, 1 in. npt	1				
32	17J329	COUPLER, cam-lock, sst, 1 nptf	1				
33	117559	O-RING	1				
34	15E813	NUT, jam	1				

EQp (continued)

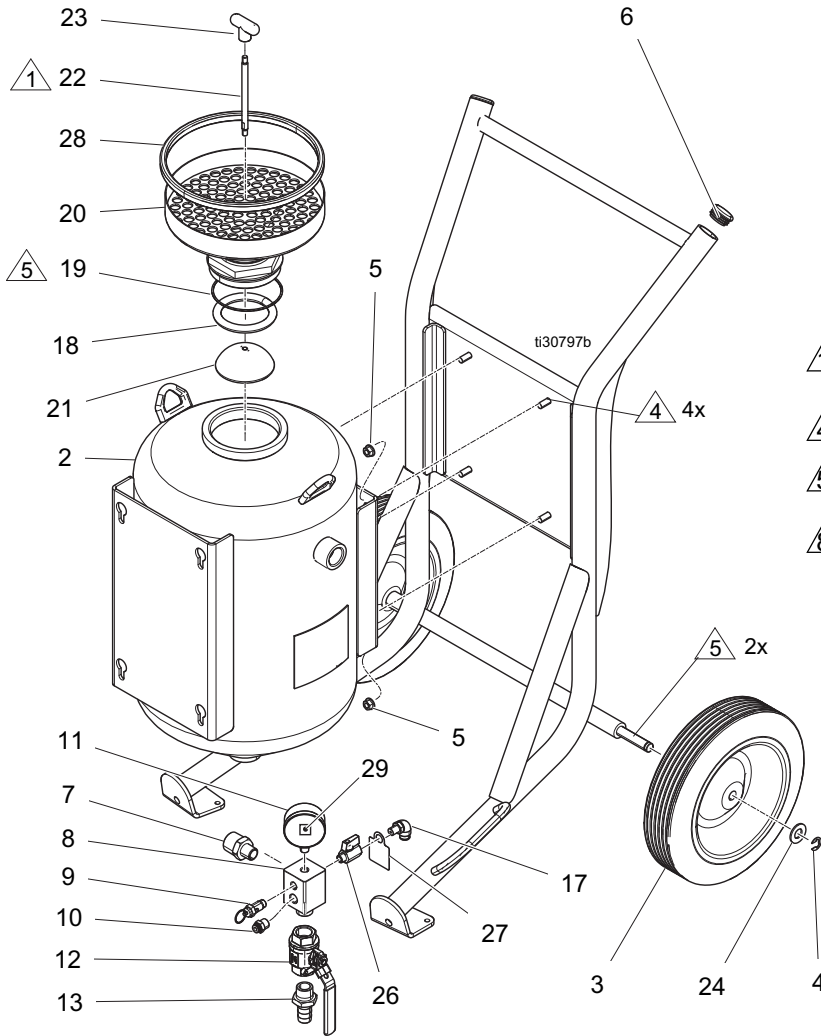

▲1 Apply thread sealant and use a wrench to assemble with the flat side inside (21).

▲4 Apply anti-sieze to studs.

▲5 Apply grease before assembling wheels and o-ring.

▲6 Torque to 70 +/- 5 ft-lb (94 +/- 6.7 N•m).

EQp Parts List (continued)

Ref.	Part	Description	Qty.	Ref.	Part	Description	Qty.
1	25P573	CART, painted, EcoQuip	1	13	EQ1012	FITTING, nipple barb hose 3/4 in.	1
2	17T884	PRESSURE POT, blast media, 2.0 cu ft	1	17	121018	FITTING, elbow, male, swivel, 1/4 npt	1
3	17S058	WHEEL, semi pneumatic, offset (includes 4, 24)	2	18	17R837	O-RING, 3 in. ID, 5 in. cross section	1
4	101242	RING, retaining, ext.	2	19	104280	PACKING, o-ring	1
5	128226	NUT, flange, 3/8-16, sst	4	20	17R838	FUNNEL, pressure pot (includes 19)	1
6	129571	PLUG, tube, 1.50 od	2	21	17R839	SEAL, puck, pressure pot (includes 22, 23)	1
7	17R930	FITTING, nipple, reducing, 1 x 1/2, sst	1	22	17R661	ROD, 5 in. long, 5/16-18 thread	1
8	25P575	MANIFOLD, dump	1	23	17R750	HANDLE, puck, funnel	1
9	17L622	VALVE, safety relief, 220 psi	1	24	111841	WASHER, plain 5/8	2
10	127852	FITTING, elbow, swivel, push-to-connect	1	26	15B565	VALVE, ball	1
11	17L320	GAUGE, pressure, fluid (includes 29)	1	27	17R970	LABEL, operation	1
12	129903	VALVE, ball, 2pc, sst, 3/4 in. npt	1	28	17S061	KIT, funnel edge trim, EQp	1
				29	----	LABEL, 185 psi (12.7 bar, 1.27 MPa)	1

Enclosure

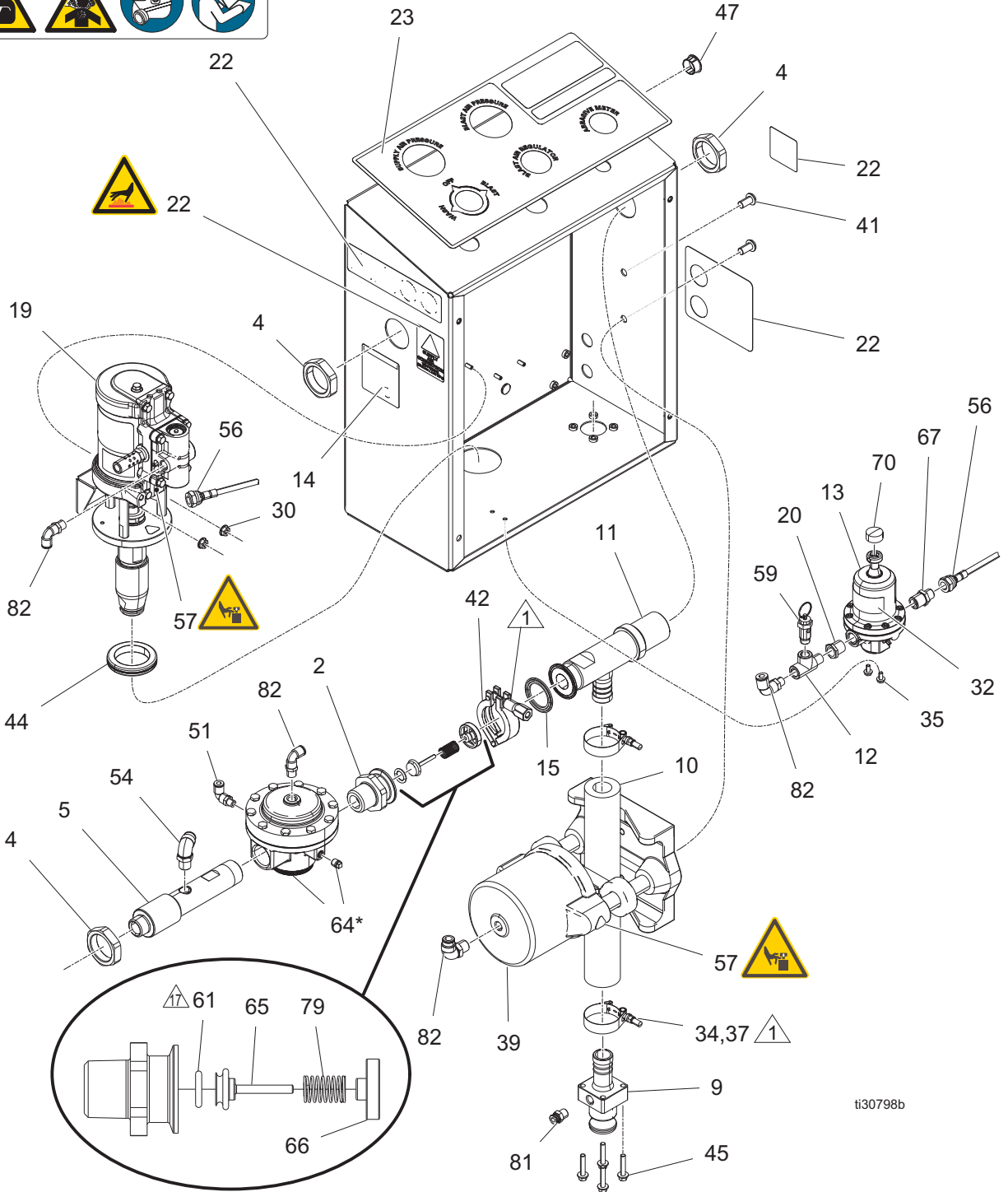

ti30798b

Enclosure Parts List

Ref.	Part	Description	Qty.	Ref.	Part	Description	Qty.
2	17R663	HOUSING, check valve, triclamp, 1 npt	1	41	128787	BOLT, button hd, 3/8-16 x 3/4, ss	2
4	17R854	NUT, 1-1/4 nps, sst	3	42	128791	CLAMP, triclamp, 1.5, hex wing nut	1
5	17R852	MANIFOLD, blast circuit, inlet	1	44	129080	GROMMET, 1-55/64 in. id, rubber, black	1
6	129574	FITTING, PTC, union y, 1/4 t	1	45	120444	SCREW, hex hd, flanged	4
9	25P574	MANIFOLD, slurry inlet, EcoQuip	1	48	128637	FITTING, PTC, straight, 1/4 MPT, 1/4 t	2
10	17R840	HOSE, pinch (includes 34, 37)	1	51	128863	FITTING, PTC, elbow, 1/4 OD, 1/8 npt	1
11a	17R853	MANIFOLD, low flow blast circuit, outlet, weld	1	54	17E554	FITTING, elbow, swivel, male, 3/8 in.	2
11b	25B051	MANIFOLD, high flow blast circuit, outlet, weld	1	56	17R497	HOSE, fluid, 1/4 npsm, 15.5 in.	1
12	106228	FITTING, tee, street	1	57▲	15F744	LABEL, warning, iso pinch hazard	1
13	17L324	REGULATOR, pressure, water, 185 psi (includes 32, 35, 70)	1	59	17L622	VALVE, safety relief, 220 psi	1
14	17R969	LABEL, instructions	1	61	C20179	PACKING, o-ring	1
15	680454	GASKET, sanitary fitting	1	64	17R849	REGULATOR, air, pilot, 1 npt	1
19	24Z932	PUMP, water, EcoQuip, 15:1, sst	1	65	17S067	PLUNGER, check valve (includes 61)	1
20	126109	FITTING, bushing, adapter, 3/8 x 1/4	1	66	17R929	GUIDE, plunger, check valve	1
22▲	17R191	LABEL, warning	1	67	166863	FITTING, nipple, reducing	1
23▲	17R192	LABEL, safety instructions	1	70	128918	CAP, vinyl, 3/4-13/16	1
30	115942	NUT, hex, flange head	2	79	128963	SPRING, 1.38 in., 2 lb/in, sst	1
32	-----	LABEL, operations	1	81	128637	FITTING, PTC, straight, 1/4npt	1
34	128642	CLAMP, hose, t-bolt, 1.75-2.00, sst	2	82	121022	FITTING, PTC, elbow, 1/4npt	10
35	128670	BOLT, flange hd, serrated, m5, sst	2				
37	128718	CAP, vinyl, 1/4-5/16	2				
39	17K052	VALVE, pinch (includes 41, 52, 57)	1				

▲ Replacement safety labels, tags, and cards are available at no cost.

Regulator

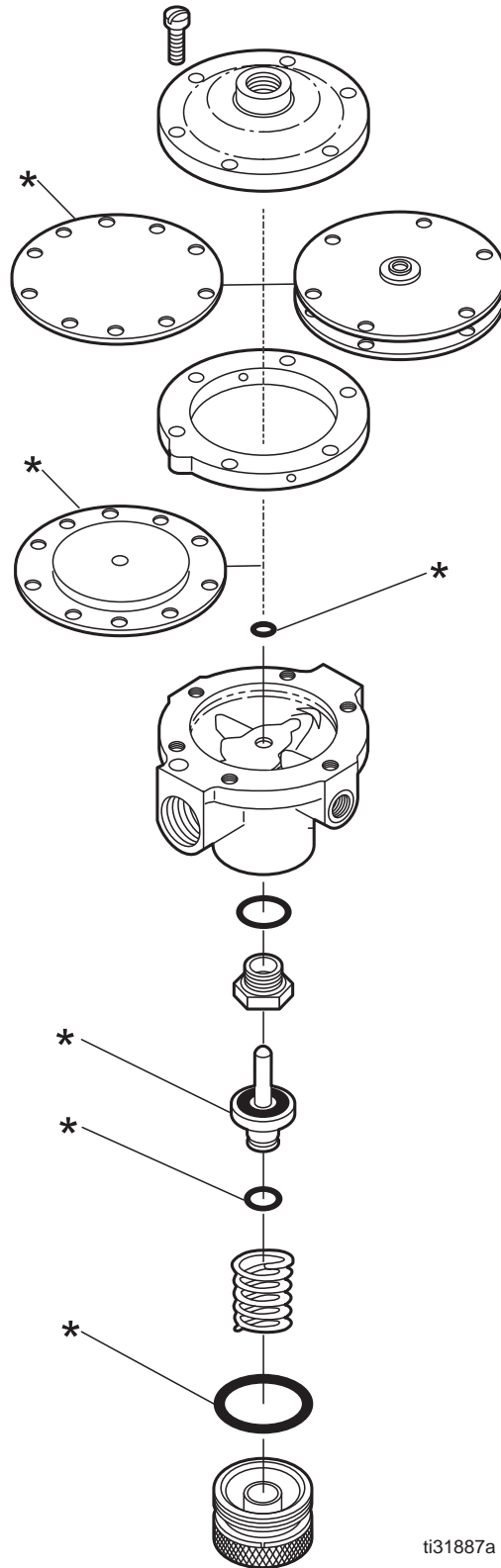

ti31887a

* Parts included in regulator kit 17R850.

Enclosure (continued)

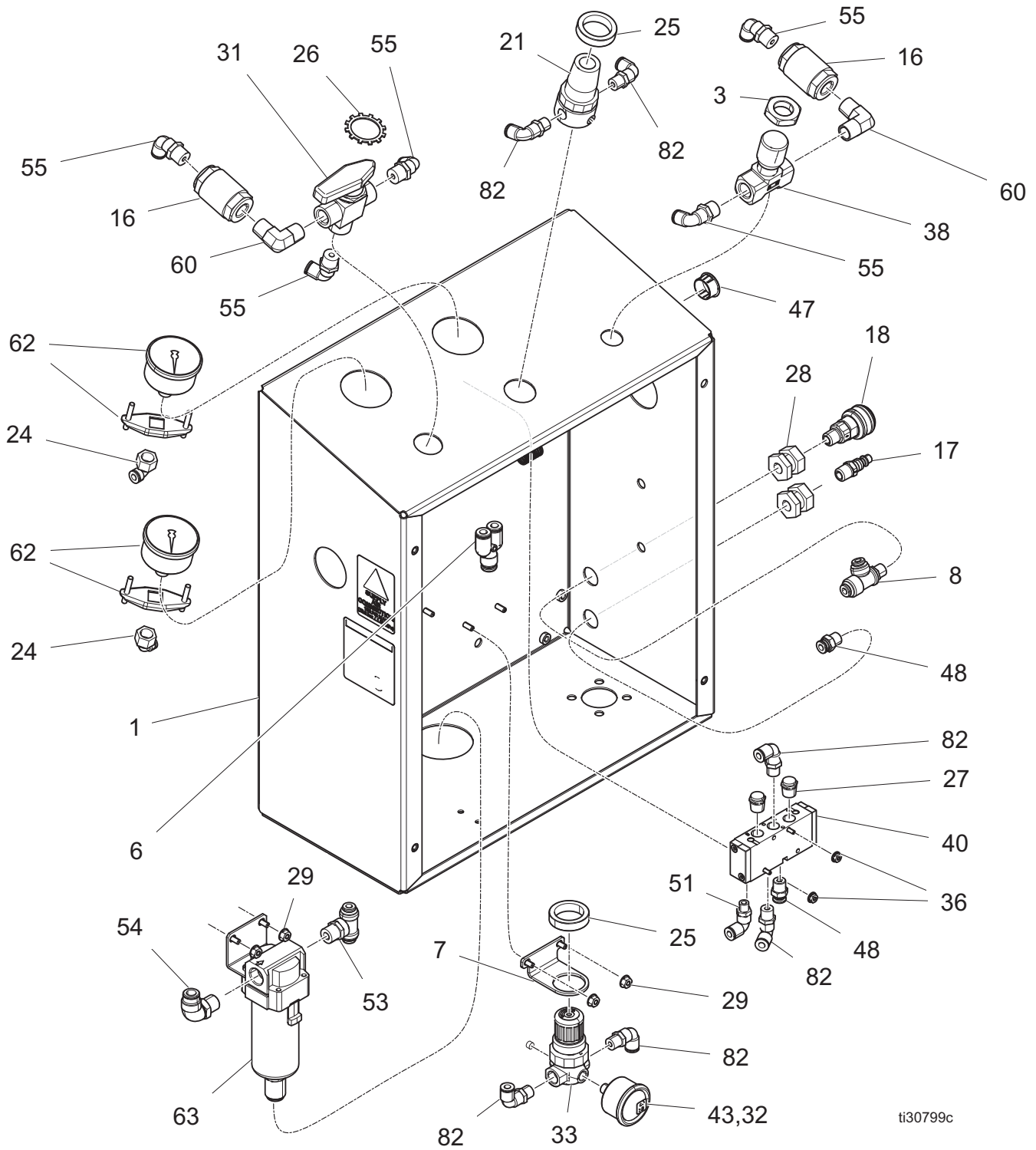

Enclosure Parts List (continued)

Ref.	Part	Description	Qty.	Ref.	Part	Description	Qty.
1	17T712	ENCLOSURE, EcoQuip, EQp	1	32	-----	LABEL, operations	1
3	17H280	NUT, M20, needle valve	1	33	17L322	KIT, regulator, pump pressure	1
7	17P287	BRACKET, air regulator	1	36	128672	NUT, serrated flange, #6-32, sst	2
8	17E553	FITTING, PTC, run tee, 1/4 mpt, 1/4 t	1	38	17K056	KIT, valve, needle	1
16	EQ1034	VALVE, check, 3/8 in., sst	2	40	17M852	KIT, valve, pilot, 4-way, pneu	1
17	129862	COUPLER, air, 1/4 qd(m), 1/4 npt(m), br	1	43	17S069	GAUGE, pressure, 1.5 in., 160 psi (includes 32)	1
18	EQ1813	COUPLER, air, 1/4qd(f), 1/4 npt(m), br	1	47	128500	PLUG, hole, snap-in	1
21	110318	REGULATOR, air, 1/4 in. npt	1	48	128637	FITTING, PTC, straight, 1/4 mpt, 1/4 t	2
24	17E556	FITTING, PTC, elbow, 1/4 fpt, 1/4 t	2	53	17E552	FITTING, PTC, branch tee, 3/8 mpt, 1/4	1
25	15K040	NUT, regulator	2	54	17E554	FITTING, elbow, swivel, male, 3/8 in.	2
26	118160	WASHER, lock, external	1	55	127852	FITTING, PTC, elbow, 3/8mpt, 1/4 t	5
27	121021	MUFFLER, 1/4 npt	2	60	15Y239	FITTING, elbow, 3/8 x 3/8 male	2
28	123390	FITTING, fitting, 1/4 npt, brs	2	62	129088	GAUGE, 2 in., U-clamp, 200 psi	2
29	127908	NUT, flange, serrated, #10-32, ss	4	63	17R847	FILTER, air, 3/8 npt	1
31	17K055	VALVE, selector, 3-way, 3/8 npt, br	1				

Blast Hoses

Pneumatic, 50 ft 24Z140 (0.5 in.), 26A075 (1.0 in.)

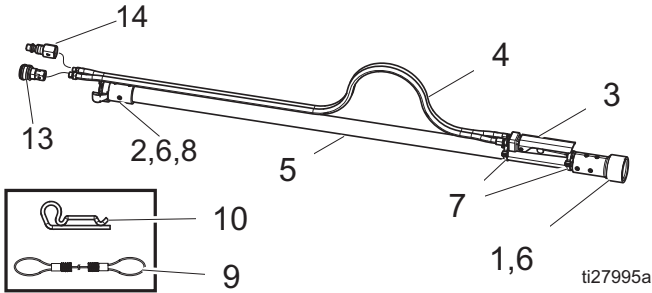

Pneumatic Extension, 50 ft 24Z141 (0.5 in.), 26A077 (1.0 in.)

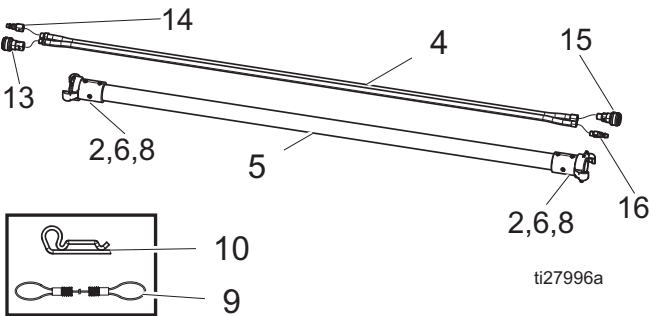

Ref.	Part	Description	Qty.
1	17R843	HOLDER, 0.50 in.	1
	17L276	HOLDER, 1.0 in.	1
2	17R844	COUPLER, 0.50 in.	1
	17L275	COUPLER, 1.0 in.	1
3	17D788	HANDLE, blast, control switch, pneumatic	1
4	24X746	HOSE, pneumatic, control, blast	1
	24X744	HOSE, pneumatic, control, extension	1
5	24Z780	HOSE, blast, 0.50 in. ID	1
	24Z781	HOSE, extension, 0.50 in. ID	1
	17L474	HOSE, blast, 1.0 in. ID	1
	17L475	HOSE, extension, 1.0 in. ID	1
6	25M474	KIT, screws, fh, sst, 8 pk	1
7	17H240	KIT, cable ties, 6 pk	1
8	17C124	GASKET, brass blast coupler	1
9	17D786	KIT, replacement, whipcheck	1
10	17D787	KIT, replacement, hairpin, hose	1
11	17L327	CONNECTOR, twist-lock, m	1
12	17L328	CONNECTOR, twist-lock, f	1
13	EQ1336	1/4 QD(f), 1/8 npt(f)	1
14	EQ1421	1/4 QD(m), 1/4 npt(f)	1
15	EQ1813	1/4 QD(f), 1/4 npt(m)	1
16	EQ1823	1/4 QD(m), 1/8 npt(m)	1

Kits and Accessories

Blast Hoses with Control Hose

Part	ID	Blast Control	Coupler 1	Coupler 2	Length	Approved
24Z140	0.5 in.	Pneumatic	Nozzle holder, aluminum	2-prong coupler, aluminum	50 ft (15 m)	Yes
24Z141			2-prong coupler, aluminum			
26A077	1.0 in.		2-prong coupler, brass	2-prong coupler, brass		
26A075			Nozzle holder, brass			

Blast Hoses without Control Hose

Part	ID	Blast Control	Coupler 1	Coupler 2	Length	Approved
17L474	1.0 in.	None	Nozzle holder, brass	2-prong coupler, brass	50 ft (15 m)	Yes
17L475			2-prong coupler, brass			
24Z780	0.5 in.		Nozzle holder, aluminum	2-prong coupler, aluminum		
24Z781			2-prong coupler, aluminum			

Blast Control Hoses

Part	Description
24X746	Blast control hose, pneumatic control line, 55 ft, ATEX approved
24X744	Blast control hose, pneumatic control line, 55 ft, extension, ATEX approved
EQ1308	Blast control switch pneumatic

Nozzles

Part	Description	Length	Thread Size
17R023	Nozzle, #3 long	3.5 in.	3/4 npsm
17R024	Nozzle, #4 long	4.7 in.	
17R025	Nozzle, #5 long	4.7 in.	
17R451	Nozzle, #5 standard	5.7 in.	50 mm Contractor Thread (2 in. 4-1/2 UNC-2A)
17K897	Nozzle, #6 standard	6.7 in.	
17J859	Nozzle, #7 standard	7.8 in.	
17K898	Nozzle, blast, high performance, #6	11.96 in.	
17J855	Nozzle, blast, high performance, #7		
17J856	Nozzle, blast, high performance, #8		

Spare Parts

Part	Description
17R833	Kit, ball valve, 2pc, 1 in. npt
17R836	Kit, water pump, 15:1, sst
17R837	Kit, o-ring, pop-up seal
17R838	Kit, inlet funnel, pressure pot
17R839	Kit, pop-up
17R843	Kit, nozzle holder, 3/4 nps
17R844	Kit, blast coupler, 3/4 nps
17R845	Kit, blast coupler, 1-1/4 nps
17R848	Kit, element, air filter
17R849	Kit, air regulator, 1 npt
17R850	Kit, repair, air regulator
17R851	Kit, gasket, 1-1/2 in. triclamp (10 pack)
187873	Gauge, pot pressure
17L622	Valve, safety relief
17R841	Strainer, suction hose, 80 mesh
131165	Kit, repair, 1 in. ball valve
25B071	KIT, water system, metal PTC replacement

Recommended Spare Parts to Have at the Job Site

Part	Description
17D786	Hose restraint / whip check
17D787	Blast hose coupler pin kit (6 pack)
17C124	Grommet, hose coupler
17L309	Gasket, abrasive hose cam lock (10 pack)
17R834	Kit, pump lower, sst
17R835	Kit, repair, pump lower
17R840	Kit, pinch hose, EQp
17R847	Kit, air filter, 3/4 npt

Accessories

Part	Description
17L119	Kit, nozzle gasket (pack of 5), 50 mm contractor thread
EQ5166	Kit, nozzle extension, 24 in. (0.6 m), 50 mm contractor thread
26A029	Kit, nozzle extension with handles, 24 in. (0.6 m) 1.25 in. ID, 50 mm contractor thread
24Z931	Kit, nozzle extension, 24 in. (0.6 m), 3/4 nps
24Z789	Kit, accessory, water dose, EQp
17J958	Kit, nozzle pressure verification tool, 50 mm contractor thread
24Z788	Kit, accessory, water tank, EQp
17R842	Kit, rinse line
17X827	Kit, poly blast cover, 100 ft

Tubing Schematic

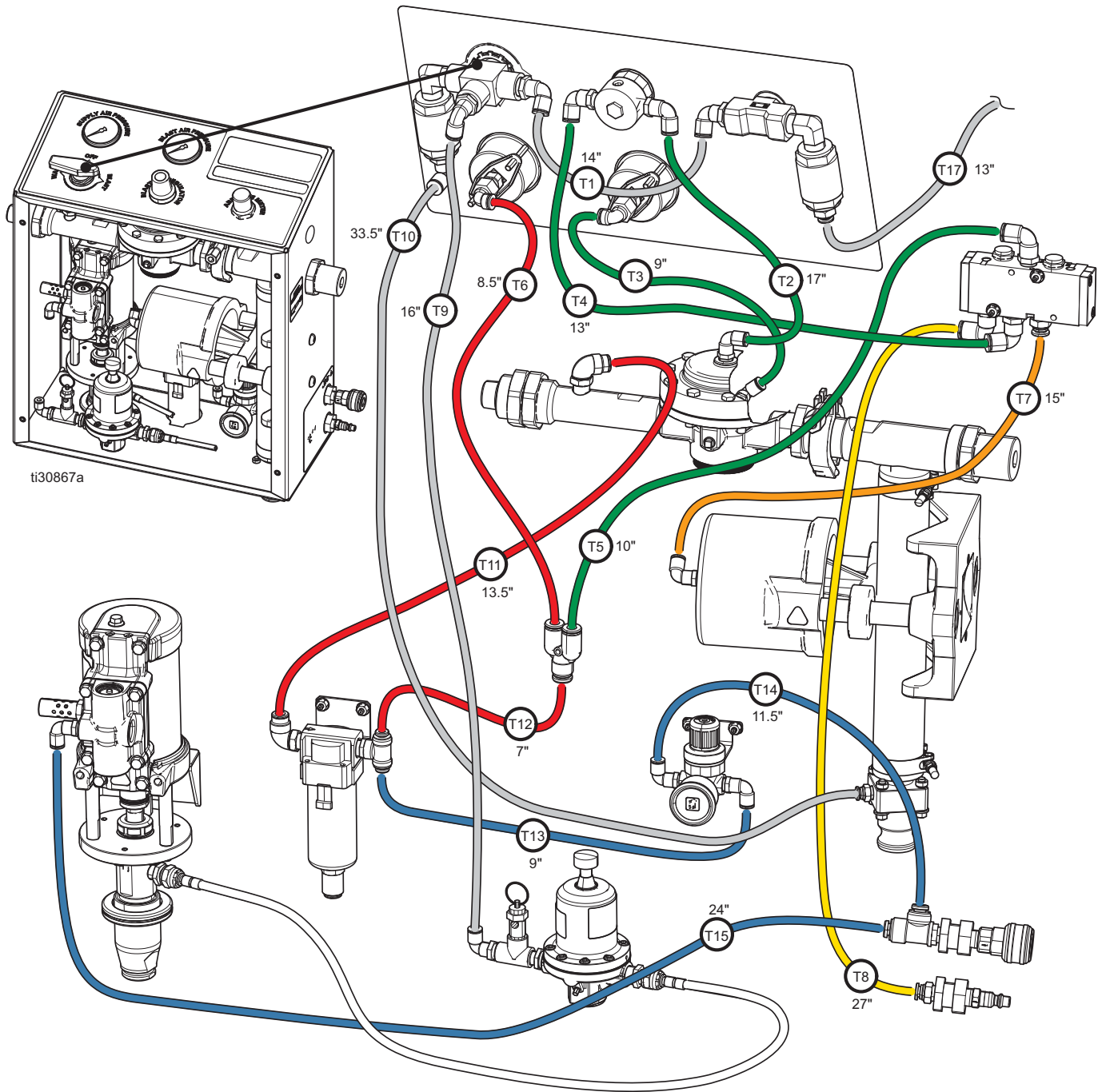

Tubing Schematic Key

Ref.	Tubing Style	Cut Length Inches (cm)
T1	Natural - 1/4 in. OD	14 in. (35.5 cm)
T2	Green - 1/4 in. OD	17 in. (43.1 cm)
T3	Green - 1/4 in. OD	9 in. (22.8 cm)
T4	Green - 1/4 in. OD	13 in. (33 cm)
T5	Green - 1/4 in. OD	10 in. (25.4 cm)
T6	Red - 1/4 in. OD	8.5 in. (21.5 cm)
T7	Orange - 1/4 in. OD	15 in. (38 cm)
T8	Yellow - 1/4 in. OD	27 in. (68.5 cm)
T9	Natural - 1/4 in. OD	16 in. (40.6 cm)
T10	Natural - 1/4 in. OD	33.5 in. (85 cm)
T11	Red - 3/8 in. OD	13.5 in. (34.2 cm)
T12	Red - 1/4 in. OD	7 in. (17.7 cm)
T13	Green - 1/4 in. OD	9 in. (22.8 cm)
T14	Green - 1/4 in. OD	11.5 in. (29.2 cm)
T15	Blue - 1/4 in. OD	24 in. (60.9 cm)
T16★	Clear - 3/8 in. OD	16 in. (40.6 cm)

★ T16 not shown - routes from the Garden Hose Connection to the Fill/Flush Valve outside of the control box.

Dimensions

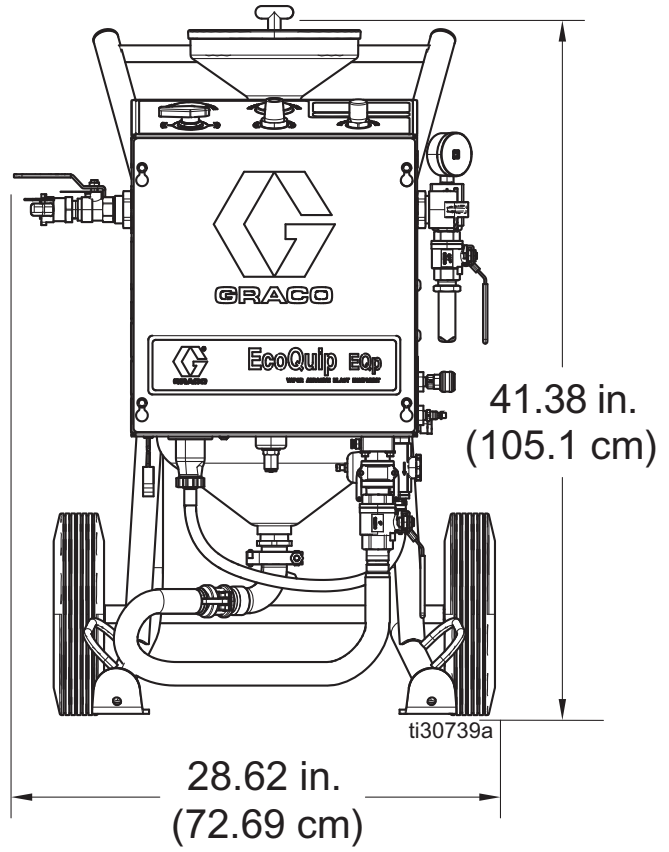
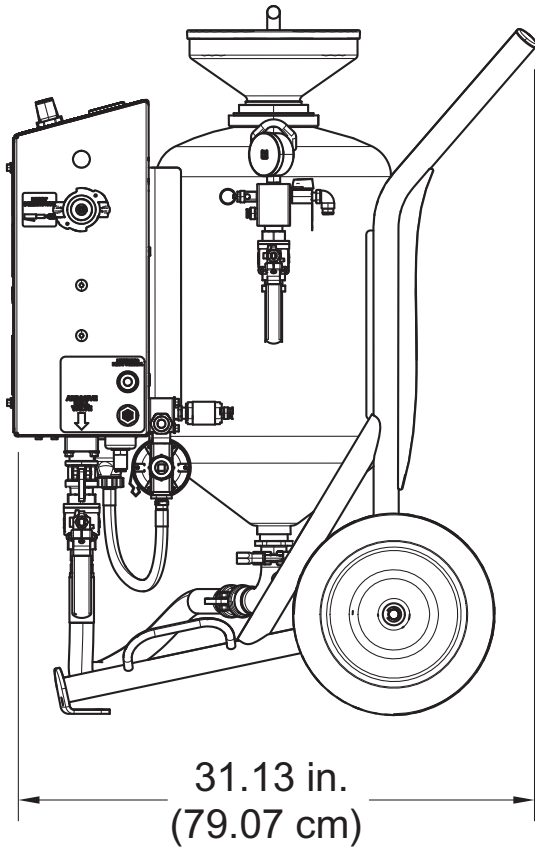

Technical Specifications

EcoQuip 2 Eqp		
	US	Metric
Maximum Air Inlet Working Pressure	150 psi	10.3 bar, 1.03 MPa
Maximum Fluid Working Pressure	185 psi	12.7 bar, 1.27 MPa
Maximum Water Supply Pressure	100 psi	6.9 bar, 0.69 MPa
Operating Temperature	35° - 110° F	1.6° - 43.3° C
Recommended Compressor Size	185 CFM	5.24 m ³ /min
Abrasive Capacity*	220 lb	100 kg
Dry Weight	220 lb	100 kg
Wet Weight	500 lb	227 kg
Pressure Pot Volume	2 cubic feet	56 liters
Air Inlet Connection**	3/4 in. Universal Crowsfoot/Chicago Fitting	3/4 in. Universal Crowsfoot/Chicago Fitting
Blast Connection***	2 Lug Claw Coupler	2 Lug Claw Coupler
Water Inlet Connection****	3/4 in. Garden Hose Connection	3/4 in. Garden Hose Connection
*Abrasive capacity and wet weight using 80 grit garnet.		
** A 3/4 in. male NPT connects to the universal claw out of the system.		
*** A 1.25 in. NPSM connects to the 2 lug claw coupler out of the system.		
**** Siphon kit is included, adapter kit or water tank kit are available as accessories.		
Air Supply Hose Minimum ID		
Less than 185 CFM compressor and 100 ft of hose	1 in. ID	25.4 mm ID
Greater than 185 CFM compressor or 100 ft of hose	1.5 in. ID	38 mm ID
Wetted Parts		
Electroless Nickel, Nylon, Brass, Stainless Steel, Coated Carbon Steel, Nickel Plated Brass, Anodized Aluminum, UHMWPE, PTFE, Nitrile, Tungsten Carbide, Acetal, Fluoroelastomer, Polyethylene, Leather, Buna, NBR, SBR, PVC.		
Sound Data		
Sound pressure level	107.2 dB(A)	
Sound power level	113.2 dB(A)	
Recorded when blasting steel with 0 garnet at a maximum blast pressure with a 1 in. blast hose, #8 nozzle, and a 375 cfm compressor set at 150 (10.3 bar, 1.03 MPa).		
Notes		
All trademarks or registered trademarks are the property of their respective owners.		

California Proposition 65

 **WARNING:** This product can expose you to chemicals known to the State of California to cause cancer and birth defects or other reproductive harm. For more information go to www.P65Warnings.ca.gov.

Graco Standard Warranty

Graco warrants all equipment referenced in this document which is manufactured by Graco and bearing its name to be free from defects in material and workmanship on the date of sale to the original purchaser for use. With the exception of any special, extended, or limited warranty published by Graco, Graco will, for a period of twelve months from the date of sale, repair or replace any part of the equipment determined by Graco to be defective. This warranty applies only when the equipment is installed, operated and maintained in accordance with Graco's written recommendations.

This warranty does not cover, and Graco shall not be liable for general wear and tear, or any malfunction, damage or wear caused by faulty installation, misapplication, abrasion, corrosion, inadequate or improper maintenance, negligence, accident, tampering, or substitution of non-Graco component parts. Nor shall Graco be liable for malfunction, damage or wear caused by the incompatibility of Graco equipment with structures, accessories, equipment or materials not supplied by Graco, or the improper design, manufacture, installation, operation or maintenance of structures, accessories, equipment or materials not supplied by Graco.

This warranty is conditioned upon the prepaid return of the equipment claimed to be defective to an authorized Graco distributor for verification of the claimed defect. If the claimed defect is verified, Graco will repair or replace free of charge any defective parts. The equipment will be returned to the original purchaser transportation prepaid. If inspection of the equipment does not disclose any defect in material or workmanship, repairs will be made at a reasonable charge, which charges may include the costs of parts, labor, and transportation.

THIS WARRANTY IS EXCLUSIVE, AND IS IN LIEU OF ANY OTHER WARRANTIES, EXPRESS OR IMPLIED, INCLUDING BUT NOT LIMITED TO WARRANTY OF MERCHANTABILITY OR WARRANTY OF FITNESS FOR A PARTICULAR PURPOSE.

Graco's sole obligation and buyer's sole remedy for any breach of warranty shall be as set forth above. The buyer agrees that no other remedy (including, but not limited to, incidental or consequential damages for lost profits, lost sales, injury to person or property, or any other incidental or consequential loss) shall be available. Any action for breach of warranty must be brought within two (2) years of the date of sale.

GRACO MAKES NO WARRANTY, AND DISCLAIMS ALL IMPLIED WARRANTIES OF MERCHANTABILITY AND FITNESS FOR A PARTICULAR PURPOSE, IN CONNECTION WITH ACCESSORIES, EQUIPMENT, MATERIALS OR COMPONENTS SOLD BUT NOT MANUFACTURED BY GRACO. These items sold, but not manufactured by Graco (such as electric motors, switches, hose, etc.), are subject to the warranty, if any, of their manufacturer. Graco will provide purchaser with reasonable assistance in making any claim for breach of these warranties.

In no event will Graco be liable for indirect, incidental, special or consequential damages resulting from Graco supplying equipment hereunder, or the furnishing, performance, or use of any products or other goods sold hereto, whether due to a breach of contract, breach of warranty, the negligence of Graco, or otherwise.

FOR GRACO CANADA CUSTOMERS

The Parties acknowledge that they have required that the present document, as well as all documents, notices and legal proceedings entered into, given or instituted pursuant hereto or relating directly or indirectly hereto, be drawn up in English. Les parties reconnaissent avoir convenu que la rédaction du présente document sera en Anglais, ainsi que tous documents, avis et procédures judiciaires exécutés, donnés ou intentés, à la suite de ou en rapport, directement ou indirectement, avec les procédures concernées.

Graco Information

For the latest information about Graco products, visit www.graco.com.

For patent information, see www.graco.com/patents.

TO PLACE AN ORDER, contact your Graco distributor or call to identify the nearest distributor.

Phone: 612-623-6921 or Toll Free: 1-800-328-0211 Fax: 612-378-3505

All written and visual data contained in this document reflects the latest product information available at the time of publication. Graco reserves the right to make changes at any time without notice.

Original instructions. This manual contains English. MM 3A4802

Graco Headquarters: Minneapolis

International Offices: Belgium, China, Japan, Korea

GRACO INC. AND SUBSIDIARIES • P.O. BOX 1441 • MINNEAPOLIS MN 55440-1441 • USA
Copyright 2018, Graco Inc. All Graco manufacturing locations are registered to ISO 9001.

www.graco.com
Revision K, October 2019