

## GH™ 130, GH200, GH230, GH300 Hydraulic Sprayers and OEM Kits

311797R

EN

---

**- Use with Architectural Coatings and Paints -**  
**For professional use only. Not approved for use in explosive atmosphere locations**

3300 psi (2.8 MPa, 228 bar) Maximum Working Pressure

List of models provided on page 2.



**IMPORTANT SAFETY INSTRUCTIONS.**

Read all warnings and instructions in this manual. Save these instructions. Contact Graco Customer Service, your local Graco distributor or our website: [www.graco.com](http://www.graco.com), to obtain a manual in your language.

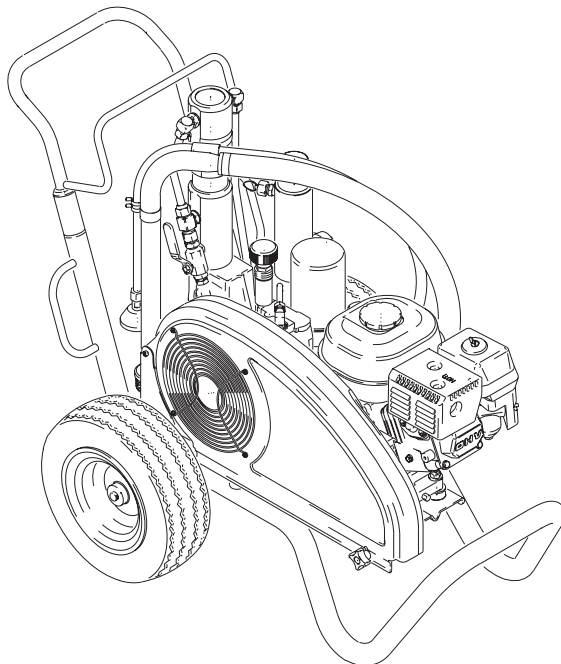



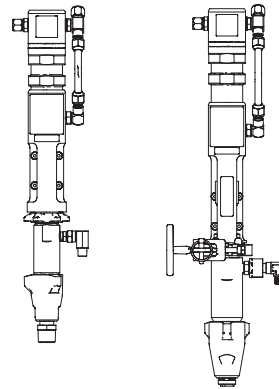



**Hydraulic Sprayers**



**OEM Kits**

t15380b

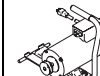
# Sprayer Models

	 GH130	 GH200	 GH230	 GH300	 120 Vac 60 Hz	 ETL/CSA/UL 120 Vac 60 Hz	
253957	✓						✓
253959	✓				✓		✓
253980	✓					✓	✓
253962		✓					✓
253963		✓			✓		✓
253981		✓				✓	✓
255095		✓					✓
253965			✓				✓
253966			✓		✓		✓
253982			✓			✓	✓
253968				✓			✓

## Electric Motor Kit Options





Kit Number	Sprayer Model	Description
288474	GH130	120VAC, 60Hz, 20A, CAS/UL approved
288473	GH130	120VAC, 60Hz, 15A
248950	GH200/GH230	120VAC, 60Hz, 20A, CSA/UL approved
248949	GH200/GH230	120 VAC, 60Hz, 15A
248946	EH200/HD1200	240VAC, 50Hz, 13.4A

## OEM Kits







Kit Number	OEM Model	Description
24W297	GH130 OEM	3300 psi (22.8 MPa, 227 bar) Maximum Working Pressure (Material Working psi)
24W298	GH200 OEM	3300 psi (22.8 MPa, 227 bar) Maximum Working Pressure (Material Working psi)
24W299	GH230/300 OEM	3300 psi (22.8 MPa, 227 bar) Maximum Working Pressure (Material Working psi)

# Warnings

The following Warnings are for the setup, use, grounding, maintenance and repair of this equipment. The exclamation point symbol alerts you to a general warning and the hazard symbols refer to procedure-specific risks. Refer back to these Warnings. Additional, product-specific warnings may be found throughout the body of this manual where applicable.

 <b>WARNING</b>	
	<p><b>FIRE AND EXPLOSION HAZARD</b></p> <p>Flammable fumes, such as solvent and paint fumes, in <b>work area</b> can ignite or explode. To help prevent fire and explosion:</p> <ul style="list-style-type: none"> <li>• Use equipment only in well ventilated area.</li> <li>• Eliminate all ignition sources; such as pilot lights, cigarettes, portable electric lamps, and plastic drop cloths (potential static arc).</li> <li>• Keep work area free of debris, including solvent, rags and gasoline.</li> <li>• Do not plug or unplug power cords, or turn power or light switches on or off when flammable fumes are present.</li> <li>• Ground all equipment in the work area. See <b>Grounding</b> instructions.</li> <li>• Use only grounded hoses.</li> <li>• Hold gun firmly to side of grounded pail when triggering into pail.</li> <li>• If there is static sparking or you feel a shock, <b>stop operation immediately</b>. Do not use equipment until you identify and correct the problem.</li> <li>• Keep a working fire extinguisher in the work area.</li> </ul>
	<p><b>SKIN INJECTION HAZARD</b></p> <p>High-pressure fluid from gun, hose leaks, or ruptured components will pierce skin. This may look like just a cut, but it is a serious injury that can result in amputation. <b>Get immediate surgical treatment.</b></p> <ul style="list-style-type: none"> <li>• Do not point gun at anyone or at any part of the body.</li> <li>• Do not put your hand over the spray tip.</li> <li>• Do not stop or deflect leaks with your hand, body, glove, or rag.</li> <li>• Do not spray without tip guard and trigger guard installed.</li> <li>• Engage trigger lock when not spraying.</li> <li>• Follow <b>Pressure Relief Procedure</b> in this manual, when you stop spraying and before cleaning, checking, or servicing equipment.</li> </ul>
	<p><b>ELECTRIC SHOCK HAZARD</b></p> <p>Improper grounding, setup, or usage of the system can cause electric shock.</p> <ul style="list-style-type: none"> <li>• Turn off and disconnect power cord before servicing equipment.</li> <li>• Use only grounded electrical outlets.</li> <li>• Use only 3-wire extension cords.</li> <li>• Ensure ground prongs are intact on sprayer and extension cords.</li> <li>• Do not expose to rain. Store indoors.</li> </ul>

# ⚠️ WARNING

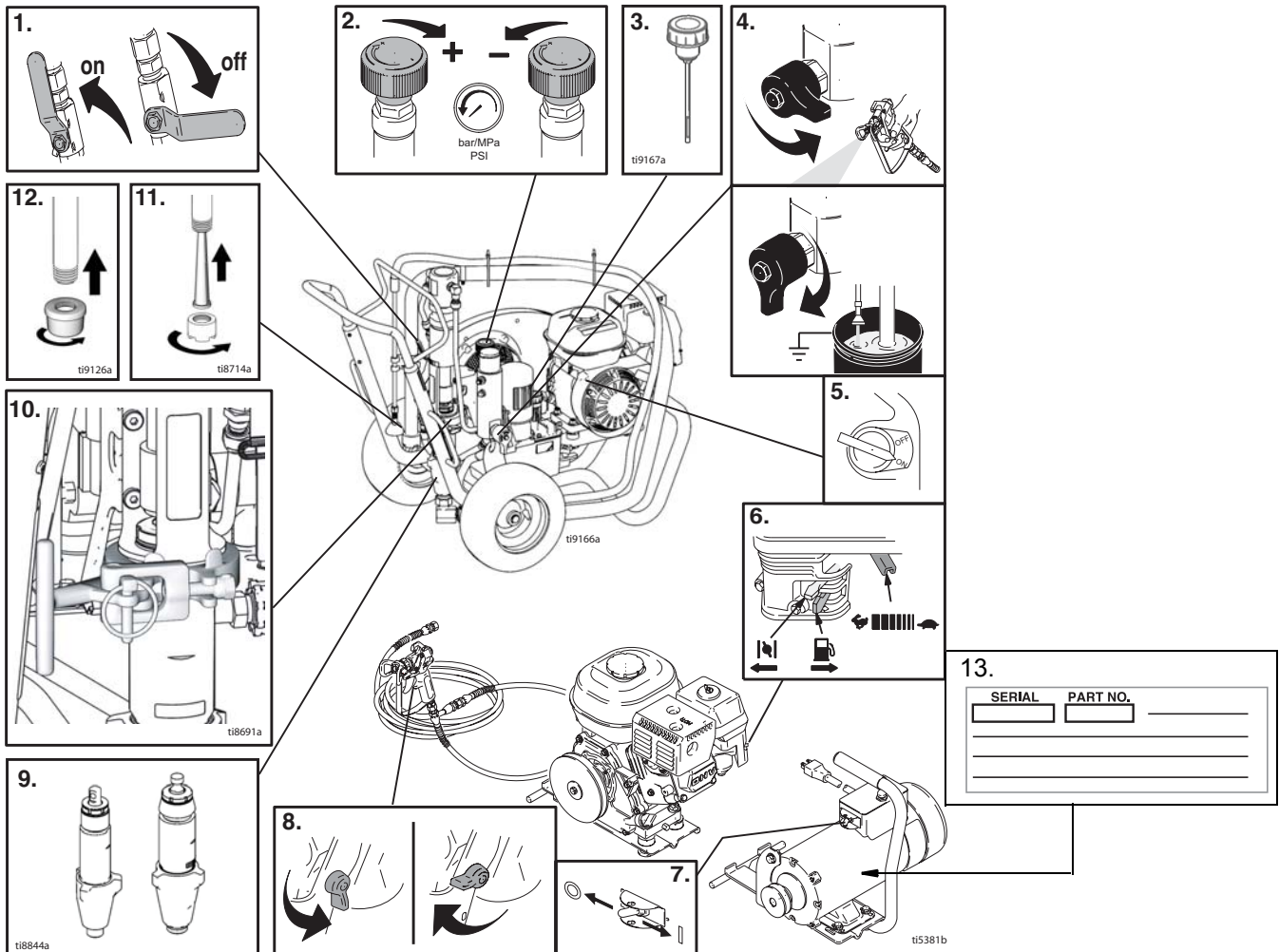

	<p><b>MOVING PARTS HAZARD</b> Moving parts can pinch or amputate fingers and other body parts.</p> <ul style="list-style-type: none"> <li>• Keep clear of moving parts.</li> <li>• Do not operate equipment with protective guards or covers removed.</li> <li>• Pressurized equipment can start without warning. Before checking, moving, or servicing equipment, follow the <b>Pressure Relief Procedure</b> in this manual. Disconnect power or air supply.</li> </ul>
	<p><b>PRESSURIZED ALUMINUM PARTS HAZARD</b> Do not use 1,1,1-trichloroethane, methylene chloride, other halogenated hydrocarbon solvents or fluids containing such solvents in pressurized aluminum equipment. Such use can cause serious chemical reaction and equipment rupture, and result in death, serious injury, and property damage.</p>
	<p><b>SUCTION HAZARD</b> Never place hands near the pump fluid inlet when pump is operating or pressurized. Powerful suction could cause serious injury.</p>
	<p><b>CARBON MONOXIDE HAZARD</b> Exhaust contains poisonous carbon monoxide, which is colorless and odorless. Breathing carbon monoxide can cause death. Do not operate in an enclosed area.</p>
	<p><b>TOXIC FLUID OR FUMES HAZARD</b> Toxic fluids or fumes can cause serious injury or death if splashed in the eyes or on skin, inhaled, or swallowed.</p> <ul style="list-style-type: none"> <li>• Read MSDS's to know the specific hazards of the fluids you are using.</li> <li>• Store hazardous fluid in approved containers, and dispose of it according to applicable guidelines.</li> </ul>
	<p><b>BURN HAZARD</b> Equipment surfaces and fluid that's heated can become very hot during operation. To avoid severe burns, do not touch hot fluid or equipment. Wait until equipment/fluid has cooled completely.</p>
	<p><b>PERSONAL PROTECTIVE EQUIPMENT</b> You must wear appropriate protective equipment when operating, servicing, or when in the operating area of the equipment to help protect you from serious injury, including eye injury, inhalation of toxic fumes, burns, and hearing loss. This equipment includes but is not limited to:</p> <ul style="list-style-type: none"> <li>• Protective eyewear</li> <li>• Clothing and respirator as recommended by the fluid and solvent manufacturer</li> <li>• Gloves</li> <li>• Hearing protection</li> </ul>
	<p><b>CALIFORNIA PROPOSITION 65</b> This product contains a chemical known to the State of California to cause cancer, birth defects or other reproductive harm. Wash hands after handling.</p>

# Component Identification





Item No.	Component
1	Hydraulic pump valve
2	Pressure control
3	Hydraulic Oil Cap
4	Drain valve
5	Engine ON/OFF switch
6	Engine controls
7	Electric motor On/Off Switch
8	Gun trigger Lock
9	Displacement pump
10	ProConnect™
11	Inlet strainer (standard)
12	Inlet strainer (option)
13	Serial number tag

# General Repair Information

						
<p>To reduce risk of serious injury, do not touch moving parts with fingers or tools while testing repair. Shut off sprayer when repairing. Install all covers, gaskets, screws and washers before operating sprayer</p>						

- 1 Keep all screws, nuts, washers, gaskets, and electrical fittings removed during repair procedures. These parts are not normally provided with replacement assemblies.
- 2 Test repair after problem is corrected.
- 3 If sprayer does not operate properly, review repair procedure to verify procedure was done correctly. If necessary, see Troubleshooting Guide, page 7, for other possible solutions.

						
---	---	---	--	--	--	--

- 4 Install belt guard before operation of sprayer and replace if damaged. Belt guard reduces risk of pinching and loss of fingers; see preceding WARNING.

## Grounding

Ground sprayer with grounding clamp to earth ground for safe sprayer operation when using solvent-based materials. Fig. 1.

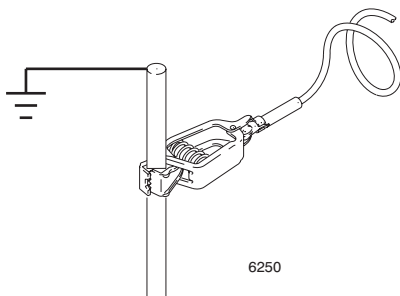
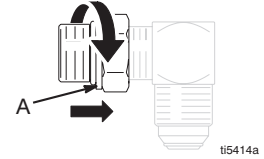

FIG. 1

## SAE O-Ring Installation

- 1 Unscrew lock nut to touch fitting.

- 2 Lubricate o-ring (A).



- 3 Screw in fitting hand tight.

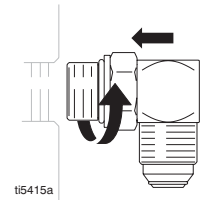

- 4 Unscrew fitting until oriented properly.

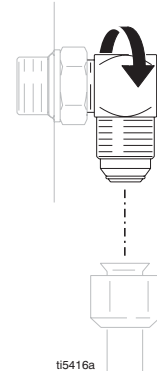

- 5 Tighten lock nut to indicated torque. (Make sure washer is seated properly without pinching o-ring).

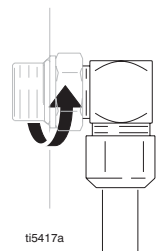

# Maintenance

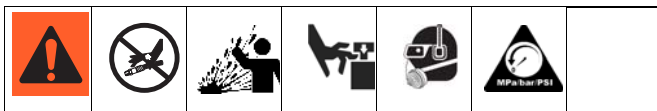

## Pressure Relief Procedure

This equipment stays pressurized until pressure is manually relieved. To help prevent serious injury from pressurized fluid, such as skin injection, splashing fluid and moving parts, follow the Pressure Relief Procedure when you stop spraying and before cleaning, checking, or servicing the equipment

- 1 Engage trigger lock.
- 2 Turn engine ON/OFF switch to OFF. Close the bleed-type master air valve.
- 3 Disengage the trigger lock.
- 4 Hold a metal part of the gun firmly to a grounded metal pail. Trigger the gun to relieve pressure.
- 5 Engage the trigger lock.
- 6 Open all fluid drain valves in the system, having a waste container ready to catch drainage. Leave drain valve(s) open until you are ready to spray again.
- 7 *If you suspect the spray tip or hose is clogged or that pressure has not been fully relieved:*
  - a. VERY SLOWLY loosen tip guard retaining nut or hose end coupling to relieve pressure gradually.
  - b. Loosen nut or coupling completely.
  - c. Clear hose or tip obstruction.

### NOTICE

For detailed engine maintenance and specifications, refer to separate Honda Engines Owner's Manual, supplied.

**DAILY:** Check engine oil level and fill as necessary.

**DAILY:** Check hydraulic oil level and fill as necessary.

**DAILY:** Check hose for wear and damage.

**DAILY:** Check gun safety for proper operation.

**DAILY:** Check pressure drain valve for proper operation.

**DAILY:** Check and fill the gas tank.

**DAILY:** Check that displacement pump is tight.

**DAILY:** Check level of Throat Seal Liquid (TSL) in displacement pump packing nut. Fill nut, if necessary. Keep TSL in nut to help prevent fluid buildup on piston rod and premature wear of packings and pump corrosion.

### AFTER THE FIRST 20 HOURS OF OPERATION:

Drain engine oil and refill with clean oil. Reference Honda Engines Owner's Manual for correct oil viscosity.

**WEEKLY:** Remove engine air filter cover and clean element. Replace element, if necessary. If operating in an unusually dusty environment: check filter daily and replace, if necessary.

Replacement elements can be purchased from your local HONDA dealer.

**WEEKLY/DAILY:** Remove any debris or media from hydraulic rod.

### AFTER EACH 100 HOURS OF OPERATION:

Change engine oil. Reference Honda Engines Owner's Manual for correct oil viscosity.

### SEMI-ANNUALLY:

Check belt wear, page 10; replace if necessary.

### YEARLY OR 2000 HOURS:

Replace hydraulic oil and filter with Graco hydraulic oil 169236 (5 gallon/20 liter) or 207428 (1 gallon/3.8 liter) and filter 116909.

Replace belt.

**SPARK PLUG:** Use only BPR6ES (NGK) or W20EPR-U (NIPPONDENSO) plug. Gap plug to 0.028 to 0.031 in. (0.7 to 0.8 mm). Use spark plug wrench when installing and removing plug.

# Troubleshooting

PROBLEM	CAUSE	SOLUTION
Gas engine pulls hard (won't start)	Hydraulic pressure is too high	Turn hydraulic pressure knob counter clockwise to lowest setting.
Gas engine does not start	Switch OFF, low oil, no gasoline	Consult engine manual, supplied.
Gas engine doesn't work properly	Faulty engine	Consult engine manual, supplied.
	Elevation	Refer to Engine Repair Kit. 4.0 hp - 288678 / 5.5 hp - 248943 / 6/5 hp - 248944 / 9.0 hp - 248945
Gas engine operates, but displacement pump doesn't operate	Hydraulic pump valve is OFF	Set hydraulic pump valve ON.
	Pressure setting too low	Increase pressure.
	Displacement pump outlet filter (if used) is dirty or clogged	Clean the filter.
	Tip or tip filter (if used) is clogged	Remove tip and/or filter and clean.
	Hydraulic fluid too low	Shut off sprayer. Add fluid*.
	Belt worn or broken or off	Replace, page 12.
	Hydraulic pump worn or damaged	Bring sprayer to Graco distributor for repair.
	Dried paint seized paint pump rod	Service pump. See manual 311845.
	Hydraulic motor not shifting	Set pump valve OFF. Turn pressure down. Turn engine OFF. Pry rod up or down until hydraulic motor shifts .
Displacement pump operates, but output is low on upstroke	Piston ball check not seating properly	Service piston ball check. See manual 311845.
	Piston packings worn or damaged	Replace packings. See manual 311845.
Displacement pump operates but output is low on downstroke and/or on both strokes	Piston packings worn or damaged	Tighten packing nut or replace packings. See manual 311845.
	Intake valve ball check not seating properly	Service intake valve ball check. See manual 311845.
	Suction tube air leak	
Paint leaks and runs over side of wetcup	Loosen wet-cup	Tighten wet-cup enough to stop leakage.
	Throat packings worn or damaged	Replace packings. See manual 311845.
Excessive leakage around hydraulic motor piston rod wiper	Piston rod seal worn or damaged	Replace these parts.
Fluid delivery is low	Pressure setting too low	Increase pressure.
	Displacement pump outlet filter (if used) is dirty or clogged	Clean filter.
	Intake line to pump inlet is not tight	Tighten.
	Hydraulic motor is worn or damaged	Bring sprayer to Graco distributor for repair.
	Large pressure drop in fluid hose	Use larger diameter or shorter hose.
The sprayer overheats	Paint buildup on hydraulic components	Clean.
Spitting from gun	Air in fluid pump or hose	Check for loose connections on siphon assembly, tighten, then reprime pump.
	Loose intake suction	Tighten.
	Fluid supply is low or empty	Refill supply container.
Excessive hydraulic pump noise	Low hydraulic fluid level	Turn sprayer OFF. Add fluid*.
Electric motor does not operate	Power switch is not ON	Turn power switch to ON.
	Tripped circuit breaker	Check circuit breaker at power source. Reset motor switch.
*Check hydraulic fluid level often. Do not allow it to become too low. Use only Graco approved hydraulic fluid.		





# Hydraulic Pump

(Figure 2)

## Removal

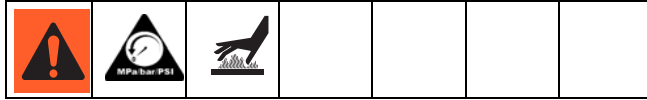

Let hydraulic system cool before beginning service.

- 1 **Relieve pressure**, page 7.
- 2 Place drip pan or rags under sprayer to catch hydraulic oil that leaks out during repair.
- 3 Remove drain plug (2) and oil filter (227) and allow hydraulic oil to drain.
- 4 Fig. 2. Disconnect suction tube (114).
- 5 Disconnect pump (111), page 15.
- 6 Remove screw (172), nut (173) and belt guard (117).
- 7 Raise motor and remove belt (44).
- 8 Remove two set screws (176) and fan pulley (96).
- 9 Remove case drain tube (225).
- 10 Remove elbow (221).
- 11 Remove tube (276) from elbow (226). Remove elbow (226) from hydraulic pump (220).
- 12 Remove eight screws (212) reservoir cover (209) filter assembly (206) and gasket (203).
- 13 Remove four screws (277) and hydraulic pump (220) from reservoir cover (209).

## Installation

- 1 Install hydraulic pump (220) to reservoir cover (209) with four screws (277); torque 90-110 in-lb (10.1-12.4 N·m).
- 2 Install gasket (203) and reservoir cover (209) with eight screws (212); torque 110+/-5 in-lb (12.4 +/- 0.5 N·m).
- 3 Install elbow (226) in hydraulic pump (220). Install elbow (226) in tube (276). Torque to 25 ft-lb (33.9 N·m).
- 4 Install elbow (221); torque to 15 ft-lb (20.3 N·m).
- 5 Install case drain tube (225); torque to 15 ft-lb (20.3 N·m).
- 6 Install fan pulley (96) with two set screws (176).
- 7 Raise motor and install belt (44).
- 8 Install belt guard (117) with screw (172) and nut (173).
- 9 Connect pump (111), page 15.
- 10 Fig. 2. Connect suction tube (114).
- 11 Install drain plug (2); torque to 110 in-lb (12.4 N·m). Install oil filter (227); tighten 3/4 turn after gasket contacts base. Fill hydraulic pump with Graco hydraulic oil, page 6, through elbow (221) port until full. Fill reservoir with remaining hydraulic oil.
- 12 Start up and allow pump to operate at low pressure for approximately 5 minutes to purge all air.
- 13 Check oil hydraulic oil and top off, if required.



# Fan Belt

(Figure 3)

## Removal

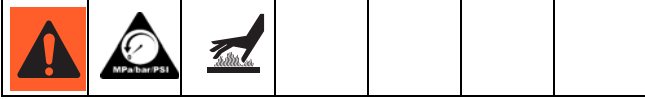

- 1 **Relieve pressure**, page 7.
- 2 Loosen belt guard knob (55).
- 3 Rotate belt guard (117) up.
- 4 Lift engine (119) up to remove tension on belt (44).
- 5 Remove belt from pulley (43) and fan pulley (96).

## Installation

- 1 Thread belt (44) around drive pulley (43) and fan pulley (96).
- 2 Let engine (119) down to put tension on belt.
- 3 Rotate belt guard (117) down.
- 4 Tighten belt guard knob (55).

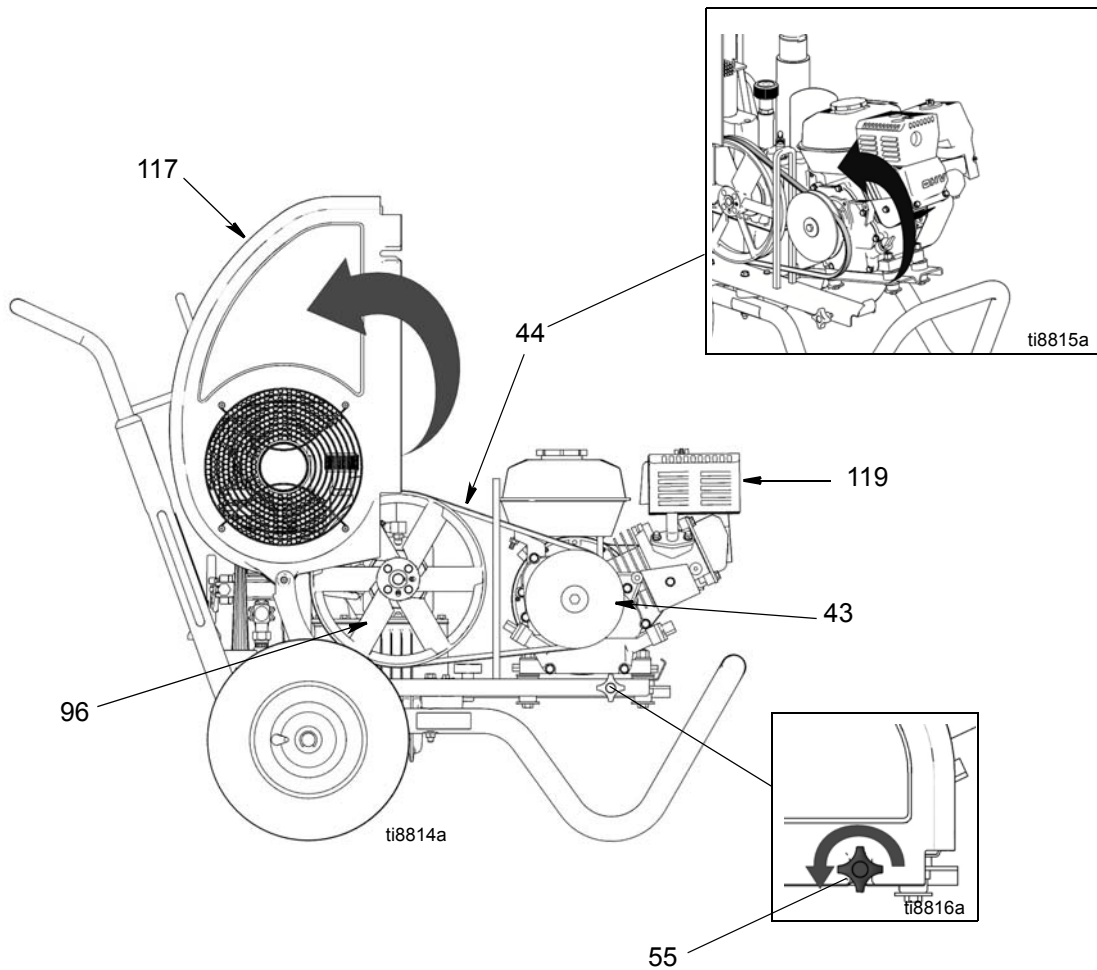

FIG. 3

# Engine

(Figure 4)

## Removal

**NOTE:** All service to the engine must be performed by an authorized HONDA dealer.

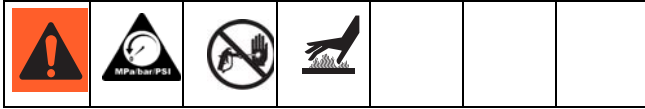

- 1 **Relieve pressure**, page 7.
- 2 Remove **Fan Belt**, page 10.
- 3 Loosen motor nut (205). Swing motor retainer bracket (204) out.
- 4 Remove engine (119) and rocker plate (99) from sprayer.
- 5 Remove four screws (23), washers (7) and nuts (24) and remove rocker plate (99), dampeners (153) and washers (154) from engine (119).

## Installation

- 1 Install rocker plate (99), dampeners (153) and washers (154) on engine (119) with four screws (23), washers (7) and nuts (24); torque to 125 in-lb (14.1 N·m).
- 2 Install engine and rocker plate (99) on sprayer.
- 3 Swing motor retainer bracket (204) in. Tighten motor nut (205).
- 4 Install **Fan Belt**, page 10.

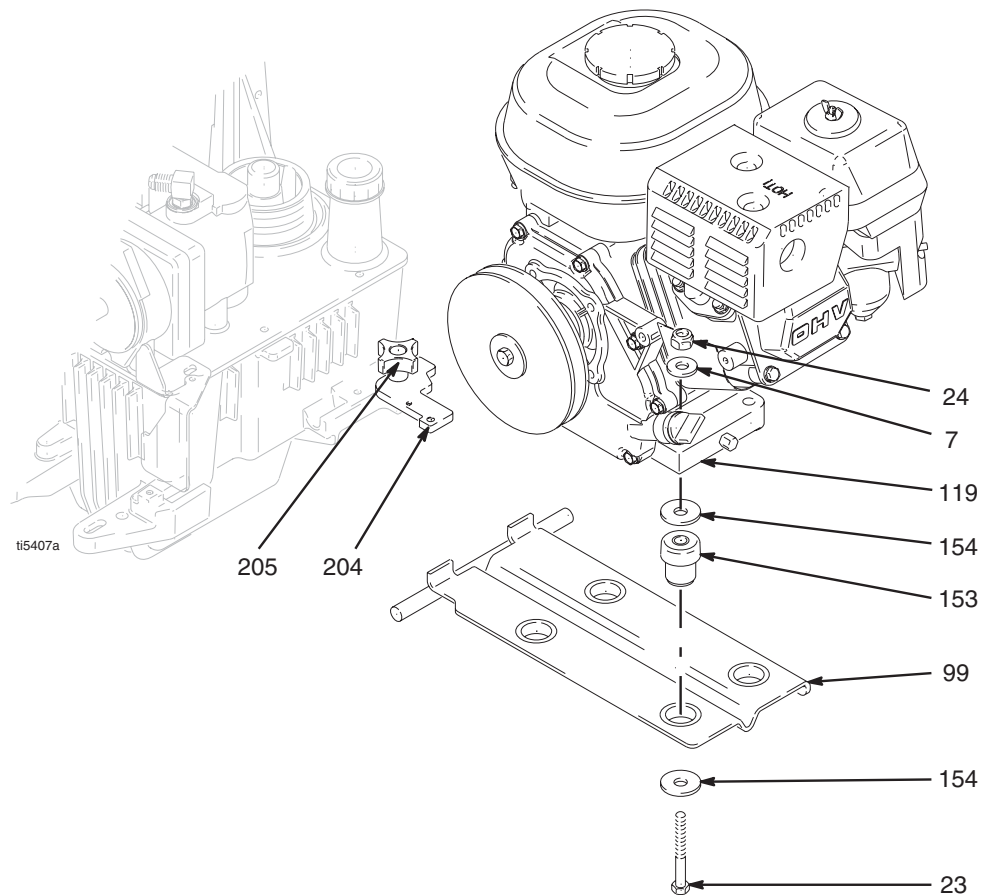
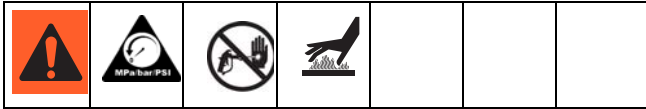

FIG. 4

# Hydraulic Motor Rebuild

(Figure 5)

## Removal



- 1 Relieve pressure, page 7.
- 2 Place drip pan or rags under sprayer to catch hydraulic oil that leaks out during repair.
- 3 GH130 Models:  
- Follow Steps 2-5 of pump removal instructions, page 17.  
  
GH200, GH230, GH300 Models:  
- Follow Steps 4-8 of pump removal instructions, page 18.
- 4 Remove hydraulic lines (271, 288) from fittings (266) at top left and right side of hydraulic motor.
- 5 Loosen jam nut (264).
- 6 Unscrew and remove hydraulic motor cap (265).
- 7 Slide piston rod/hydraulic motor cap assembly (A) from hydraulic motor cylinder (263).

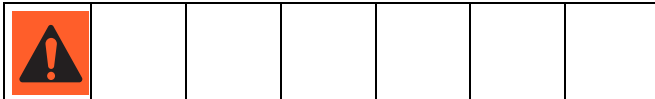

### FLYING PARTS HAZARD

Detent spring has high energy potential. If detent spring is released without due care detent spring and balls could fly into the eyes of the disassembler. Wear safety glasses when removing or installing detent spring and balls. Failure to wear safety glasses when removing detent spring could result in eye injury or blindness.

## Installation



### FLYING PARTS HAZARD

- 1 Slide piston rod assembly into hydraulic motor cylinder (263).
- 2 Screw down hydraulic motor cap (265). Unscrew hydraulic motor cap until inlet and outlet align with hydraulic line fittings and test hole in hydraulic motor cap points toward belt guard (117).
- 3 Torque jam nut (264) against hydraulic motor cap (265) to 150 ft-lb (17 N•m).
- 4 Fig. 5. Install hydraulic lines (271, 288) to fittings (266) to top left and right side of hydraulic motor; torque to 40 ft-lb (54.2 N•m).
- 5 GH130 Models:  
- Follow Step 2 of pump installation instructions, page 17.  
  
GH200, GH230, GH300 Models:  
- Follow Steps 2-7 of pump installation instructions, page 19.
- 6 Start engine and operate pump for 30 seconds. Turn engine OFF. Check hydraulic oil level and fill with Graco hydraulic oil, page 6.

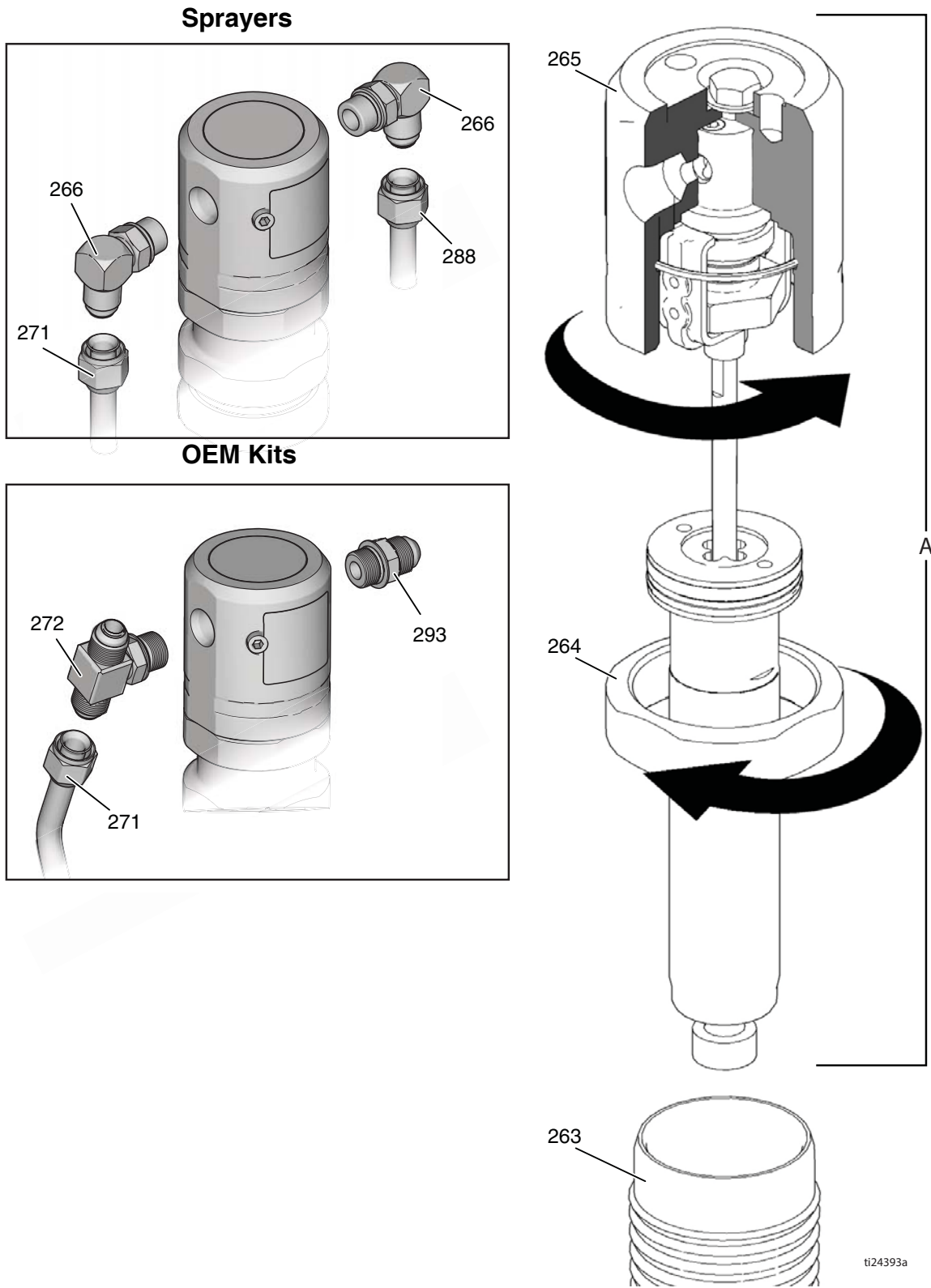
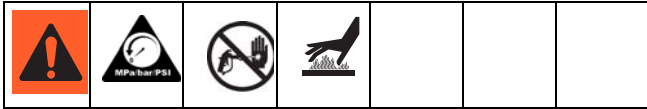

FIG. 5

# Hydraulic Oil/Filter Change

(Figure 6)

## Removal



- 1 **Relieve pressure**, page 7.
- 2 Place drip pan or rags under sprayer to catch hydraulic oil that drains out.
- 3 Remove drain plug (2). page 26. Allow hydraulic oil to drain.
- 4 Unscrew filter (227) slowly - oil runs into groove and drains out rear.

## Installation

- 1 Install drain plug (2) and oil filter (227). Tighten oil filter 3/4 turn after gasket contacts base.
- 2 Fill with five quarts of Graco hydraulic oil 169236 (5 gallon/20 liter) or 207428 (1 gallon/3.8 liter).
- 3 Check oil level.

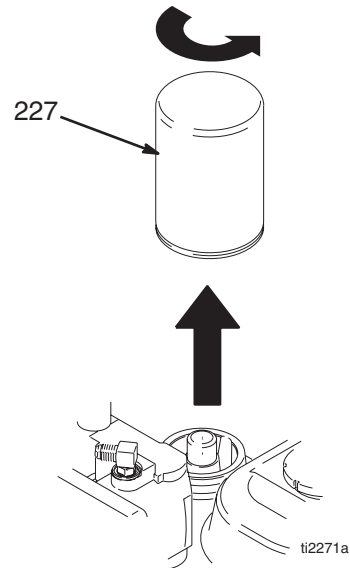

FIG. 6



# Displacement Pump

GH130 Only

(Figures 7-12)

See manual 311845 for pump repair instructions

## Removal

- 1 Flush pump.
- 2 **Relieve pressure**, page 7.



- 3 (Fig. 7) Remove suction tube (114) and paint hose (63) (remove at swivel end).

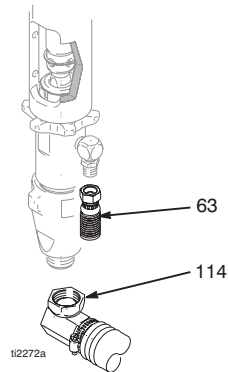

FIG. 7

- 4 (Fig. 8) Push retaining ring (120) up; push out pin (92).

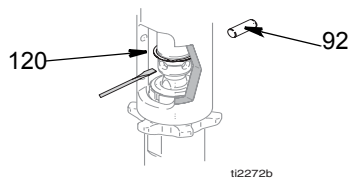

FIG. 8

- 5 (Fig. 9). Loosen jam nut (86). Unscrew pump (111).

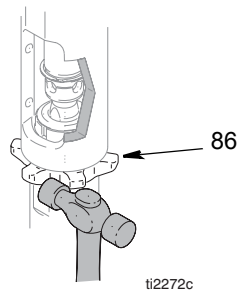
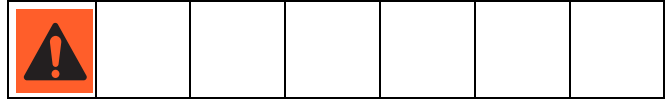

FIG. 9

## Installation



If pin (92) works loose, parts could break off and project through the air, resulting in serious injury or property damage. Make sure pin is properly installed.

### CAUTION

If the pump jam nut (86) loosens during operation, the threads of the bearing housing and drive train will be damaged. Tighten jam nut (86) as specified.

- 1 (Fig. 10) Screw jam nut (86) to bottom of pump (111) threads. Screw pump (111) completely into manifold. Unscrew pump (111) from manifold until pump outlet aligns with hose. Hand tighten jam nut (86), then tap 1/8 to 1/4 turn with hammer or torque to 75 ft-lb (101 N·m).

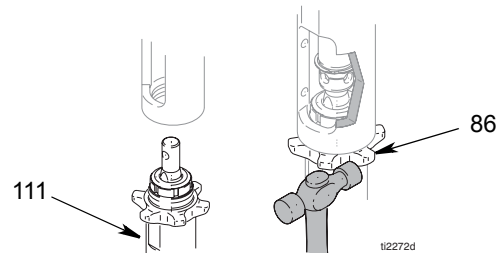

FIG. 10

- 2 (Fig. 11) Slowly pull engine starter rope until pump rod pin hole is aligned with hydraulic rod hole. Fig. 8. Push pin (92) into hole. Push retaining ring (120) into groove.

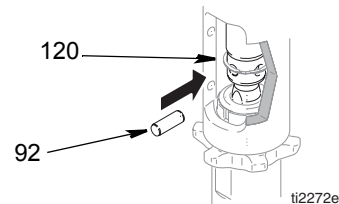

FIG. 11

- 3 (Fig. 12) Fill packing nut with Graco TSL.

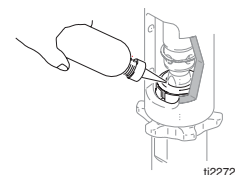

FIG. 12

# Displacement Pump ProConnect

GH200/230/300 Only

(Figures 13-27)

See pump manual 311845 for pump repair.

## Removal

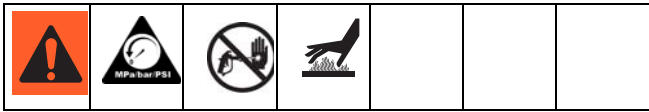

- 1 Flush pump.
- 2 Relieve pressure, page 7.
- 3 (Fig. 13) Remove suction hose (114).

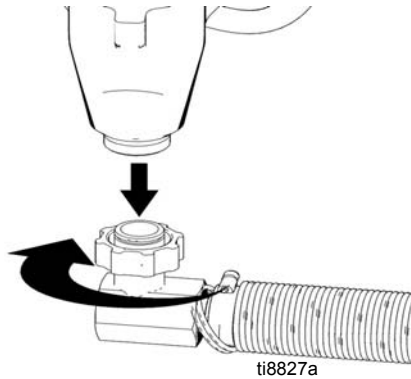

FIG. 13

- 4 (Fig. 14) Remove paint hose fitting (190) and paint hose (63) from pump fitting.

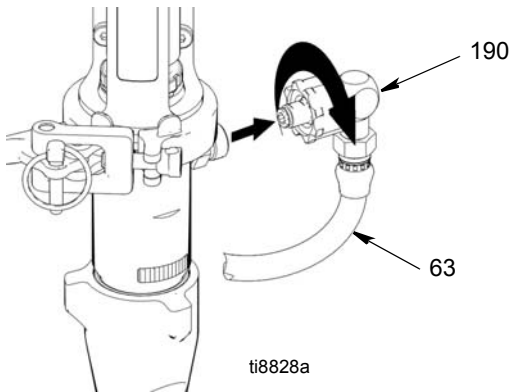

FIG. 14

- 5 (Fig. 15) Slide coupler cover (193) up to fully expose rod couplers (179).

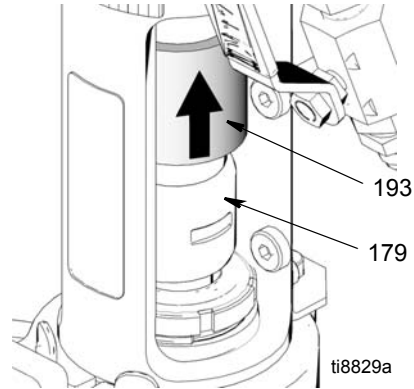

FIG. 15

- 6 (Fig. 16) Remove rod couplers (179).

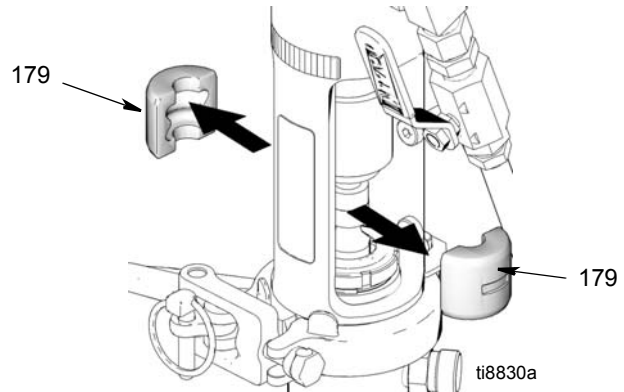

FIG. 16

- 7 (Fig 17) Remove pin.

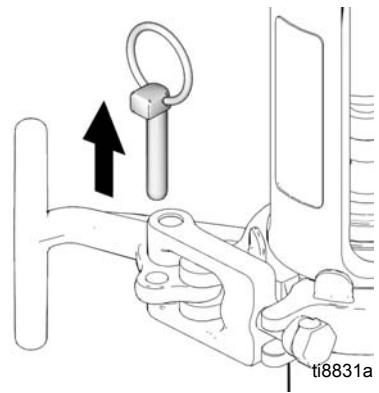
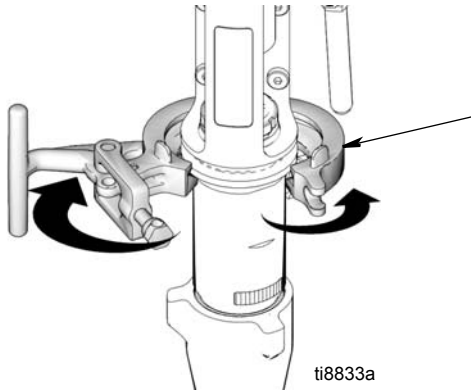

FIG. 17

**CAUTION**

Support pump with your hand before opening t-handle.

- 8 (Fig. 18) Open clamp (247).



**FIG. 18**

- 9 (Fig. 19) Remove pump (111) from unit.

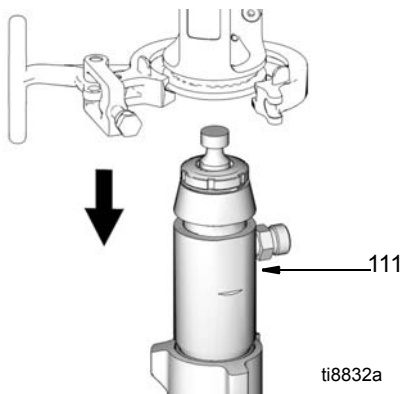

**FIG. 19**

**Installation**

- 1 (Fig. 20) If needed, place pump rod in adjustment casting and pull pump to lengthen rod.

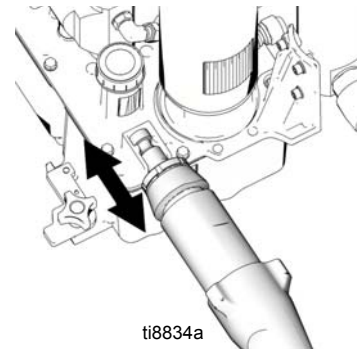

**FIG. 20**

- 2 (Fig. 21) Install pump (111) in sprayer.

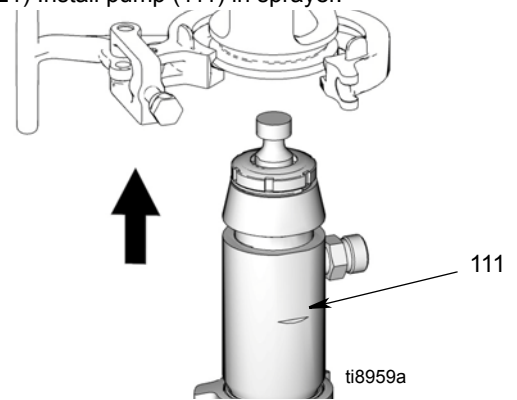

**FIG. 21**

- 3 (Fig. 22) Close clamp (247) around pump (111) and push it closed.

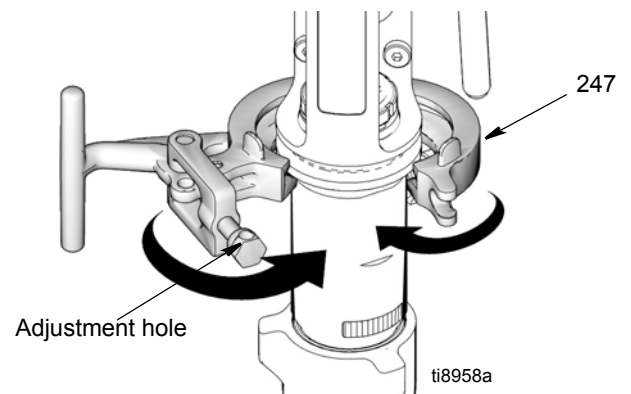

**FIG. 22**

NOTE: Closing force on T-handle can be adjusted if needed by inserting pin into adjustment hole and turning.

- 4 (Fig. 23) Install pin.

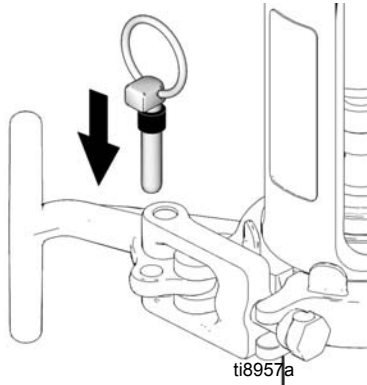

**FIG. 23**

- 5 (Fig. 24) Slide coupler cover (193) up to expose pump rod. Install rod couplers (179) over rod.

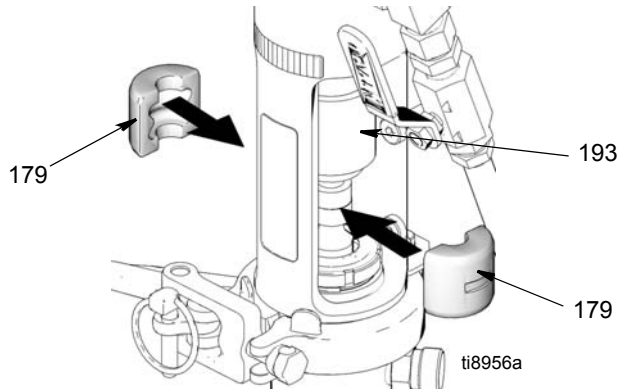

**FIG. 24**

- 6 (Fig. 25) Slide couple cover (193) down over rod couplers (179).

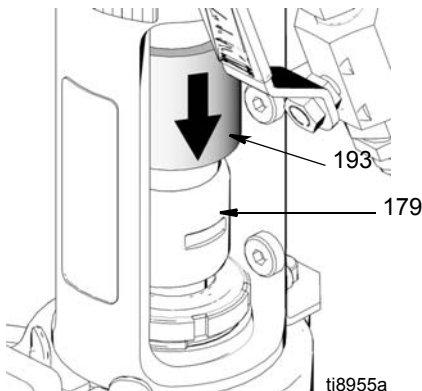

**FIG. 25**

- 7 (Fig. 26) Open clamp and align pump outlet with hose fitting (190). Install paint hose fitting (190) and paint hose (63) to pump connection, close clamp.

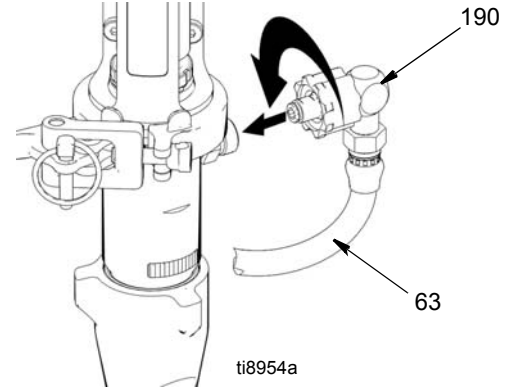

**FIG. 26**

- 8 (Fig. 27) Install suction hose (114) to bottom of pump (111).

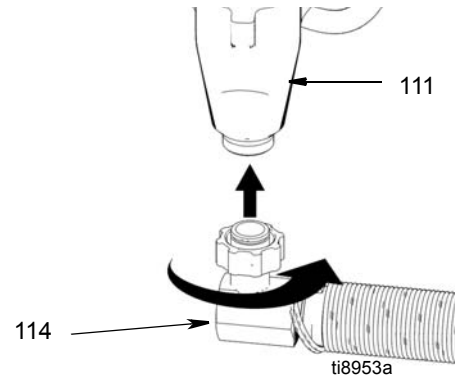
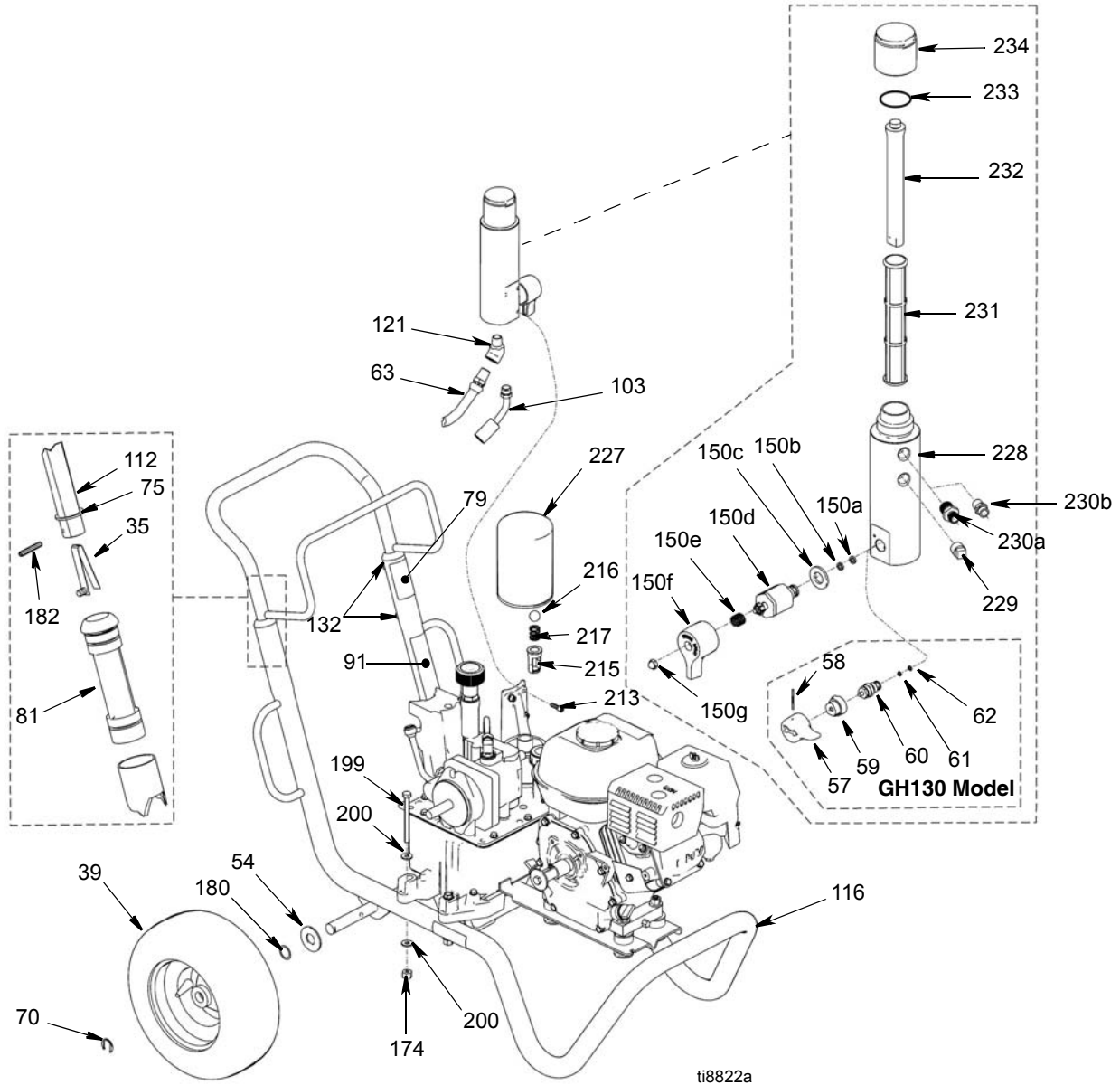

**FIG. 27**



# Parts

## All Sprayers



## Parts List - All Sprayers

Ref.	Part	Description	Qty	Ref.	Part	Description	Qty
35	112827	BUTTON, snap	2	230b‡	162485	ADAPTER (GH 230, 300) 3/8 npsm (m) hose connection	1
39	119420	WHEEL, pneumatic, GH130 & 200	2	231‡	244067	FILTER, fluid	1
	119408	WHEEL, pneumatic, GH230 & 300	2	232‡	15C766	TUBE, diffusion	1
54	156306	WASHER, flat, GH130 & 200	2	233‡	117285	PACKING, o-ring	1
	111841	WASHER, plain, 5/8, GH230 & 300	2	234‡	15C765	CAP, filter	1
57	15C780	HANDLE, GH130	1				
58	15C972	PIN, grooved, GH130	1				
59	224807	BASE, valve, GH130	1				
60	235014	VALVE, replacement, kit, GH130	1				
61◆	15E022	SEAT, valve, GH130	1				
62◆	277364	GASKET, seat, valve, GH130	1				
63	243814	HOSE	1				
70	120211	CLIP, retaining, GH130 & 200	2				
	15B563	CLIP, retaining, GH230 & 300	2				
75	15J645	WASHER, GH130 & 200	2				
	183350	WASHER, GH230, & 300	2				
79▲	189246	LABEL	1				
81	192027	SLEEVE, cart	2				
91▲	194317	LABEL	1				
103	288732	HOSE, drain	1				
112	24M397	HANDLE, cart	1				
116	288169	FRAME, cart, GH130 & 200	1				
	248815	CART, frame, GH230 & 300	1				
121	116756	ELBOW	1				
132	109032	SCREW, mach, pnh	4				
150‡	245103	VALVE, drain, GH200, 230, 300					
150a★	193710	SEAL, valve	1				
150b★	193709	SEAT, valve	1				
150c★	114797	GASKET	1				
150d★		VALVE, assembly	1				
150e★	114708	SPRING, compression	1				
150f★	15G563	HANDLE, valve	1				
150g★	116424	NUT, cap, hex hd	1				
174	110838	NUT, hex	2				
180	116038	WASHER, wave spring, GH130 & 200	2				
182	101354	PIN, spring, straight, GH130 & 200	2				
	108068	PIN, spring, straight, GH230 & 300	2				
199	803298	SCREW, hex head, GH130 & 200	2				
	867539	SCREW, hex head, GH230 & 300	2				
200	100527	WASHER	4				
213	119426	SCREW	3				
215	198841	RETAINER	1				
216	100084	BALL, metallic	1				
217	116967	SPRING, compression	1				
227	246173	FILTER, oil, spin on	1				
228‡	15E599	HOUSING	1				
229‡	100040	PLUG, pipe	1				
230a	164672	ADAPTER (GH 130, 200) 1/4 npsm (m) hose connection	1				

▲ *Danger and Warning labels, are available at no cost.*

◆ *Included in Drain Valve Replacement Kit 235014*

★ *Included in Drain Valve Replacement Kit 245103*

‡ *Included in Filter Replacement Kit 24W753*

# Parts Drawing - Engines

## GH130, 200, 230

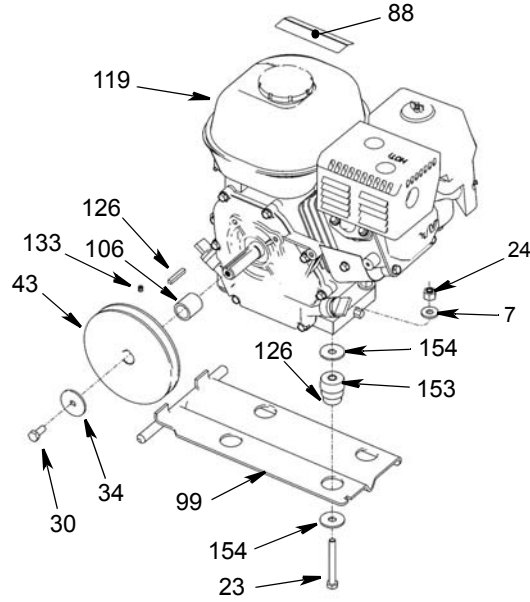

## GH300

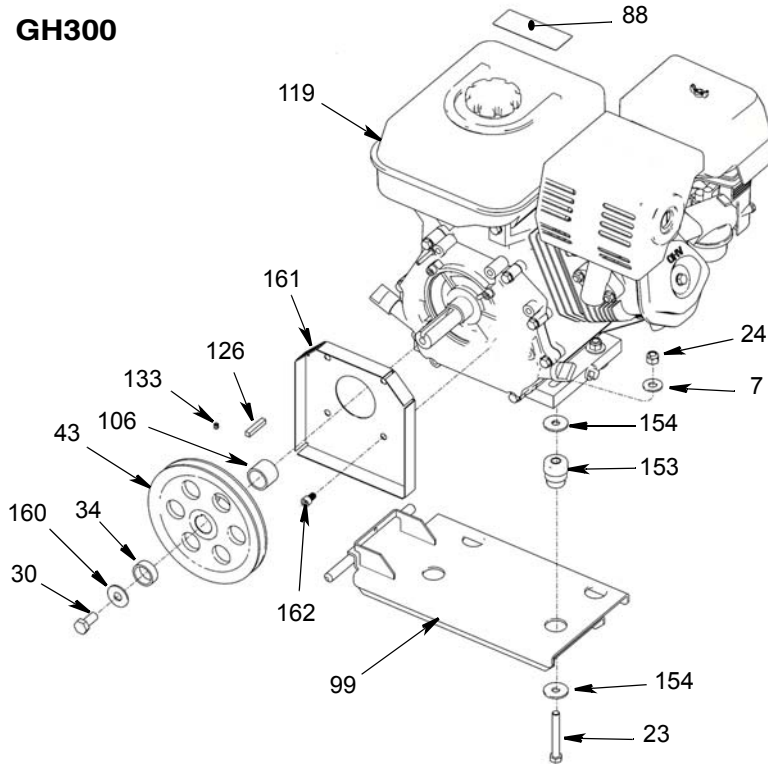

ti8813a



## Parts List - Engines

Ref.	Part	Description	Qty	
7	100023	WASHER, flat, GH130, 200 & 230	4	
	100132	WASHER, flat, GH300	4	
23	113664	SCREW, cap, hex hd, GH130, 200 & 230	4	
	106212	SCHREW, cap, hex hd, GH300	4	
24	110838	NUT, lock, GH130, 200 & 230	4	
	101566	NUT, lock, GH300	4	
30	108842	SCREW, cap, hex hd, GH130, 200 & 230	1	
	116645	SCREW, cap, hex hd, GH300	1	
34	112717	WASHER, GH130, 200 & 230	1	
	119438	WASHER, GH300	1	
43	116908	PULLEY, 5.50 in, GH130, 200 & 230	1	
	119401	PULLEY, GH300	1	
88▲	194126	LABEL	1	
99	15F157	BRACKET, mounting, engine, GH130, 200 & 230	1	
	15E583	BRACKET, mounting, engine, GH300	1	
106	15B314	SLEEVE, motor shaft, GH130, 200 & 230	1	
	15E586	SLEEVE, motor shaft, GH300	1	
119*	120590	ENGINE, gasoline, 120 cc, Honda, GH130	1	
	802264	ENGINE, gasoline, 160 cc, GH200	1	
	116298	ENGINE, gasoline, 200 cc, Honda, GH230	1	
	803900	ENGINE, gasoline, 270 cc, Honda, GH300	1	
126	117632	KEY, square, 3/16 X 1.25, GH130, 200 & 230	1	
	119484	KEY, parallel, square, GH300	1	
133	100002	SCREW, set, sch	1	
153	15E888	DAMPENER, motor mount, GH130, 200 & 230	4	
	195515	DAMPENER, motor mount, GH300	4	
154	108851	WASHER, plain	8	
160	15E764	SPACER, GH300	1	
161	15E973	SHIELD, GH300	1	
162	C20010	SCREW, GH300	5	

\*Engine Repair Kits:

288678	120 cc (4.0 HP)
248943	160 cc (5.5 HP)
248944	200 cc (6.5 HP)
248945	270 cc (9.0 HP)

▲Danger and Warning labels, are available at no cost.

# Parts Drawing - All Sprayers

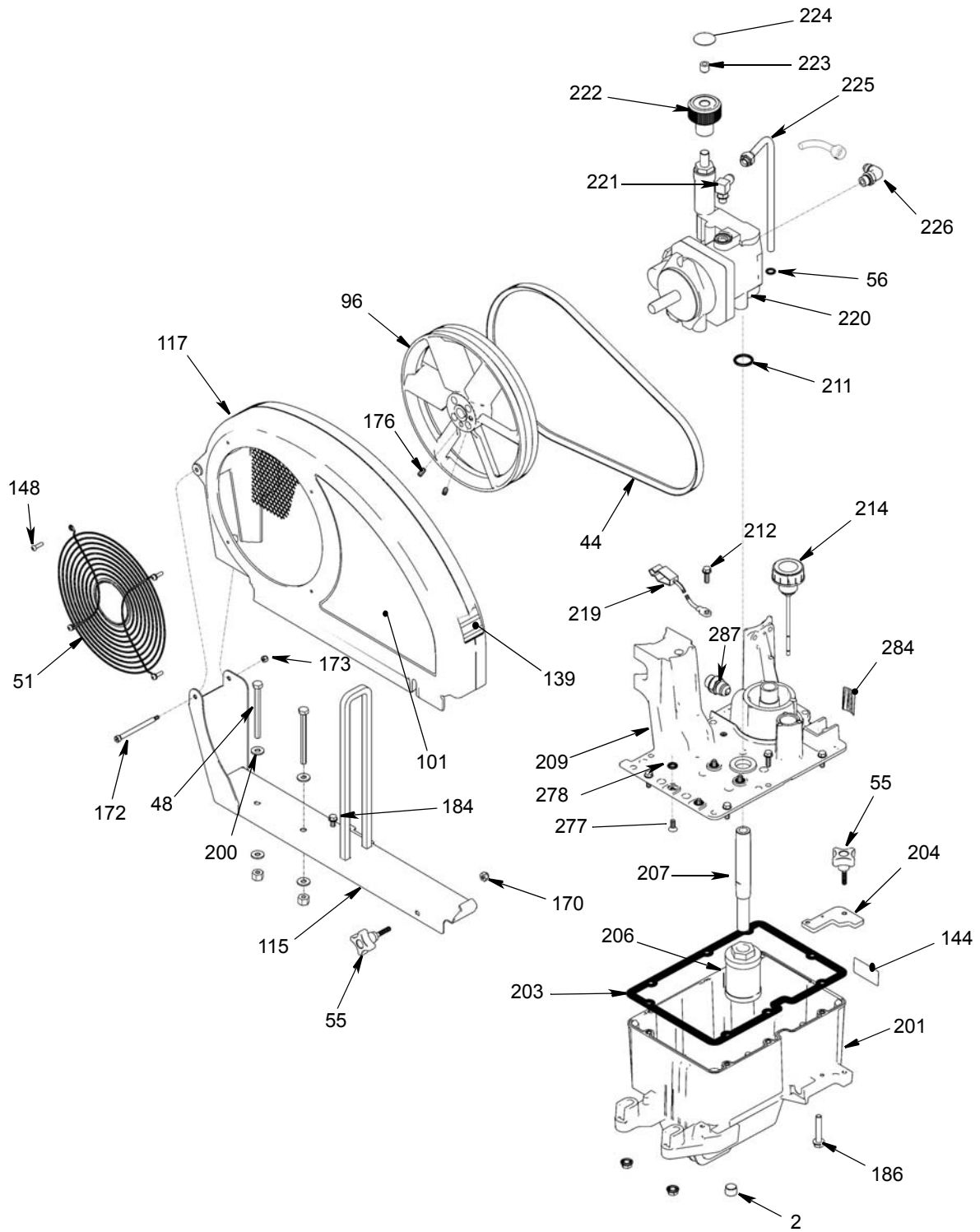

ti8823b

## Parts List - All Sprayers

Ref.	Part	Description	Qty				
				220	288733	PUMP, hydraulic, GH130	1
					246178	PUMP, hydraulic, GH200	
					249003	PUMP, hydraulic, 230/300	
2	101754	PLUG	1				
44	119433	BELT, GH130, 200, 230	1	221	110792	FITTING, elbow, male, 90°	1
	119432	BELT, GH300	1	222	15B438	KNOB, pressure	1
48	803298	SCREW, hex head GH130 & 200	2	223	117560	SCREW, set, socket head	1
	867539	SCREW, hex head GH230 & 300	2	224▲	15A464	LABEL, control	1
51	117284	GRILL, fan guard	1	225	246167	TUBE, hydraulic, case drain	1
55	15D862	NUT, hand	2	226	116829	FITTING, elbow, with o-rings	1
56	154594	O-RING	1	277	117471	SCREW	4
96	15E410	PULLEY, fan	1	278	107188	PACKING, o-rings	4
99	15F157	BRACKET, mounting, engine, GH130, 200 & 230	1	284▲	198585	LABEL	1
	15E583	BRACKET, mounting, engine, GH300	1	287	120184	FITTING	1
101▲	15K431	LABEL, GH130	1	▲ Danger and Warning labels, are available at no cost.			
	15K433	LABEL, GH200	1				
	15K435	LABEL, GH230	1				
	15K437	LABEL, GH300	1				
115	288261	RAIL, belt guard, assembly, GH130 & 200	1				
	288393	RAIL, belt guard, assembly, GH230 & 300	1				
117	288734	GUARD, belt assembly, painted, GH130 & 200	1				
	248973	GUARD, belt, assembly, painted, GH230 & 300	1				
139▲	198492	LABEL	1				
144▲	15K440	LABEL	1				
148	115477	SCREW, mach, torx pan hd	4				
170	102040	NUT, lock, hex	1				
172	119434	SCREW, shoulder, socket head	1				
173	116969	NUT, lock	1				
176	120087	SCREW, set, 1/4 X 1/2	2				
184	260212	SCREW, hex washer hd, thd form	1				
186	120655	SCREW, mach, hex washer head, GH130 & 200	2				
	17D142	SCREW, mach, hex washer head, GH230 & 300	2				
200	100527	WASHER	2				
201	15J513	TANK, reservoir	1				
202	101754	PLUG, pipe	1				
203	120604	GASKET, reservoir	1				
204	15E476	BRACKET, retainer, motor	1				
206	116919	FILTER	1				
207	15E587	TUBE, suction	1				
208	154594	PACKING, o-ring	1				
209	15J363	COVER, reservoir	1				
211	156401	PACKING, o-ring	1				
212	119426	SCREW	8				
214	120726	CAP, breather, filler	1				
219	237686	WIRE, ground with clamp	1				

# Parts Drawing - Sprayers, OEM Kits

## GH200/230/300

## GH130

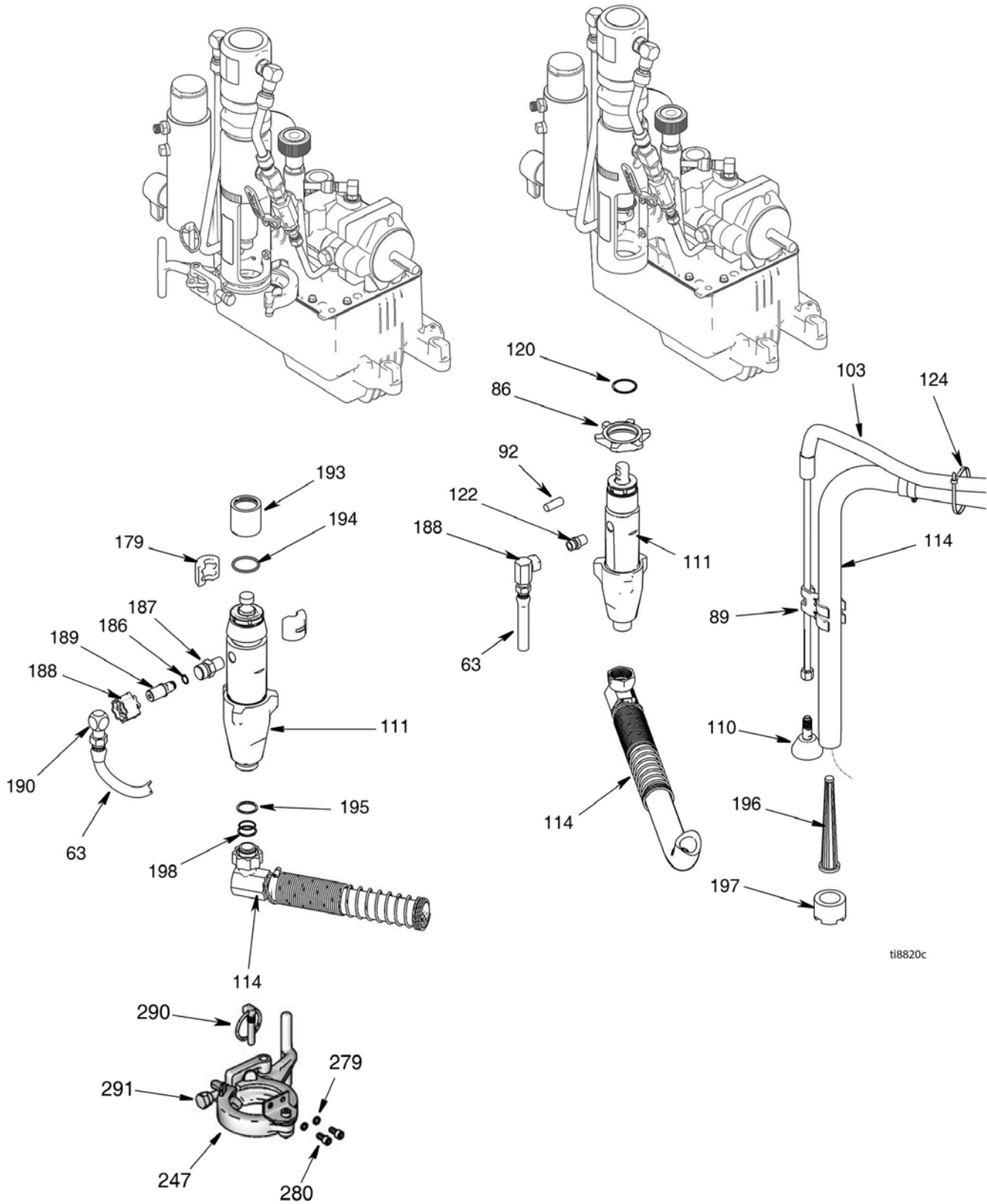

ti8820c

## Parts List - Sprayers, OEM Kits

Ref.	Part	Description	Qty
			.
63	243814	HOSE, coupled	1
86	193031	NUT, retaining, GH130	1
89	15D000	CLIP, drain line	1
92	15J141	PIN, pump, GH130	1
103	288732	KIT, drain hose	1
110	241920	DEFLECTOR, threaded	1
111	24B748	PUMP, kit, displacement, GH130	1
	288467	PUMP, kit, displacement, GH200	1
	288468	PUMP, kit, displacement, GH230 & 300	1
114	288251	HOSE, suction, 5 gallon, GH130	1
	288252	HOSE, suction, 5 gallon, GH200, 230 & 300	1
115	208259	Hose, suction, 30/55 gallon, GH130 (not shown)	1
	289669	HOSE, suction, 30/55 gallon, GH200/230/300 (not shown)	1
120	116551	RING, retaining, GH130	1
122	162485	ADAPTER, nipple, GH130	1
	196178	ADAPTER, nipple, GH130 OEM	1
124	114958	STRAP, tie	4
179	277377	COUPLER	2
186	107505	PACKING, o-ring	1
187	15J413	FITTING, pump, QD	1
188	120583	NUT, hand, GH200/230/300	1
	207123	UNION, swivel, 90° GH130 OEM	1
189	15J410	FITTING, QD	1
190	155699	FITTING, elbow, street, sprayer	1
	196179	FITTING, elbow, street, GH200/230/300 OEM	1
193	15H957	COVER, coupler	1
194	156698	PACKING, o-ring	1
195	119566	WASHER, garden hose	1
196*	288472	INLET FILTER, 10 mesh, standard	1
	289131	INLET FILTER, 16 mesh	1
197*	288480	NUT, strainer, inlet	1
198	117559	O-RING	2
247	288344	CLAMP, pump; GH 200, 230, 300	1
279	105510	WASHER, lock, spring (hi-collar), GH200, GH230, GH300	2
280	101550	SCREW, cap, sch	2
290	288741	KIT, repair, pin/spacer; GH 200, 230, 300	1
291	15J417	BOLT, adjustment; GH 200, 230, 300	1

\* Included in Accessory Kit 288481 (10 mesh) or Accessory Kit 289132 (16 mesh)

# Parts Drawing

## Sprayers

## OEM Kits

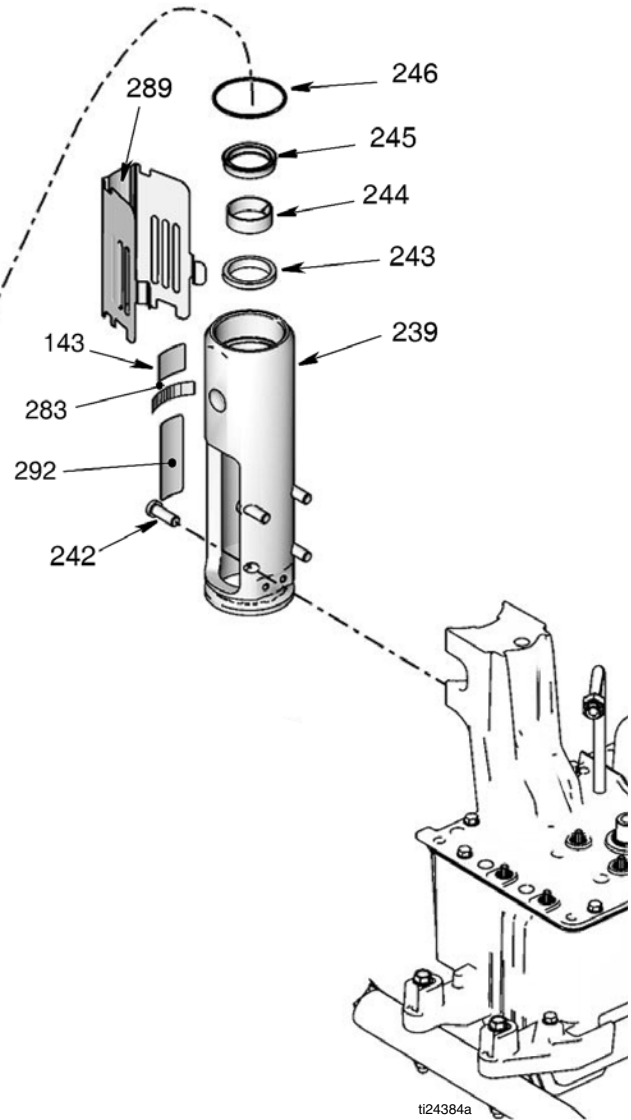
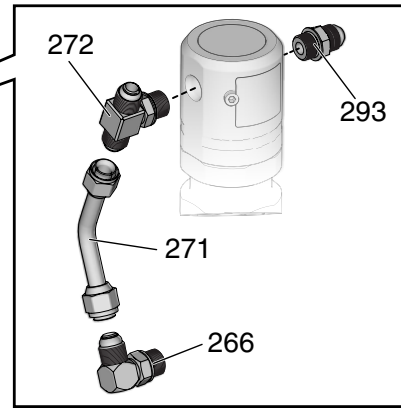
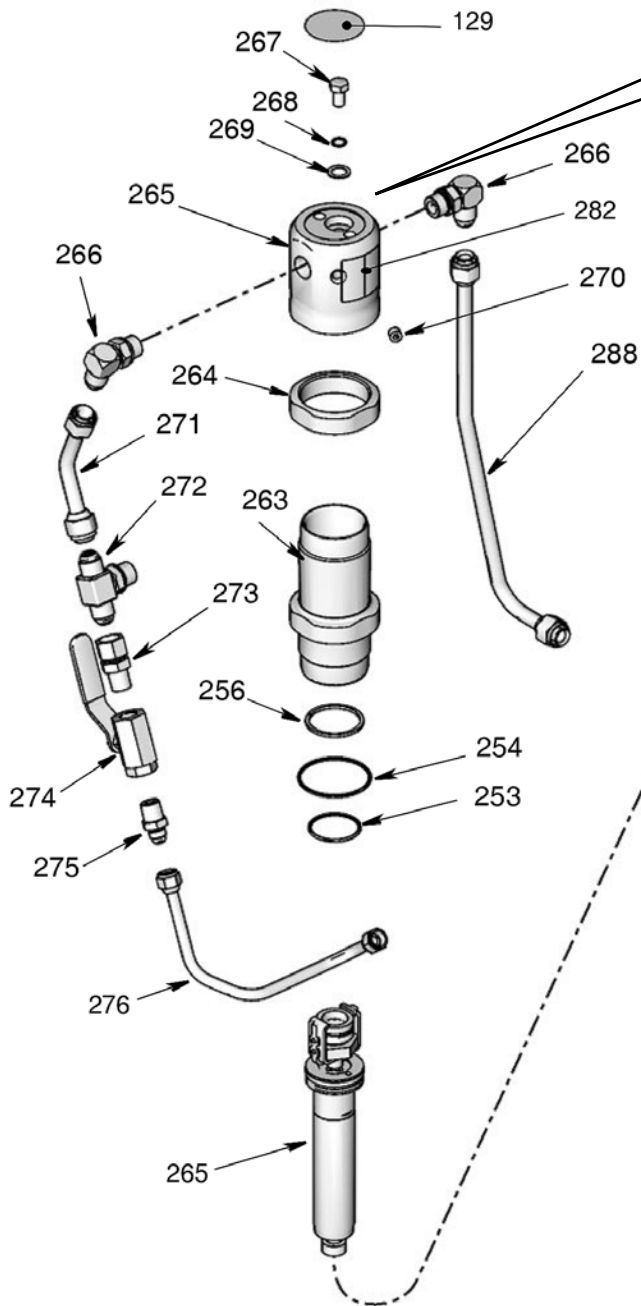

t24384a

## Parts List - Sprayers, OEM Kits

Ref.	Part	Description	Qty
			15J845 TUBE, hydraulic, return, GH200 1
			15J863 TUBE, hydraulic, return, GH230 & 300 1
129▲◆✓	15B063	LABEL	1
143▲◆	15K430	LABEL, GH130	1
	15K432	LABEL, GH200	1
	15K434	LABEL, GH230	1
	15K436	LABEL, GH300	1
239◆	15H953	MANIFOLD, GH130	1
	15J278	MANIFOLD, GH200	1
	15J279	MANIFOLD, GH230 & 300	1
242◆	15B564	SCREW, cap socket	4
243‡◆	117739	WIPER, rod	1
244‡◆	112342	BEARING, rod	1
245‡◆	112561	PACKING, block	1
246‡◆	117283	PACKING, o-ring	2
253‡◆✓	108014	PACKING, o-ring	1
254‡◆✓	178226	SEAL, piston	1
256‡◆✓	178207	BEARING, piston	1
263◆	246176	SLEEVE, hydraulic cylinder, kit, GH130 & 200	1
	248991	SLEEVE, hydraulic cylinder, kit, GH230 & 300)	1
264◆	15A726	NUT, jam	1
265◆	288735	KIT, repair, trip rod, piston; GH130 only	1
	288736	KIT, repair, trip rod, piston; GH 200 only	1
	288737	KIT, repair, trip rod, piston; GH 230/300 only	1
266◆	117607	FITTING, elbow std thd	2
267✓◆	106276	SCREW, cap, hex head	1
268✓◆	155685	PACKING, o-ring	1
269✓◆	178179	WASHER, sealing	1
270✓◆	100139	PLUG, pipe	1
271◆	198629	TUBE, hydraulic, supply, GH130 & 200	1
	15E596	TUBE, hydraulic, supply, GH230 & 300	1
272◆	117609	FITTING, tee, branch, str thd	1
273	117328	FITTING, nipple, straight	1
274	117441	VALVE, ball	1
275	116813	FITTING, nipple, hydraulic	1
276	15J819	TUBE, hydraulic, supply, GH130	1
	15J846	TUBE, hydraulic, supply, GH200	1
	15J864	TUBE, hydraulic, supply, GH230, GH300	1
282▲◆✓	15B804	LABEL	1
283▲◆	192840	LABEL	1
288	15J824	TUBE, hydraulic, return, GH130	1

▲Danger and Warning labels, are available at no cost.

◆Included in Hydraulic Motor Repair Kit: 288758 - GH130; 288759 - GH200; 288760 - GH230 & 300

✓Included in Trip Rod/Piston Kit: 288735 - GH130; 288736 - GH200; 288737 - GH230 & 300

‡Included in Seal Kit 246174

## GH130 & 200 Sprayers with Spray Gun and Hoses

Ref.	Part No.	Description	Qty.
202	288489	KIT, gun, Contractor 3300 psi (227 bar, 22.7 MPa) Includes 202a - 202d	1
202a	240794	HOSE, grounded, nylon; 1/4 in. ID; cpld 1/4-18 npsm; 50 foot (15 m); spring guards both ends 3300 psi (227 bar, 22.7 MPa)	1
202b	238358	HOSE, grounded, nylon; 3/16 in. ID; cpld 1/4 npt(m) x 1/4 npsm(f); 3 foot (0.9 m); spring guards both ends 3300 psi (227 bar, 22.7 MPa)	1
202c	288420	Contractor Spray Gun Includes 517 RAC <sup>®</sup> X SwitchTip and HandTite <sup>™</sup> Guard See 311861 for parts	1

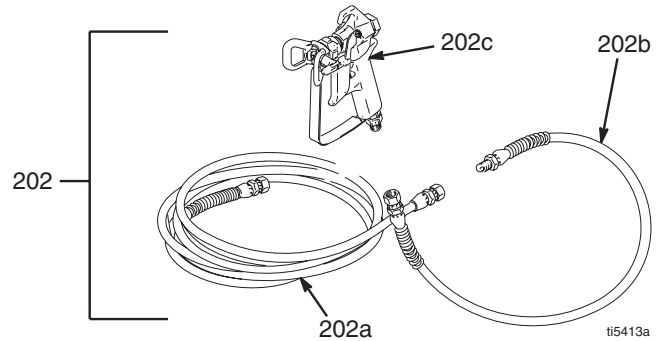

## GH230 & 300 Sprayers with Spray Gun and Hoses

Ref.	Part No.	Description	Qty.
202	287042	KIT, gun, Silver 3300 psi (227 bar, 22.7 MPa) Includes 202a - 202d	1
202a	240797	HOSE, grounded, nylon; 3/8 in. ID; cpld 3/8-18 npsm; 50 foot (15 m); spring guards both ends 3300 psi (227 bar, 22.7 MPa)	1
202b	241735	HOSE, grounded, nylon; 1/4 in. ID; cpld 1/4 npt(m) x 1/4 npsm(f); 3 foot (0.9 m); spring guards both ends 3300 psi (227 bar, 22.7 MPa)	1
202c	246240	Silver Spray Gun Includes 517 RAC <sup>®</sup> X SwitchTip and HandTite <sup>™</sup> Guard See 311254 for parts	1
202d	159841	ADAPTER, 3/8 X 1/4 in. npt	1

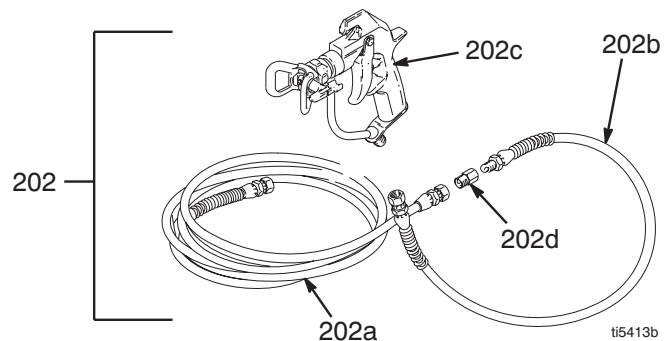



## Sprayers Technical Data

Sprayer	Fluid Pressure psi (bar)	Hydraulic Reservoir Capacity Gallons (Liters)	Maximum Hydraulic Pressure psi (bar)	Engine cc (HP)	Maximum Delivery gpm (lpm)	Maximum Tip Size	Fluid Inlet in.	Hose Connection  npsm (m)	Fluid Outlet  npt(f)
GH130	3300 (227)	1.25 (4.75)	1510 (104)	120 (4.0)	1.30 (5.9)	0.037	3/4 npt (m)	1/4	3/8
GH200	3300 (227)	1.25 (4.75)	1855 (128)	160 (5.5)	2.15 (9.8)	0.047	1 5/16-12 UN-ZA	1/4	3/8
GH230	3300 (227)	1.25 (4.75)	1855 (128)	200 (6.5)	2.35 (10.7)	0.053	1 5/16-12 UN-ZA	3/8	3/8
GH300	3300 (227)	1.25 (4.75)	1855 (128)	270 (9.0)	3.0 (11.4)	0.057	1 5/16-12 UN-ZA	3/8	3/8

### Basic Sprayer Wetted Parts:

Zinc and nickel-plated carbon steel, stainless steel, PTFE, acetal, chrome plating, leather, V-Maxt UHMWPE, stainless steel, tungsten carbide, ceramic, nylon, aluminum

## Sound Levels\*

Engine	Sound Pressure dB(A)	Sound Power dB(A)
120 cc (4.0 HP)	88	103
160 cc (5.5 HP)	96	110
200 cc (6.5 HP)	96	110
270 cc (9.0 HP)	96	110

\*Measured at maximum normal load conditions (gas only).

## Dimensions

Sprayer	Weight lb (kg)	Width in. (cm)	Length in. (cm)
GH130	155 (70.3)	24 (61)	41 (104.1)
GH200	160 (73.4)	24 (61)	41 (104.1)
GH230	168 (75.6)	24 (61)	48 (121.92)
GH300	195 (87.8)	24 (61)	48 (121.92)

# OEM Kits Technical Data

OEM Kit	Paint/ Hydraulic Pressure Ratio	User Supplied Input			Unit Output		Dimensions			Weight (lb/kg)
		Max Hydraulic Pressure (psi/MPa/ bar)	Hydraulic Flow Required in Free Flow (gpm/lpm)	Max Cycle Rate (cpm)	Max Fluid Pressure (psi/MPa/ bar)	Max Flow (gpm/lpm)	Height (in/mm)	Width (in/mm)	Depth (in/mm)	
GH130	2.19:1	1510/10.4/1 04.1	4.01/15.2	125	3300/22.8/ 227.5	1.30/4.92	25.4/645	5.70/145	3.14/80	27.5/12.5
GH200	1.78:1	1855/12.8/1 27.9	5.13/19.4	160	3300/22.8/ 227.5	2.15/8.14	25.60/650	5.39/137	5.39/137	32.5/14.7
GH230/300	1.78:1	1855/12.8/1 27.9	6.60/25.0	145	3300/22.8/ 227.5	3.0/11.4	28.80/732	8.94/227	5.38/137	35/15.9

## GH130 OEM

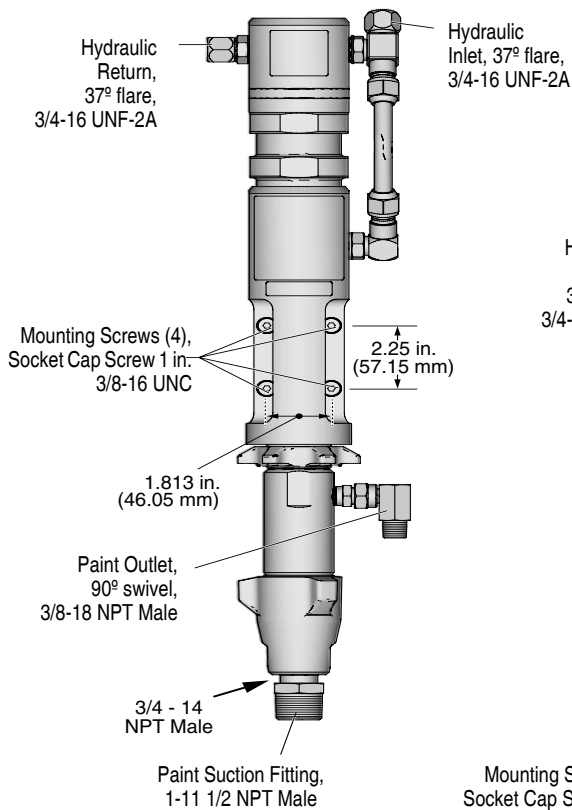

## GH200 OEM

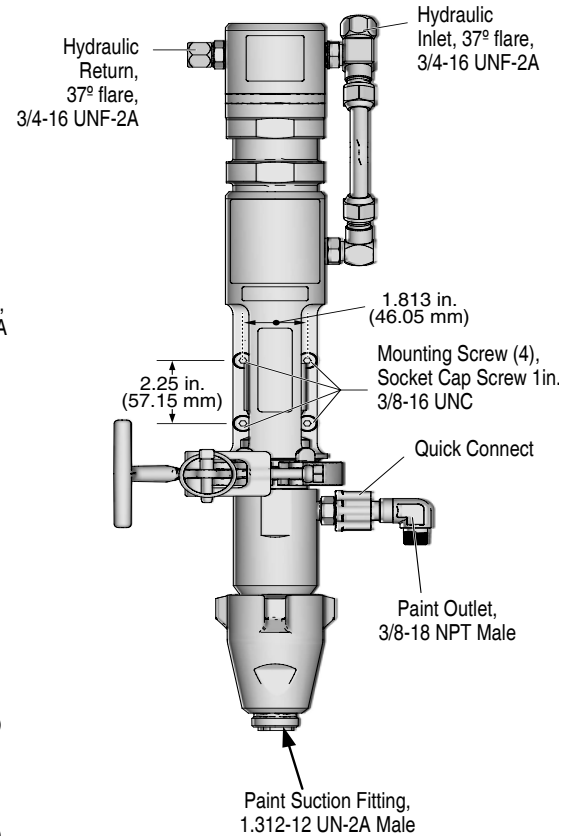

## GH230/300 OEM

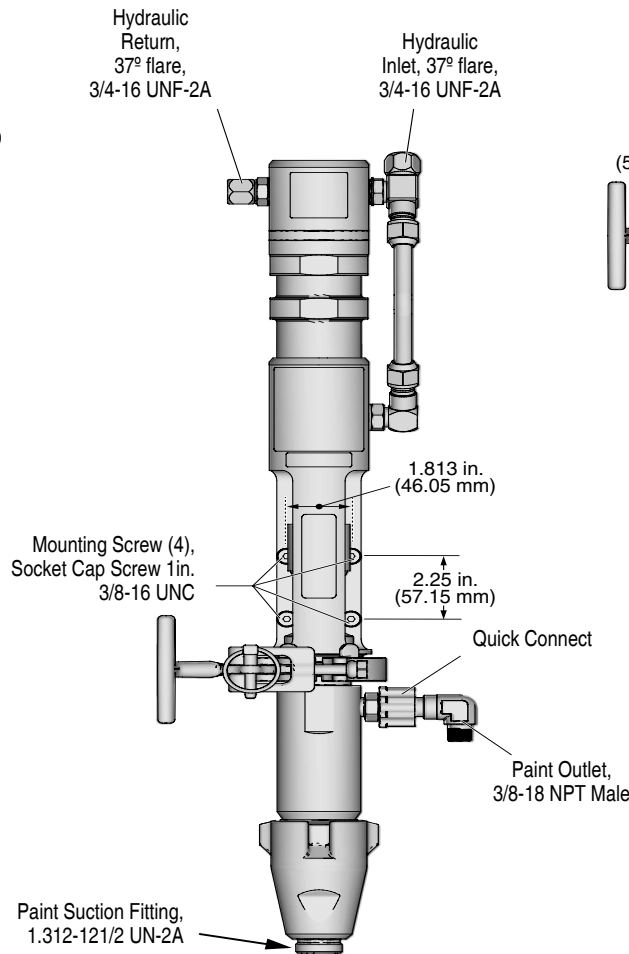

ti24313b



# Graco Standard Warranty

Graco warrants all equipment referenced in this document which is manufactured by Graco and bearing its name to be free from defects in material and workmanship on the date of sale to the original purchaser for use. With the exception of any special, extended, or limited warranty published by Graco, Graco will, for a period of twelve months from the date of sale, repair or replace any part of the equipment determined by Graco to be defective. This warranty applies only when the equipment is installed, operated and maintained in accordance with Graco's written recommendations.

This warranty does not cover, and Graco shall not be liable for general wear and tear, or any malfunction, damage or wear caused by faulty installation, misapplication, abrasion, corrosion, inadequate or improper maintenance, negligence, accident, tampering, or substitution of non-Graco component parts. Nor shall Graco be liable for malfunction, damage or wear caused by the incompatibility of Graco equipment with structures, accessories, equipment or materials not supplied by Graco, or the improper design, manufacture, installation, operation or maintenance of structures, accessories, equipment or materials not supplied by Graco.

This warranty is conditioned upon the prepaid return of the equipment claimed to be defective to an authorized Graco distributor for verification of the claimed defect. If the claimed defect is verified, Graco will repair or replace free of charge any defective parts. The equipment will be returned to the original purchaser transportation prepaid. If inspection of the equipment does not disclose any defect in material or workmanship, repairs will be made at a reasonable charge, which charges may include the costs of parts, labor, and transportation.

Graco's sole obligation and buyer's sole remedy for any breach of warranty shall be as set forth above. The buyer agrees that no other remedy (including, but not limited to, incidental or consequential damages for lost profits, lost sales, injury to person or property, or any other incidental or consequential loss) shall be available. Any action for breach of warranty must be brought within two (2) years of the date of sale.

**GRACO MAKES NO WARRANTY, AND DISCLAIMS ALL IMPLIED WARRANTIES OF MERCHANTABILITY AND FITNESS FOR A PARTICULAR PURPOSE, IN CONNECTION WITH ACCESSORIES, EQUIPMENT, MATERIALS OR COMPONENTS SOLD BUT NOT MANUFACTURED BY GRACO.** These items sold, but not manufactured by Graco (such as electric motors, switches, hose, etc.), are subject to the warranty, if any, of their manufacturer. Graco will provide purchaser with reasonable assistance in making any claim for breach of these warranties.

In no event will Graco be liable for indirect, incidental, special or consequential damages resulting from Graco supplying equipment hereunder, or the furnishing, performance, or use of any products or other goods sold hereto, whether due to a breach of contract, breach of warranty, the negligence of Graco, or otherwise.

## **FOR GRACO CANADA CUSTOMERS**

The Parties acknowledge that they have required that the present document, as well as all documents, notices and legal proceedings entered into, given or instituted pursuant hereto or relating directly or indirectly hereto, be drawn up in English. Les parties reconnaissent avoir convenu que la rédaction du présente document sera en Anglais, ainsi que tous documents, avis et procédures judiciaires exécutés, donnés ou intentés, à la suite de ou en rapport, directement ou indirectement, avec les procédures concernées.

## **ADDITIONAL WARRANTY COVERAGE**

Graco does provide extended warranty and wear warranty for products described in the Graco Contractor Equipment Warranty Program.

# Graco Information

For the latest information about Graco products, visit [www.graco.com](http://www.graco.com).

For patent information, see [www.graco.com/patents](http://www.graco.com/patents).

**TO PLACE AN ORDER**, contact your Graco distributor or call 1-800-690-2894 to identify the nearest distributor.

*All written and visual data contained in this document reflects the latest product information available at the time of publication. Graco reserves the right to make changes at any time without notice.*

Original instructions. This manual contains English. MM 311797

**Graco Headquarters:** Minneapolis

**International Offices:** Belgium, China, Japan, Korea

**GRACO INC. AND SUBSIDIARIES • P.O. BOX 1441 • MINNEAPOLIS MN 55440-1441 • USA**

**Copyright 2007, Graco Inc. All Graco manufacturing locations are registered to ISO 9001.**

[www.graco.com](http://www.graco.com)

Revised November 2014