

## MST Portable Air Filtration System

*“Save  
Your  
Breath  
With* **NST**®  
MODERN SAFETY TECHNIQUES

11388 Breininger Rd. Phone: (800) 542-6646  
P.O. Box 87 (888) mod-safe  
Hicksville, OH 43526 (419) 542-6645  
Website: www.modsafe.com Fax: (419) 542-6475  
Email: modsafe@bright.net

SERVICE MANUAL  
MODEL BA100BMST  
100 SCFM PORTABLE AIR PANEL

\*\*\*\*\*  
WARNING: Do not attempt to operate this equipment without first reading and understanding the  
service manual enclosed with this device.  
\*\*\*\*\*

3/27/02

## 2

**GENERAL OPERATION MANUAL****WARNING: The Portable Air Panel Model BA100BMST:**

- 1) WILL NOT remove Carbon Monoxide.
- 2) SHALL NOT be used when the air entering the filtering system is oxygen deficient. The Air Panel will not increase the oxygen content of the air.
- 3) SHALL NOT be used in an Immediately Dangerous to Life and Health Atmosphere (IDLH) unless it is used in conjunction with a Back-Up Escape system or a supplied air Self-Contained Breathing Apparatus (SCBA), where applicable.

**WARNING: The Carbon Monoxide Monitor used in this device will alarm if the incoming air's carbon monoxide content exceeds a pre-determined alarm set point (depending on the applicable standard). If the monitor's alarm should sound, remove respirator, or activate escape air supply or SCBA if applicable, and move immediately to a safe breathable atmosphere. Have the proper qualified personnel examine the equipment and make the appropriate corrections before using again.**

- 4) SHALL NOT have air inlet pressure greater than 150 PSIG static (10.4 bar). Personal injury could result.
- 5) SHALL NOT have air outlet pressure that exceeds Manufacturers' Respirator/Hose Assembly pressure requirements. Personal injury could result.

The Portable Air Panel is a Four Stage Filtration System designed to remove or reduce select contaminants found in compressed air lines while monitoring for carbon monoxide through an electrochemical Carbon Monoxide Monitor. The Portable Air Panel can be connected directly to shop air from a standard compressed air source to help provide breathing quality air to face masks, helmets, hoods and other supplied air-type breathing devices.

**GENERAL FILTER SYSTEM DESCRIPTION**

(Refer to Figure No.1)

Air entering the Portable Air Panel at the inlet (A) is usually contaminated with oil, water, dirt, rust, scale and gaseous Hydrocarbons. As the air passes through the First Stage (B) of the Prefilter, particulate matter is trapped and retained down to 0.3 microns. The air then enters the Second Stage (C) of the Prefilter which traps all particulate matter larger then 0.3 micron and coalesces liquid aerosols with an efficiency rating of 99.97% (D.O.P. 0.3-0.6 micron). MST's prefilter meets underwriters laboratory specification UL 586 for high efficiency, particulate, air filter units (HEPA rating). The liquid contaminates are trapped in the lower chamber of the prefilter and expelled out through the Automatic Float Drain (D). The Third and Fourth Stages (E & F) contain a deep bed of odor absorbing activated charcoal which collects various gaseous Hydrocarbons (such as oil fumes, benzene, etc.). The air is then passed through the Air Pressure Regulator (G), which is used to adjust the air pressure going to the respirator(s). A sample of the filtered air is taken at (H) and passed through the Carbon Monoxide Monitor (I). The Carbon Monoxide Monitor continuously checks the carbon monoxide levels per OSHA requirements and digitally displays the amount present in PPM (parts per million). An audio and visual alarm will alert operators if levels of carbon monoxide exceed OSHA (or other applicable standards) requirements.

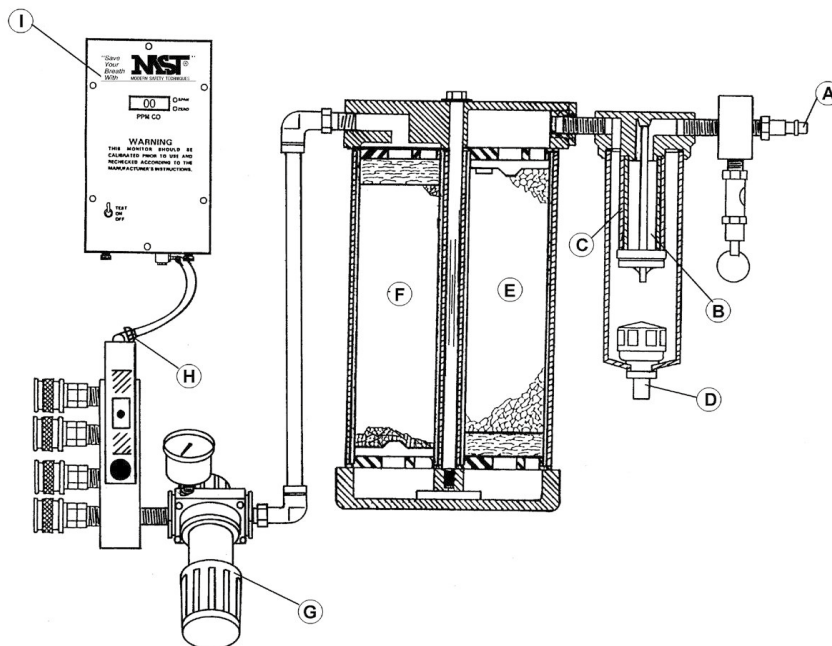

**FIGURE NO. 1**

**GENERAL INSTRUCTIONS**

The Model BA100BMST Portable Air Panel, a compressed air purifier, when used in accordance with the following instructions, will remove or reduce selected contaminants from compressed air lines.

\*\*\*\*\*  
**WARNING:** The Portable Air Panel Model BA100BMST should not be used when the air entering the filter is oxygen deficient (air with a low oxygen content). The Portable Air Panel will not increase the oxygen content of oxygen deficient air.  
\*\*\*\*\*

The Factory strongly recommends that a complete safety program be instated to ensure that the respiratory air is in compliance with all OSHA standards and other applicable laws regulating the use of supplied air respiratory systems, and the air quality be tested upon installation and periodically re-tested to ensure that the minimum requirements for breathing air are maintained.

\*\*\*\*\*  
**WARNING:** The Portable Air Panel Model BA100BMST will not remove Carbon Monoxide.  
\*\*\*\*\*

The Carbon Monoxide Monitor in the Portable Air Panel Model BA100BMST is a CSA Certified "Intrinsically Safe" monitor. Refer to the Monitor's Information Manual for charging, calibration, and operating instructions. The Factory will not assume any liability for accidents or personal injury resulting from the improper use of this equipment. Service on this equipment should only be performed by qualified personnel.

This system is to be used only by trained qualified personnel in accordance with a respirator program as outlined in OSHA Regulation 29 CFR 1910.134(b).

The air supply entering The Portable Air Panel must meet two (2) criteria to ensure maximum efficiency of the filter system:

- 1) Temperature range should be between 35-150°F (2-65°C)
- 2) Liquid size range should be between 2-8 microns.

Conditioning equipment may be necessary, prior to the filter, to achieve this temperature range and bulk liquid removal.

\*\*\*\*\*  
**WARNING:** Maximum pressure supplied to this unit IS NOT to exceed 150 PSIG. Personal injury could result.  
\*\*\*\*\*

The Regulator (80075) is used to adjust the air pressure supplied to the operator(s) to maintain the correct air exchange inside the mask, hood or helmet. Consult instructions on your particular breathing mask or hood for the proper pressure required. The Portable Air Panel Model BA100BMST is supplied with Industrial Interchange Quick-Disconnects. The quick-disconnects supplied on the mask and hose assembly from the manufacturer shall be used to validate the NIOSH approval on the mask and hose assembly.

\*\*\*\*\*  
**WARNING: DO NOT Exceed mask and hose assembly manufacturer's requirements for outlet pressures. Personal injury could result.**  
\*\*\*\*\*

The filter cartridges used in the Portable Air Panel Model BA100BMST have an average life expectancy of (1) one month, (depending on the quality of the air in your compressed air lines) under normal conditions. The Factory recommends changing all three (3) filter cartridges after one month of use unless conditions warrant more or less frequent replacement.

\*\*\*\*\*  
**WARNING: If the Monitor's alarm should sound, activate your emergency escape system, or self-contained breathing apparatus (SCBA) when applicable, (or if you are NOT in an immediately dangerous to life and health atmosphere [IDLH] remove your mask or helmet) and move immediately to a non-contaminated atmosphere. Have the proper qualified personnel examine the equipment and make the appropriate corrections before using again.**  
\*\*\*\*\*

The Carbon Monoxide Alarm will sound to alert the operator that a problem has developed. The Monitor Alarm will sound due to one or more of the following conditions:

- A) Carbon Monoxide levels exceeding a pre-determined alarm set level is passing through the Portable Air Panel. The Portable Air Panel **DOES NOT REMOVE** or reduce the Carbon Monoxide content in the compressed air. Examine the air compressor, the air compressor intake air quality, and the complete system. Have the proper qualified personnel make the appropriate corrections before using again.
- B) Monitor out of Calibration. Calibrate Carbon Monoxide Monitor as outlined in the Monitor's Information Manual.
- C) The Monitor's carbon monoxide sensor may be bad. See the Monitor's Information Manual for all maintenance on the monitor.

**SERVICE INSTRUCTIONS**

(Refer to Figure No. 2)

\*\*\*\*\*  
**WARNING: Always turn off air supply and bleed air pressure before disassembling unit or  
 SERIOUS INJURY COULD RESULT.**  
 \*\*\*\*\*

The Factory recommends replacing all three (3) filter cartridges after one (1) month of use unless conditions warrant more or less frequent replacement. To refill or replace the filter cartridges in the Portable Air Panel Model BA100BMST, follow these steps:

1. **PREFILTER FIRST/SECOND DUAL STAGE ELEMENT REPLACEMENT**

- A) First pull Drain Tube (1) up through case, then unscrew Prefilter bowl Assembly (2). Clean in mild soap and water and blow dry with low pressure air.
- B) Remove Dual Stage Element (3) by unscrewing End Cap Retaining Nut (4).
- C) Inspect the Prefilter Manifold (5) for dirt/contaminates and clean as required. Inspect "O"-Ring (6) for cuts, etc. and replace if required.
- D) Install new Dual Stage Element and tighten End Cap Retaining Nut. Be sure Element is seated squarely on Manifold boss and End Cap.
- E) Apply light film of petroleum jelly on Bowl's beveled edge to provide good seal between Bowl and "O"-Ring. HAND TIGHTEN ONLY.
- F) Guide Drain Tube back through hole in case bottom.
- G) Dispose of used Dual Stage Element according to local, state and federal regulations.

2. **THIRD/FOURTH STAGE CARTRIDGE REPLACEMENT**

- A) Loosen Bracket Screw (7) from Bracket (8) .
- B) Loosen the five Manifold Bolts (9) and remove the front two Bolts. Now slide out the Third (10) and Fourth (11) Stage Aluminum Tube Assemblies.
- C) Remove the End Cap (12) from Third Stage Aluminum Tube Assembly and slide old Third Stage Filter Cartridge (13) out of aluminum tube. Clean aluminum tube in mild soap and water, dry and install new Third State filter cartridge. Be sure the Flow Direction Arrow on Third Stage Filter Cartridge is pointing down. Remove End Sealing Label (14) and install new End Cap.
- D) Follow same procedure for the Fourth Stage Filter Cartridge (15) replacement as in step (C). Be sure the Flow Direction Arrow on Fourth Stage Filter Cartridge is pointing up. Also be sure to remove End Sealing Label before installing new End Cap.
- E) Now slide the Third and Fourth Stage Aluminum Tube Assemblies back in place and install the front two Manifold Bolts.
- F) Tighten Manifold Bolts in sequence from center outward to 100 inch-pounds (1.15 Kg-M). Repeat sequence and re-torque bolts to 250 inch-pounds (2.88 Kg-M).
- G) Dispose of used cartridges according to local, state and federal regulations.

3. FINAL CHECK AND CALIBRATION

- A) Pressurize system and check for leaks.
- B) Flush system with compressed air for five (5) minutes.
- C) Calibrate Carbon Monoxide Monitor as outlined in Monitor's Information Manual.

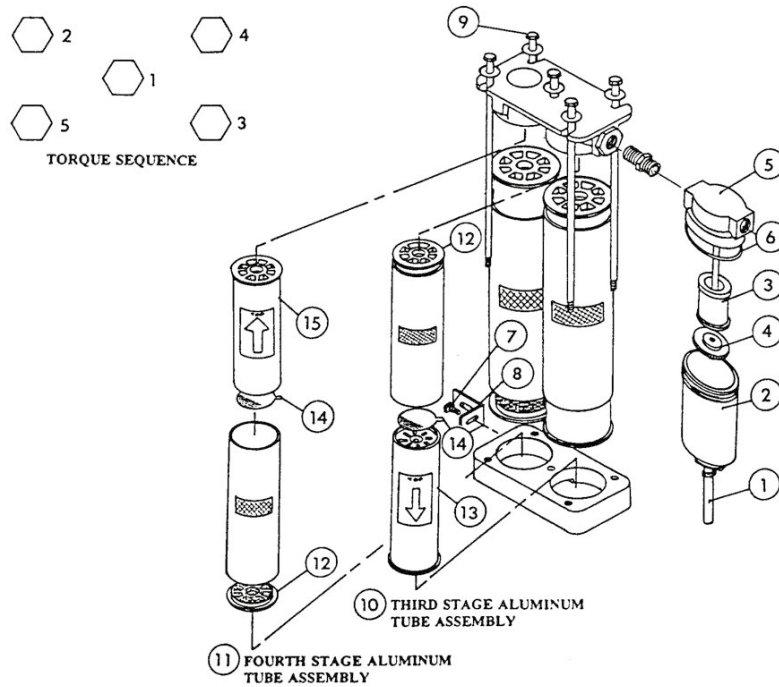

FIGURE NO. 2

8

**AIR SAMPLE TO  
MONITOR ADJUSTMENT**

\*\*\*\*\*  
**WARNING : SERIOUS INJURY** could result if the **AIR SAMPLE METERING VALVE** is not properly adjusted. Proper sample air flow to 'CO' monitor is required for monitor to give correct 'CO' level readout.  
 \*\*\*\*\*

**AIR SAMPLE METERING VALVE ADJUSTMENT**

- A) Pressurize system and set regulator for proper air flow to respirator(s).
- B) Adjust Air Sample Metering Valve's adjustment knob so the black floating ball is within the GREEN BOXED area etched on valve body. Proper air sample is now being metered to the 'CO' Monitor. Periodically check to be sure ball is floating in this area.

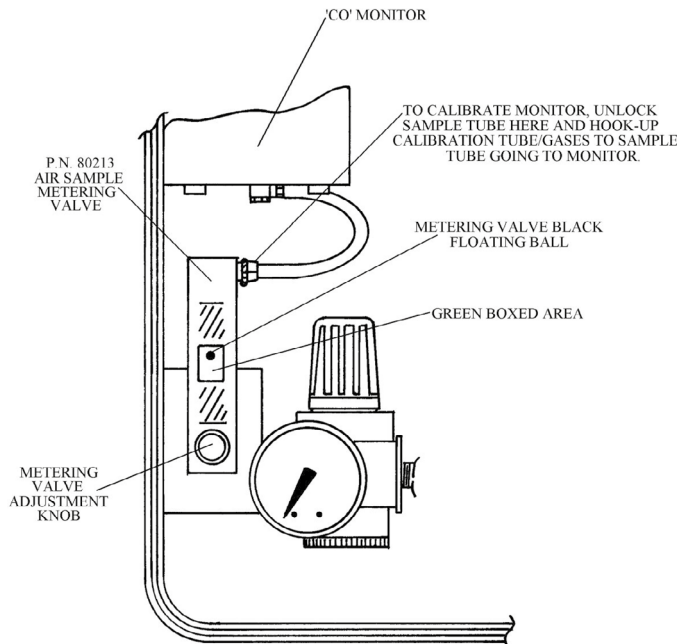

09/99



**RECORD KEEPING**

Record all periodical air quality checks, monitor calibration dates, filter cartridge change intervals and any other service performed on the Portable Air Panel.

**The Factory shall not be liable for any injury, loss or damage, direct or consequential, arising out of the use of or the inability to use this product, beyond the replacement of defective materials or workmanship. Users of supplied air respirators should evaluate their own particular application and perform their own tests for air quality to determine the suitability for use of this product.**

For further information, or questions about service or maintenance care of this unit, contact your local distributor or factory at (800) 542-6646.

10

**SERVICE RECORD**  
**PORTABLE AIR PANEL**  
**MODEL BA100BMST**

DATE OF SERVICE	SERVICE PERFORMED

## 11

**SPECIFICATIONS  
PORTABLE AIR PANEL  
MODEL BA100BMST**

INLET PRESSURE (MAX.)	150 PSIG STATIC (10.4 BAR)
RATED AIR FLOW (MAX.)	100 SCFM (47.2L/s)
OPERATING PRESSURE	100 PSIG DYNAMIC (6.9 BAR)
OUTLET PRESSURE RANGE	0-125 PSIG (0-8.6 BAR)
OPERATING TEMP. RANGE	35-150°F (2-65°C)
OUTSIDE DIMENSIONS	23.25"L X 20.75"W X 9"D (590mm X 527mm X 229mm)
WEIGHT (INCLUDING MONITOR)	36 LBS. (16.3 Kg.)
REPLACEMENT FILTER SET	FB100

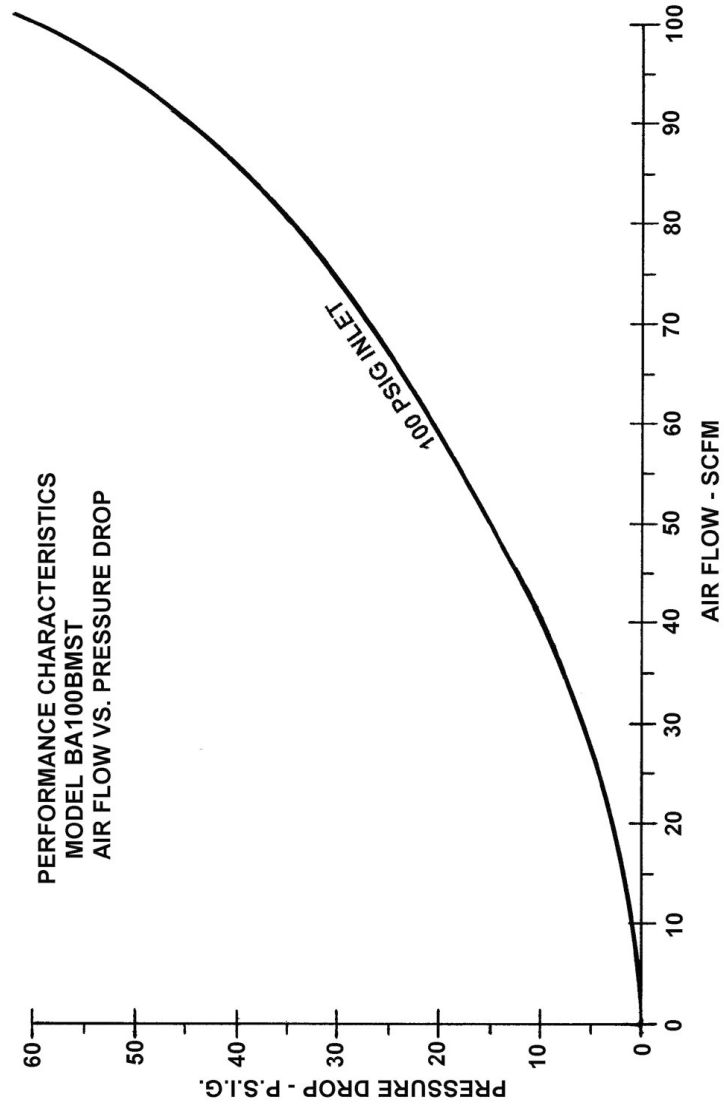

**PORTABLE AIR PANEL  
MODEL BA100BMST PARTS**

- |    |                                    |    |                                    |
|----|------------------------------------|----|------------------------------------|
| 1  | 80025, (1), Black Case             | 14 | 80009, (1), Manifold Bracket       |
| 2  | 80086, (1), Blue Inlet Block       | 15 | S006-148, (3), Bracket Bolts       |
| 3  | 80014, (1), Pressure Relief Valve  | 16 | S011-040, (5), Manifold Bolts      |
| 4  | S603-035, (3), Close Nipple - 3/4" | 17 | 12021, (5), Manifold Washers       |
| 5  | 80104, (1), Prefilter-100 SCFM     | 18 | 80118, (2), Tubing St. Elbow       |
| 6  | Drain Tube Clamp, (1)              | 19 | 80119-B, (1) Tubing                |
| 7  | S711-020, (1) Drain Tube           | 20 | 80075, (1), Regulator              |
| 8  | 80001, (1), Blue Base              | 21 | 80074, (1), Blue Outlet Block      |
| 9  | 80005, (1), Al Tube Third Stage    | 22 | S687-001, (2), Hex Plug - 1/8"     |
| 10 | 80005, (1), Al Tube Fourth Stage   | 23 | S603-001, (1), Close Nipple - 1/8" |
| 11 | 80114, (1), Base Bracket           | 24 | 80213, (1), Sample Metering Valve  |
| 12 | 80083, (1), Blue Manifold          | 25 | 80261,(1),Sampling Hose Connector  |
| 13 | 80127, (1), "CO" Monitor           | 26 | 80076, (1), Pressure Gauge, 0-160  |

