

Sundstrom SR200 Mask

MV2 VALVE®

OPERATION AND MAINTENANCE MANUAL
OCTOBER 2007



SAVE THIS MANUAL AND MAKE AVAILABLE
TO ALL USERS OF THIS EQUIPMENT!

Manual Part Number 7200-290



AXXIOM Manufacturing, Inc.
11927 S. Highway 6, Fresno, Texas 77545
800.231.2085 * 281.431.0581 * fax 281.431.1717



WARNING

- 1. Any person intending to operate this equipment or any person intending to be in the vicinity during its operation that cannot read or completely understand all of the warnings, operating procedures and instructions, and the rules for safer operation contained in this manual must receive proper training from their supervisor and/or employer. Consult Axxiom Manufacturing, Inc.**
- 2. Do not operate any abrasive blaster or blast equipment before reading and completely understanding all the warnings, operating procedures and instructions, and the rules for safer operation contained in this manual.**
- 3. Do not operate any abrasive blaster or blast equipment without following the rules for safer operation and all the operating procedures and instructions. Failure to properly use blast equipment could result in serious injury or death.**
- 4. Do not perform any maintenance while any abrasive blaster or blast equipment is pressurized. Always depressurize any vessel before loading media or performing any maintenance.**
- 5. Do not use abrasives containing free silica. Silica can cause silicosis or other related respiratory damage. You must wear personal protective equipment for all abrasive blasting operations. Observe all applicable local, state and federal safety regulations in conjunction with airline filters and respiratory protection. Reference OSHA (Occupational Safety and Health Administration).**
- 6. Do not enter areas during abrasive blasting operations without breathing protection. All personnel in the vicinity of abrasive blasting operations should wear NIOSH approved air fed respirators, hoods or helmets.**
- 7. Do not modify or alter any abrasive blaster, blast equipment or controls thereof without written consent from Axxiom Manufacturing, Inc.**
- 8. Do not use bleeder type deadman valves on any Schmidt® abrasive blasters. The use of A-BEC, Clemco or a similar bleeder type deadman valve can cause unintentional start-up without warning, which can result in serious personal injury.**
- 9. Do not sell, rent, or operate abrasive blasters without remote controls. OSHA regulations require remote controls on all blast machines. Failure to use remote controls can cause serious injury or death to the operator(s) or other personnel in the blasting area. (Reference OSHA regulations.)**
- 10. Do not repair or replace any portion of Schmidt equipment using components that are not Schmidt original replacement parts. Use of replacement components that are not Schmidt original replacement parts may result in equipment failure which can result in serious personal injury and will void all warranties.**

MV2 VALVE®		
	2127-107	MV2 Valve Assembly, 1 1/4"
	2127-108	MV2 Valve Assembly, 1 1/2"
No.	Part No.	Description
	2127-100-98	Replacement Parts Kit, Seals Only
	2127-100-99	Replacement Parts Kit
1.	2127-000-01	Knob
2.*	7011-005-06	Socket Head Cap Screw, 5/16" x 1" Lg. Self Sealing
3.	7010-507-06	Hex Bolt, 3/8" x 1" Lg.
5.*	2127-000-05	Plunger
6.	2127-000-06	Body
7.* + 2149-500-06		Plunger Seal
8.* + 2127-100-08		Polyurethane Sleeve
9.* + 2127-000-09		O-Ring
10.	2127-007-10	Base, 1 1/4"
	2127-008-10	Base, 1 1/2"
11.	7027-503-02	Flat Washer, 3/8"
12.* + 2127-000-12		Ball
13.	2127-000-13	Orifice Indicator Decal
14.	2127-000-14	Cleanout Ball Valve Adder
15.	2401-505	Ball Valve, 3/4" Full Port
16.	3006-105	Street Elbow 90°, 3/4" Galv.
17.	3037-105	Pipe Cap, 3/4" Galv.
* Included in Replacement Parts Kit		
+ Included in Replacement Parts Kit, Seals Only		

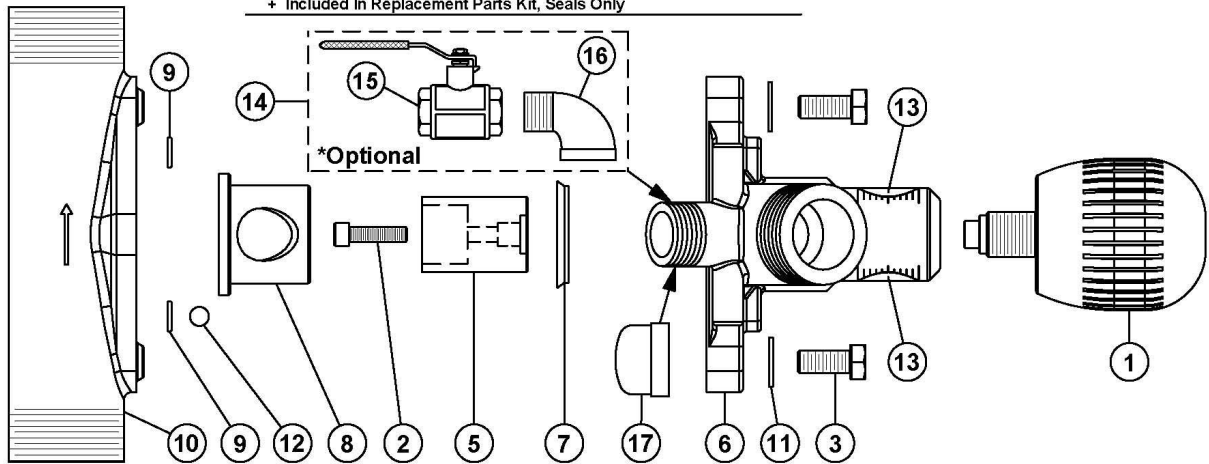

1.0. RULES FOR SAFER OPERATION

- 1.1. **KNOW YOUR EQUIPMENT.** Do Not operate this equipment in a manner other than its intended application (see Section 2.0). Do Not operate this equipment without following the *Rules for Safer Operation* and all the operating procedures. Failure to do so could result in serious injury or death.
- 1.2. **RECEIVE PROPER TRAINING.** Do Not operate or perform maintenance on this equipment unless you have received operational and maintenance training. Begin by thoroughly reading and understanding this document and any operational and maintenance manual or instructions for the equipment that will be used in conjunction with the MV2 Valve®. Consult an authorized Schmidt® or Axxiom distributor.
- 1.3. **USE PROPER PERSONAL PROTECTIVE EQUIPMENT.** Do Not operate or perform maintenance on this equipment without wearing OSHA approved eye, ear, foot, and lung protection.
- 1.4. **ADHERE TO ALL REGULATIONS.** Do Not operate or perform maintenance on this equipment without observing all local, state, and federal safety regulations including, but not limited to, OSHA (Occupational Health and Safety Administration).
- 1.5. **USE CORRECT REPLACEMENT PARTS.** Do Not use replacement parts that are not manufactured by Axxiom Manufacturing, Inc. and furnished by an authorized distributor of Axxiom Manufacturing, Inc. Incorrect replacement parts can result in equipment failure and cause serious injury or death.
- 1.6. **SAVE THIS OPERATION AND MAINTENANCE MANUAL.** refer to this operation and maintenance manual as well as any other manufacturers information included for equipment that is used in conjunction with the MV2 Valve. Never permit anyone to operate this equipment without having him/her first read this manual and receive proper training. Provisions should be made to have this manual readily available to the operating and maintenance personnel. If for any reason the manual becomes lost or illegible, have it replaced immediately. This operation and maintenance manual should be read periodically to maintain the highest skill level; it may prevent a serious accident.

2.0 GENERAL INFORMATION

- 2.1 The MV2 Valve® is designed to be used in a depressurized blast system; meaning that the blast tank is depressurized each time the remote control deadman is released. The MV2 Valve is best used in conjunction with a Combo Valve® and a G2 Deadman valve to form a depressurized blast system. Consult an authorized Schmidt distributor or Axiom Manufacturing, Inc. for system compatibility verification.
- 2.2 The MV2 Valve installed in an abrasive blast control system allows metering of the abrasive flow during the blast operation. Rotate the knob (#1) clockwise to decrease media flow or counter clockwise to increase media flow.
- 2.3 The orifice indicator decal (#13) located on each side of the MV2 Valve body (#6) allows the operator to see the orifice size. The portion of the orifice indicator decal (#13) uncovered by the knob (#1) represents the exact size and shape of the orifice.

3.0 DISASSEMBLY (refer to drawing on facing page)

- (Tools required: 9/16" wrench, 1/4" allen wrench)
- 3.1 Remove the two 3/8" bolts (#3) and flat washers (#11) using a 9/16" wrench.
- 3.2 Remove the base (#10) from the body (#6). Be careful not to loose the ball (#12) and two o-rings (#9).
- 3.3 Rotate knob (#1) clockwise until it stops.
- 3.4 Remove the socket head cap screw (#2) using a 1/4" allen wrench.
- 3.5 Remove the plunger (#5), sleeve (#8) and plunger seal (#7) from body (#6).
- 3.6 Do not remove any screw plugs from the MV2 body.
- 3.7 Discard all the parts that will be replaced with parts from the replacement parts kit.

4.0 REASSEMBLY

- 4.1 Clean interior cavity of the body (#6) removing all debris.
- 4.2 Check body (#6) and base (#10) for cracks or other defects. Replace if necessary.
- 4.3 Screw the knob (#31) into the body (#6) until it stops. Then back it out two turns.
- 4.4 Slide plunger seal (#7) onto plunger (#5) with o-ring side of seal towards bottom of plunger (#5).
- 4.5 Insert plunger (#5), with plunger seal (#7) installed, into body (#6) until it stops against knob bolt (#1).
- 4.6 While pressing the plunger (#5) into body (#6), turn the knob (#1) until the knob bolt locks into the socket of plunger (#5).
- 4.7 Install socket head cap screw (#2) using a 1/4" allen wrench.
- 4.8 Rotate knob (#1) counter clockwise until plunger (#5) is flush with bottom of the body (#6).
- 4.9 Insert sleeve (#8) into body (#6), making sure flat on sleeve (#8) lines up with flat on body (#6).
- 4.10 Install the two o-rings (#9) into base (#10).
- 4.11 Place ball (#12) into the orifice on the inlet side of base (#10).
- 4.12 Connect base (#10) to body (#6) with two 3/8" bolts (#3) and flat washers (#11) using a 9/16" wrench.

5.0 INSTALLATION

- 5.1 Screw media inlet of MV2 Valve into media outlet of abrasive blaster vessel.
- 5.2 Install threaded hose coupling on outlet side of MV2 Valve base (#10).
- 5.3 Connect the swivel fitting of the air hose to the inlet side of MV2 Valve base (#10).
- 5.4 Follow the setup and pre-operating instructions provided with the blast system, and then test the operation of the MV2 Valve.
- 5.5 Check for air leaks at all the connections repair as required.

6.0 MAINTENANCE AND INSPECTION

- 6.1 The MV2 Valve should be disassembled and inspected quarterly, or more frequently for heavy usage. Replace parts as needed with Schmidt® original factory replacement parts furnished by an authorized Schmidt distributor.

⚠ DANGER

Depressurize vessel before performing any maintenance. Removing the MV2 Valve bolts with the abrasive blaster pressurized will result in serious injury or death.

7.0 TROUBLESHOOTING

- 7.1 Air blasts with no abrasive
- (1) Check abrasive level in the blast vessel even if one outlet continues to blast normally.
 - (2) MV2 Valve abrasive adjustment knob (#1) is closed. Rotate knob counter clockwise to increase media flow.
 - (3) Trash plugging opening from tank to MV2 Valve.
- 7.2 Abrasive choking out of blast hose with low blast air pressure.
- (1) MV2 Valve abrasive adjustment knob (#1) is open too far. Rotate knob clockwise to decrease media flow.
- 7.3 Reduced pressure at the nozzle (with or without abrasive flow)
- (1) MV2 Valve abrasive adjustment knob (#1) is open too far.
- 7.4 If problems persist, consult blaster operation and maintenance manual for further troubleshooting procedures.

8.0 TRADEMARKS, PATENTS, AND PROPRIETARY STATEMENTS

Schmidt, the Schmidt S logo, MV2 Valve, Thompson Valve, and ComboValve are registered trademarks owned by Axiom Manufacturing, Inc. Use of these trademarks without the written consent of Axiom Manufacturing is strictly prohibited. Products manufactured and marketed by Axiom Manufacturing, Inc. are protected by patents issued or pending in the United States and other countries. The text, diagrams, and drawings contained in this manual are proprietary information intended solely for instruction in the operation of the specified equipment. Use of any text, diagrams, or drawings contained in this manual for any reason other than its intended purpose without the written consent of Axiom Manufacturing, Inc. is strictly prohibited.