

23:1 MONARK CARBON STEEL, CART MOUNTED

AA200hs Air-Assisted Airless Spray Package

See the Data Sheet, 305—663, for application information.

2760 psi (190 bar) Maximum System Working Pressure
120 psi (8.3 bar) Maximum Air Inlet Pressure

Model 237—418, Series A

This complete package includes a pump, an AA200hs air-assisted airless—spray gun with a 411 spray tip, a portable cart, 25 ft. (7.6 m) air and fluid hoses, air and fluid controls, and a fluid feed.

IMPORTANT

This manual provides the basic safety, installation and operation information for the package. For your safety, also read the component manuals supplied with this package before operating it.

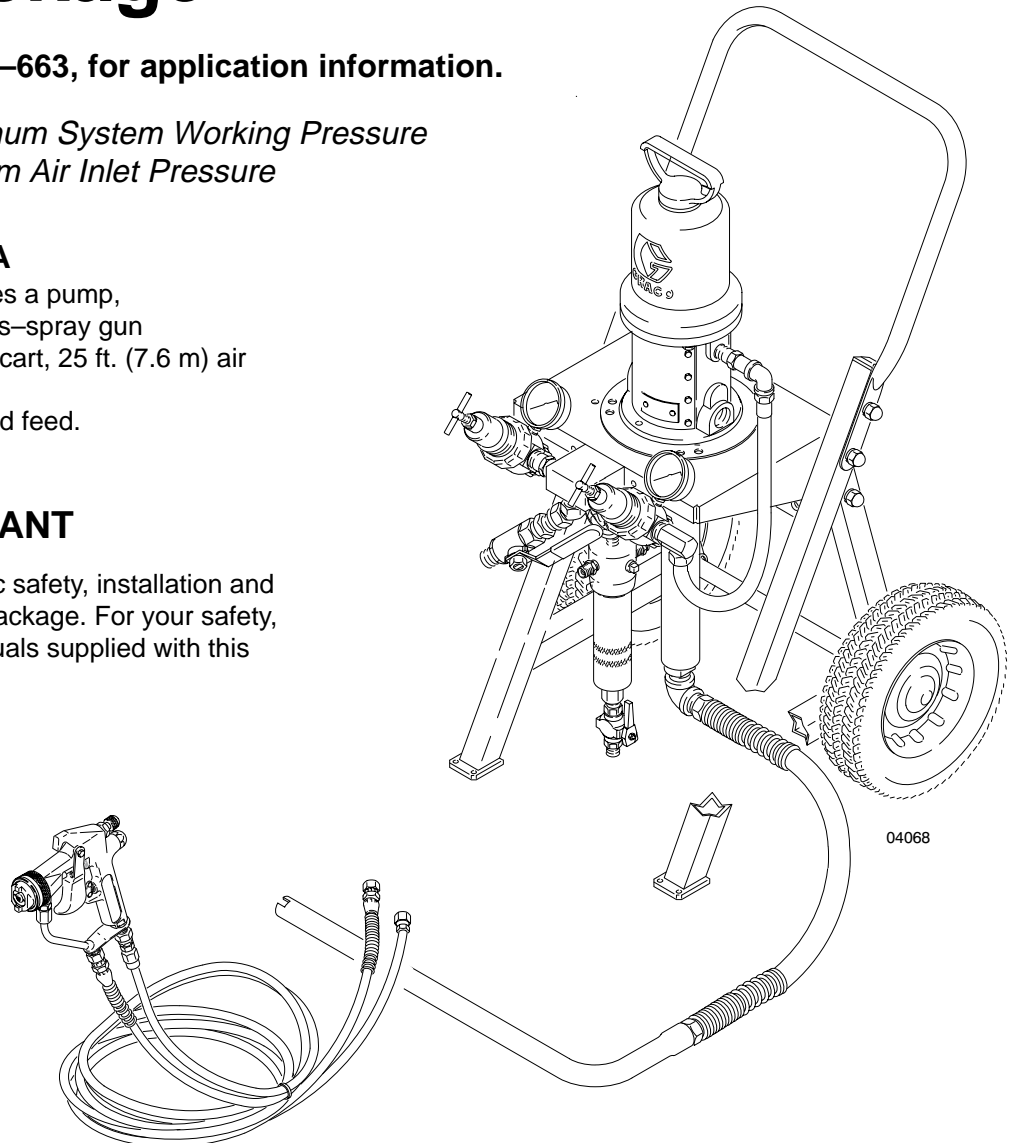

Table of Contents

Symbols	2
Warnings	3
Setup	5
Ground the system	6
System Component Information	7
Operation	8
Pressure relief procedure	8
Flushing	10
Parts	12
Technical Data	16
Warranty	16
Graco Phone Numbers	16

Symbols

Warning Symbol



This symbol alerts you to the possibility of serious injury or death if you do not follow the instructions.

Caution Symbol



This symbol alerts you to the possibility of damage to or destruction of equipment if you do not follow the corresponding instructions.

WARNING



INJECTION HAZARD

Spray from the gun, hose leaks or ruptured components can inject fluid into your body and cause extremely serious injury, including the need for amputation. Splashing fluid in the eyes or on the skin can also cause serious injury.

- Fluid injected into the skin is a serious injury. The injury might look like just a cut, but it is a serious injury. Get immediate medical attention.
- Do not point the spray gun at anyone or any part of the body.
- Do not put hand or fingers over the spray tip.
- Do not stop or deflect fluid leaks with your hand, body, glove or rag.
- Do not “blow back” fluid; this is not an air spray system.
- Always have the tip guard and the trigger guard on the spray gun when spraying.
- Check the gun diffuser operation weekly. Refer to the gun manual.
- Be sure the gun trigger safety operates before spraying the gun.
- Lock the gun trigger safety when you stop spraying.
- Follow the **Pressure relief procedure** on page 8 if the spray tip clogs and before cleaning, checking or servicing the equipment.
- Tighten all fluid connections before each use.
- Check the hoses, tubes and couplings daily. Replace worn or damaged parts immediately. Permanently coupled hoses cannot be repaired.
- Handle and route hoses and tubes carefully. Keep hoses and tubes away from moving parts and hot surfaces. Do not use the hoses to pull equipment. Do not expose Graco hoses to temperatures above 180°F (82°C) or below -40°F (-40°C).



TOXIC FLUID HAZARD

Improper handling of hazardous fluids or inhaling toxic fumes can cause extremely serious injury, even death, due to splashing in the eyes, ingestion, or bodily contamination.

- Know the specific hazards of the fluid you are using.
- Store hazardous fluid in an approved container. Dispose hazardous fluid according to all local, state and national guidelines.
- Wear appropriate clothing, gloves, eyewear and respirator.

WARNING



FIRE AND EXPLOSION HAZARD

Improper grounding, poor air ventilation, open flames or sparks can cause a hazardous condition and result in a fire or explosion and serious injury.



- Ground the equipment and the object being sprayed. See **Ground the system** on 6.
- If there is any static sparking while using the equipment, **stop spraying immediately**. Identify and correct the problem.



- Provide fresh air ventilation to avoid the buildup of flammable vapors from solvent or the fluid being sprayed.



- Do not smoke in the spray area.
- Extinguish all open flames or pilot lights in the spray area.



- Do not turn on or off any light switch in the spray area.
- Electrically disconnect all equipment in the spray area.
- Keep the spray area free of debris, including solvent, rags and gasoline.
- Do not operate a gasoline engine in the spray area.



INSTRUCTIONS

EQUIPMENT MISUSE HAZARD

Equipment misuse can cause the equipment to rupture, malfunction or start unexpectedly and result in serious injury.

- This equipment is for professional use only.
- Read all instruction manuals, tags, and labels before operating the equipment.
- Use the equipment only for its intended purpose. If you are in doubt about this, call Graco Technical Assistance at 1-800-543-0339.
- Do not alter or modify this equipment. Use only genuine Graco parts and accessories.
- Check equipment daily. Repair or replace worn or damaged parts immediately.
- Do not exceed the **2760 psi (190 bar) maximum working pressure at 120 psi (8.3 bar) maximum incoming air pressure** of the pump, or the maximum working pressure of any accessory used with it.
- Do not move or lift pressurized equipment.
- Use fluids or solvents which are compatible with equipment wetted parts. Refer to the **Technical Data** section of all equipment manuals. Read the fluid and solvent manufacturer's warnings.
- Fluid hoses must have spring guards on both ends to protect it from rupture caused by kinks or bends at or close to the couplings.
- Comply with all applicable local, state and national fire, electrical and other safety regulations.
- Do not touch the heater during operation; it is very hot.



MOVING PARTS HAZARD

Moving parts, such as the air motor piston located behind the air motor plates, which can pinch or amputate fingers.

- Never operate the equipment with the air motor plates removed.
- Keep clear of any moving parts when starting or operating the equipment.

Setup

I. Prepare the operator.

All persons who operate the system should be trained in the safe, efficient operation of all system components as well as the proper handling of the chemical coating. At a minimum, all operators should thoroughly read the safety, installation and operation sections of this manual and the component manuals.

II. Prepare the site.

1. Use a minimum recommended 5 HP (3.7 kW) air compressor for efficient operation.
2. Clear obstacles and debris that could hinder the operator's movement.
3. Bring an air line from your compressed air supply to the pump location. Be sure the air is dry and filtered. Install a bleed-type master air valve (A) upstream from the pump. Another master air valve (14) is supplied with the package. When the bleed-type master air valve is closed and the pump air regulator (8a) is opened, the valve relieves all air pressure to the system.

4. Have a grounded, metal waste-pail available to use when draining the fluid filter.
5. Ventilate the spray booth.

⚠ WARNING

To prevent hazardous concentrations of toxic and/or flammable vapors, spray only in a properly ventilated spray booth. **Never operate the spray gun unless ventilation fans are operating.**

Check and follow all of the national, state and local codes regarding air exhaust velocity requirements.

KEY

Components you must supply:

- A Bleed-type master air valve
Required for pump; order part no. 107-142, 1/4" npt(f)
- B Air filter. Order part no. 106-149, 1/2 npt(f)
- C Air supply line
- D Grounded 5 gallon metal pail
- E Air line moisture trap

Components supplied with package:

- 1 23:1 Monark pump
- 3 Air-assisted airless spray gun
- 4 Spray tip
- 6 Gun fluid hose
- 7 Gun air hose
- 8a Pump air regulator
- 8b Gun air regulator
- 14 Bleed-type air valve
- 30 Pump ground wire

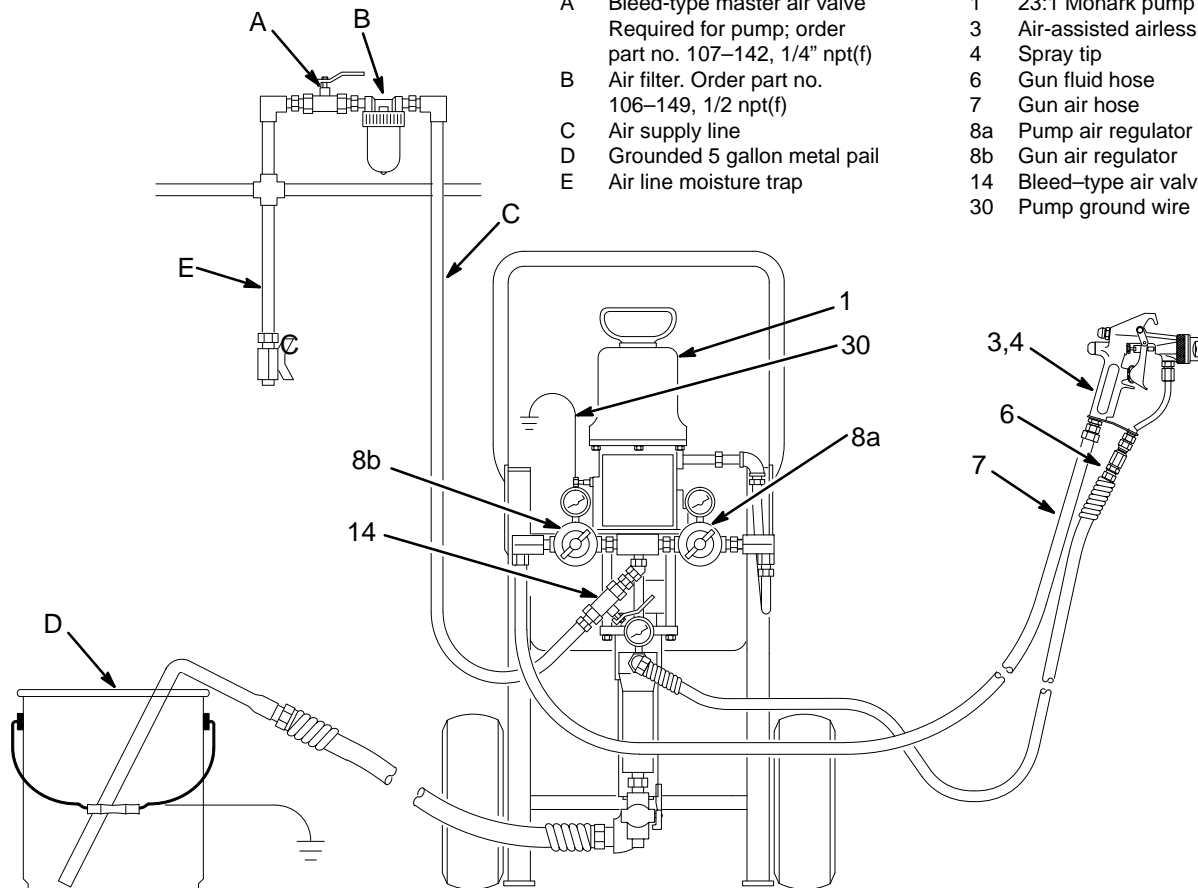

Fig. 1

04072

Setup

III. Unpack the system.

1. In addition to the assembled components, the air and fluid hoses, gun and instruction manuals are packaged separately in the main shipping container. These are the manuals you should receive:

307-619 23:1 ratio Monark pump
308-176 Air-assisted airless spray gun
307-273 Fluid filter
308-167 Air regulator
308-861 Ball valve

IV. Connect the hoses and gun to the system. See Fig. 1.

1. Connect the blue fluid hose (6) between the fluid filter and the fluid inlet of the spray gun (3). These are 1/4-18 npsm(f) swivel fittings.
2. Connect the red air hose (7) between the gun air regulator (8b) and the air inlet of the spray gun (3). These are 1/4-18 npsm(f) swivel fittings.
3. Verify that all fittings throughout the system are tightened securely.

V. Ground the system.

WARNING

To reduce the risk of static sparking, ground the pump and all other equipment used or located in the spray area. Check your local electrical code for detailed grounding instructions for your area and type of equipment. *Ground all of this equipment.* Also read **FIRE OR EXPLOSION HAZARD** on page 4.

1. *Pump*: one end of the ground wire (30) is already connected to the air motor grounding lug. Connect the clamp end of the ground wire to a true earth ground.
2. *Air and fluid hoses*: use only electrically conductive hoses with a maximum of 500 feet (150 m) combined hose length to ensure grounding continuity.
3. *Air compressor*: according to manufacturer's recommendations.
4. *Fluid supply container*: according to local code.
5. *All solvent pails used when flushing*, according to local code. Use only metal pails, which are conductive. Do not place the pail on a non-conductive surface, such as paper or cardboard, which interrupts the grounding continuity.

System Component Information

I. How to use the air-assisted airless spray gun.

With an air-assisted airless spray gun, the spray tip shapes the fluid into a fan pattern. Air from the air cap further atomizes the fluid and completes the atomization of the paint tails into the pattern to produce a more uniform pattern.

The spray gun has a built-in lead and lag operation. When triggered, the gun emits air before the fluid is discharged. When the trigger is released, the fluid stops before the air flow stops. This helps assure the spray is atomized and prevents fluid buildup on the air cap.

NOTE: The gun air and fluid inlets have 1/4–18 npsm (R1/4–19) compound male threads that are compatible with NPSM and BSP female swivel connectors.

1. The fan pattern valve (E) can be used to reduce the pattern by about 25% of the total pattern width. As the valve is opened, the pattern will reduce slightly. The tip used designates the total width of the spray pattern.
2. To unlock the gun trigger safety, turn the safety so it is parallel with the trigger. To lock the gun trigger safety, turn the safety to a right angle with the trigger. See Fig. 2.

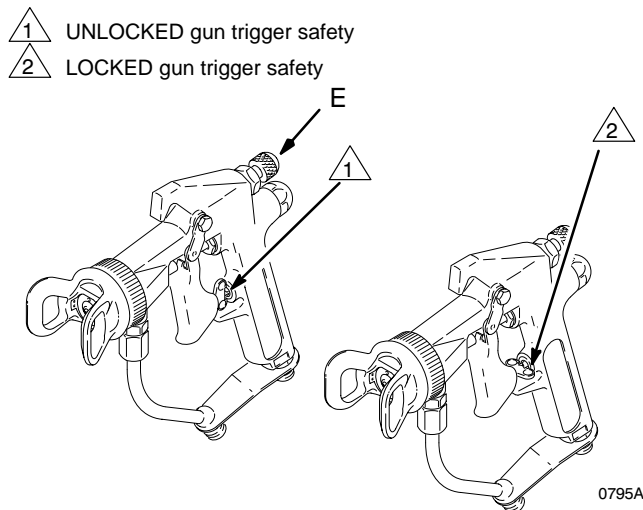

Fig. 2

0795A

II. How to change the spray pattern direction.

1. Relieve the air and fluid pressure.
2. Install a spray tip in the gun. Rotate the air cap (the spray tip rotates with it) to determine the direction of the spray pattern. See Fig. 3.

Vertical Spray Pattern

Horizontal Spray Pattern

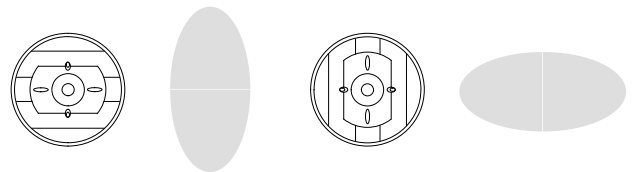

Fig. 3

0791

III. How to adjust the air regulators.

See Fig. 4.

As you look at the system, the air regulator (8a) on the left regulates air to the gun and the air regulator (8b) on the right regulates air to the pump.

1. Always open air regulators slowly to prevent surging during startup.
2. To open the regulator, which allows air to flow, turn the T-handle IN (clockwise). Turn the T-handle OUT (counterclockwise) to close off the air flow. Be sure the jam nut under the T-handle does not interfere with your adjustments. Tighten the jam nut to lock in the setting, if desired.

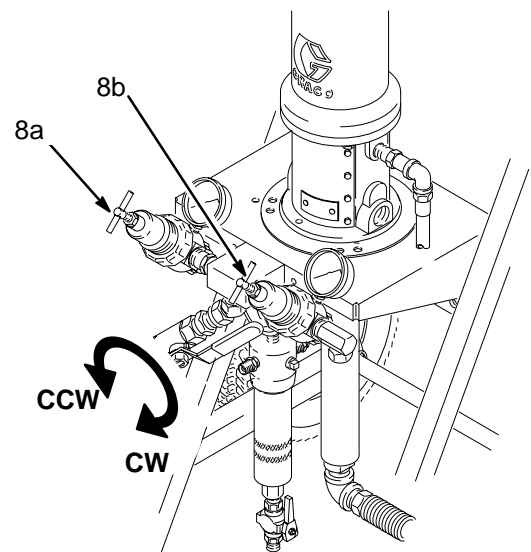

Fig. 4

04069

Operation

I. Pressure relief procedure

⚠ WARNING

The system remains pressurized until pressure is manually relieved. To reduce the risk of serious injury, including skin injection from pressurized fluid or accidental spray from the gun, or injury due to splashing fluid in the eyes or on the skin, follow this procedure whenever you:

- are told to relieve pressure;
- stop spraying;
- check or service any system equipment;
- install, clean or change spray tips.

1. Lock the gun trigger safety.
2. Close the bleed-type master air valves (A,14).
3. Close the air regulators (8a,8b).
4. Unlock the gun trigger safety.
5. Hold the gun firmly against a grounded metal waste pail. Trigger the gun to relieve pressure.
6. Lock the gun trigger safety.
7. Open the filter drain valve (26), having a container ready to catch the drainage. Close the drain valve.

If you suspect that the spray tip or hose is completely clogged or that pressure has not been fully relieved, very slow loosen the tip retaining nut or hose end coupling and relieve pressure gradually. Clean the tip or hose obstruction.

II. Flush the pump before the first use.

Flush with a solvent compatible to your fluid. Consult the fluid manufacturer's literature for recommendations. See **Flushing** on page 10.

III. Prime the system.

See Fig. 5.

1. Remove the air cap and spray tip from the gun.
2. Close the filter drain valve (26).
3. Put the suction tube into the fluid supply container.
4. Make sure the air regulators (8a,8b) are closed.
5. Open the master air valves (A,14).

NOTE: In the next steps, the pump will cycle quickly until air is purged.

6. Slowly turn on the pump air regulator (8a) until the pump cycles slowly.
7. Hold a metal part of the gun firmly against and aimed into the grounded metal waste pail. Trigger the gun while increasing pressure at the pump air regulator (8a) just enough to purge the air and storage solvent from the system. When new fluid comes from the gun, release the trigger. Lock the gun trigger safety.

KEY

- A Bleed-type master air valve
- 3 Air-assisted airless spray gun
- 8a Pump air regulator
- 8b Gun air regulator
- 14 Bleed-type air valve
- 26 Filter drain valve

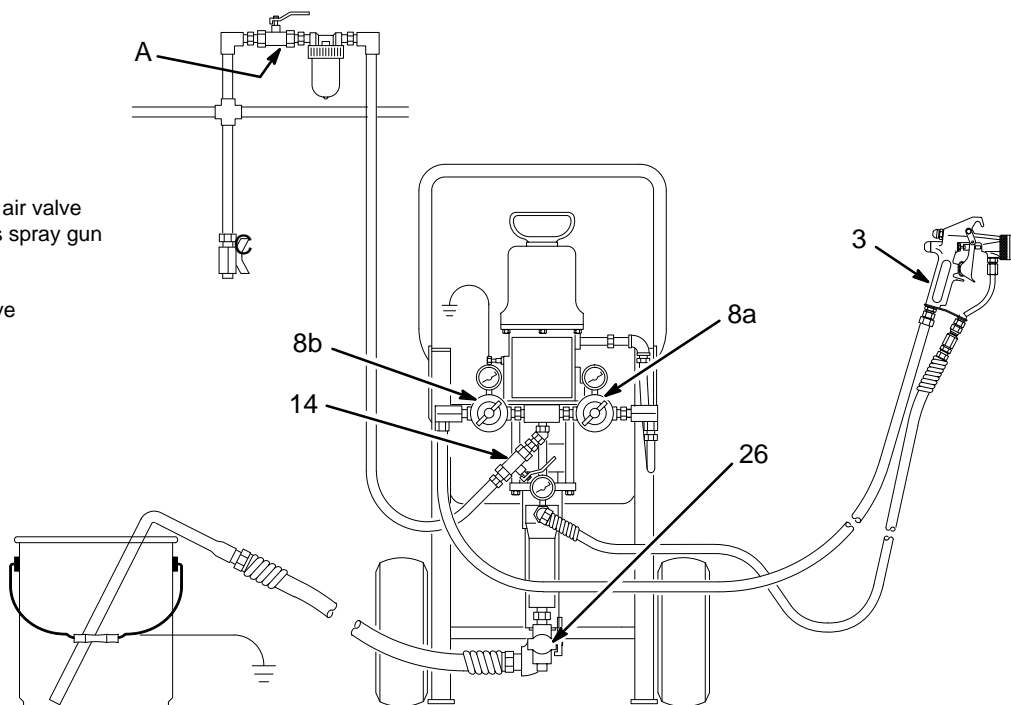

Fig. 5

04072

Operation

IV. Set the fluid and air pressure.

1. Install the spray tip and air cap on the gun.
2. Adjust the pump air pressure regulator until the pressure shown on the fluid filter gauge is about 800 psi (56 bar). This should require approximately 35 psi (2.4 bar) air pressure to the pump.
3. Test spray a pass or stationary horizontal pattern. Hold the gun 10 to 12 in. (250 to 300 mm) from the paper. Stripes in the outer edges of the pass or spots at the ends of the stationary pattern are likely at this point.

NOTE: If there are no stripes or spots, lower the fluid pressure until they appear *before* turning on the air to the gun.

4. Partially trigger the gun so only air is emitted. Set the gun air regulator to 20 psi (1.4 bar).
5. Retest the spray pattern. Trigger the gun and adjust the gun's air control valve (C) to add air to the aircap and to eliminate stripes or spots. If there are no stripes or spots, you are ready to start spraying.
6. If there are stripes or spots in the spray pattern, raise the pump air pressure until you raise the fluid outlet pressure by about 100 psi (6.9 bar) and try again. Continue to raise the fluid pressure in 100 psi (6.9 bar) increments until the pattern is full and clean. Do not exceed 120 psi (8.3 bar) incoming air pressure or 2760 psi (190 bar) fluid working pressure.

NOTE: Always use the lowest fluid and air pressure required for good atomization and spray pattern for maximum fluid efficiency. Air pressure over approximately 30 psi (2.1 bar) will cause turbulence in the fan pattern, dirty air caps and slower production capability.

V. You are now ready for production spraying.

CAUTION

When using catalyzed fluids, observe the pot life as recommended by the fluid manufacturer. Always flush the system before the pot life has expired to prevent dried fluid which may be difficult to clean out and may damage the system.

VI. When to shut down the system.

Shut down the system at the end of the work shift and before checking, adjusting, cleaning or repairing the system. Always follow the **Pressure relief procedure** on page 8.

WARNING

This system has a maximum air working pressure of 120 psi (8.3 bar) which produces a maximum fluid working pressure of 2760 psi (190 bar). Higher pressure can cause the system to rupture or malfunction and result in serious injury.

Flushing

I. When to flush.

- Before the first time use
- When changing colors
- Before fluid can dry or settle out in a dormant system (observe the recommended fluid pot life on catalyzed fluids)
- Before storing the system

II. How to flush.

See Fig. 6.

1. Relieve pressure. See page 8.
2. Remove the air cap and spray tip before flushing.
3. Unscrew the fluid filter (5) bowl. Remove the screen. See manual 307–273. Reinstall the bowl without the screen.
4. Put the suction tube into a grounded metal pail with about 1/2 gallon (2 liters) of a compatible solvent.
5. Make sure the air regulators (8a,8b) are closed.

NOTE: The gun air regulator (8b) always stays closed during flushing.

6. Open the master air valves (A,14).

7. Slowly turn on the pump air regulator (8a) until the pump cycles slowly.
8. Hold a metal part of the gun firmly against the grounded metal waste pail. Trigger the gun. Slowly increase the pump air regulator setting until the fluid flows freely. (Some air will spit from the gun until the fluid arrives.)
9. Keeping the gun triggered, decrease the pump air regulator (8a) pressure as much as possible without stalling the pump, and pump out the solvent until air comes through the gun.
10. Repeat the procedure with clean solvent, if needed.
11. Release the trigger and lock the gun trigger safety.
12. Close the master air valves (A,14). Fully close the pump air regulator (8a).
13. Open the drain valve (26), having a container ready to catch the drainage.
14. Remove the suction hose from the solvent and place it in an empty container.
15. Clean the filter screen, air cap and spray tip separately. Reinstall the filter screen.
16. Thoroughly clean the inside and outside of the suction tube.

KEY

- A Bleed-type master air valve
- 3 Air-assisted airless spray gun
- 5 Fluid filter
- 8a Pump air regulator
- 8b Gun air regulator
- 14 Bleed-type air valve
- 26 Filter drain valve

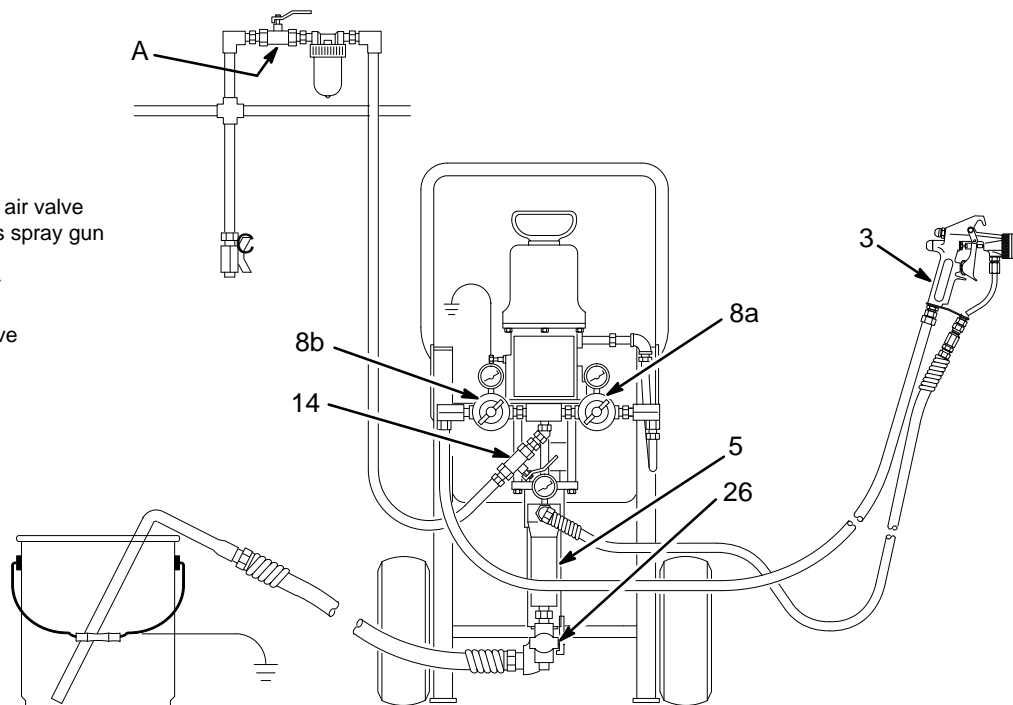

Fig. 6

04072

Parts

Model 237–418, Series A

Includes items 1 to 37

Ref No.	Part No.	Description	Qty	Ref No.	Part No.	Description	Qty
1	223–596	23:1 RATIO MONARK PUMP See 307–619 for parts	1	20	100–349	FLUID INTAKE ELBOW, 3/4 npt(f)	1
2	224–044	CART, portable See 308–136 for parts	1	21	100–016	LOCKWASHER, 1/4" spring	2
3	223–283	AIR ASSISTED AIRLESS SPRAY GUN See 308–176 for parts	1	23	155–665	SWIVEL UNION, 3/8 npt(m) x 3/8 npsm(f)	1
4	182–411	SPRAY TIP, 0.011 orifice, 8–10" (203–254 mm) fan width	1	24	206–994	THROAT SEAL LIQUID, 8 oz.	1
5	218–029	FLUID FILTER See 307–273 for parts	1	25	156–849	NIPPLE, 3/8 npt x 3/8–18.6 sf	1
6	214–698	FLUID HOSE, 3/16" x 25' (15.2 m), nylon, spring guards both ends, 1/4–18 npsm(fbe)	1	26	210–658	BALL VALVE, 3/8 npt (mbe), see 306–861 for parts	1
7	210–867	AIR HOSE, cpld 1/4 npsm (fbe) 1/4" ID x 25' (6.3 mm ID x 7.6 m)	1	27	156–877	NIPPLE, 1/2 npt, 2.5" (63.5 mm)	2
8	104–267	AIR REGULATOR 0–125 psi (0–9 bar) range See 308–167 for parts	2	28	188–595	PUMP MOUNTING PLATE	1
9	101–180	AIR PRESSURE GAUGE 0–200 psi (0–14 bar)	2	29	102–254	SCREW, hex hd, 1/4–20 x 7/8" (22 mm) long	2
10	161–037	90° SWIVEL ADAPTER UNION 1/2 npt(m) x 3/8 npsm(f) swivel	1	30	237–569	GROUND WIRE and CLAMP 12 gauge (1.5 mm ²), 25' (7.6 m)	1
11	204–560	AIR HOSE, buna-N, 3/8" (10 mm) ID, cpld 3/8 npt(mbe), 18" (457 mm) long	1	31	150–286	ADAPTER	1
12	222–297	45° SWIVEL ADAPTER UNION, 1/2 npt(m) x 1/2 npsm(f) swivel	1	32	165–472	ELBOW, 90°; 3/8 npt (fbe)	1
13	158–491	NIPPLE, 1/2 npt, 1.625" (41 mm) long	1	33	100–509	PLUG, 1/4 npt sq hd pipe	3
14	107–142	BLEED–TYPE AIR VALVE, 1/2 npt (f)	1	34	179–749	AIR MANIFOLD, 1/2 npt inlet, two 1/2 npt outlets	1
15	102–814	FLUID PRESSURE GAUGE	1	35	100–015	NUT, hex; 1/4–20	2
16	166–999	ELBOW, reducing street, 1/2 npt(m) x 1/4 npt(f)	1	36	100–840	ELBOW; 1/4 npt (m x f)	1
17	162–453	NIPPLE, 1/4 npt x 1/4 npsm	2	37	160–790	NIPPLE	1
18	214–960	SUCTION HOSE, 3/4 npt (mbe), 3/4 " ID x 3.5' (19 mm ID x 1.06 m)	1				
19	165–767	SUCTION TUBE, 3/4 npt(f)	1				

Manual Change Summary

This manual was updated to correct the parts drawing on page 13. The following parts lists changes were also made.

Assembly Changed	Part Status	Ref No.	Part No.	Name
237–418 Package	Add	31	150–286	Adapter
	Old	37	150–286	Nipple
	New	37	160–790	Nipple

Parts

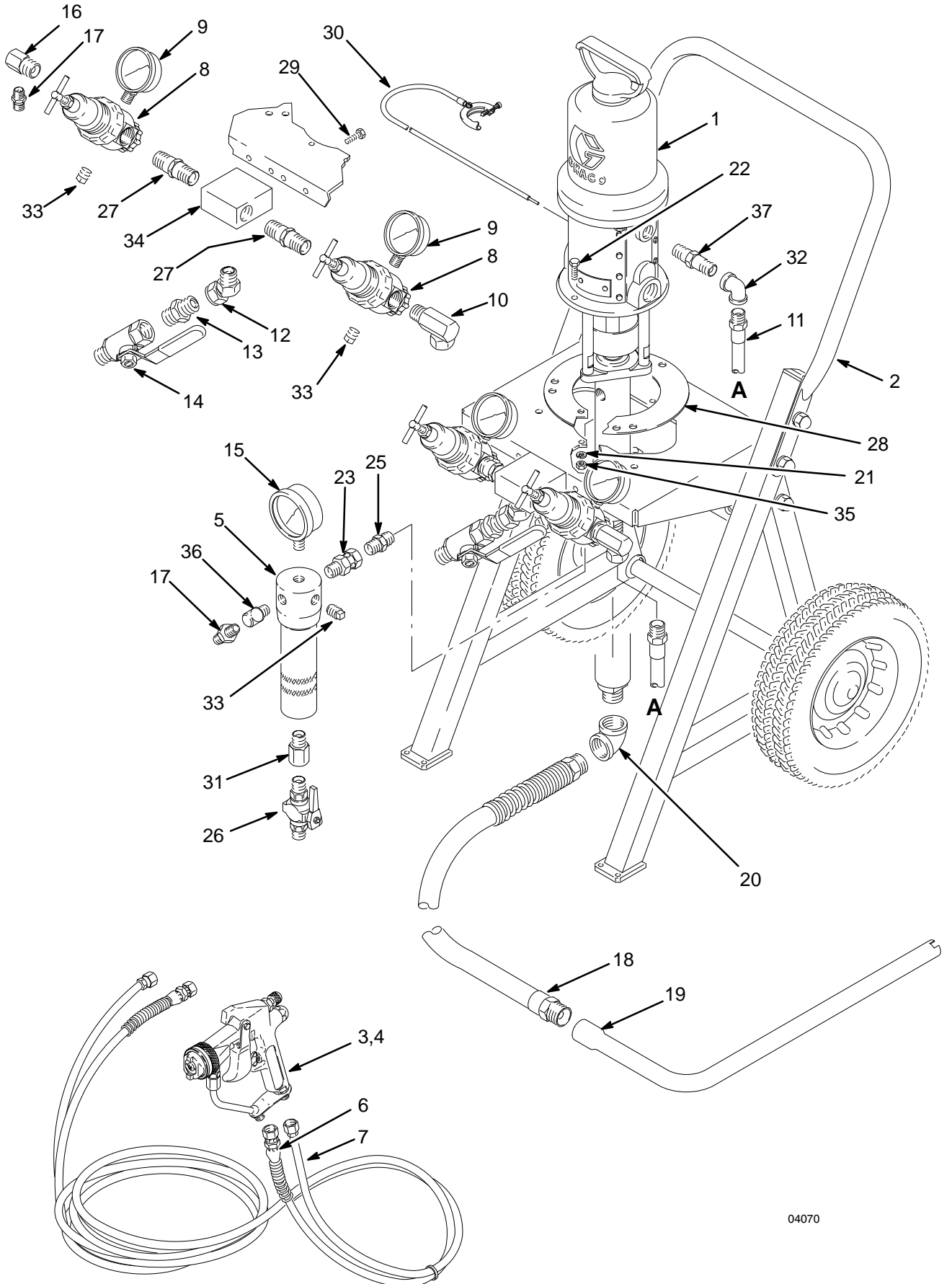

04070

Technical Data

Maximum Fluid Working Pressure 2760 psi (190 bar)
Maximum Air Operating Pressure 120 psi (8.3 bar)
Pump Air Consumption . . . *free flow*: 20 scfm at 100 psi (0.56 m³/min at 6.9 bar)
Gun Air Consumption 5 scfm at 30 psi (0.14 m³/min at 2.1 bar)
Wetted Parts

Pump carbon steel, 304/316/420/17-4 pH stainless steel,
chrome, chrome and zinc plating,
tungsten carbide, PTFE, leather
Gun 303 stainless steel, carbide, UHMWPE CV75,
polyethylene, PTFE, Delrin®
Fluid filter carbon steel, PTFE,
304/316 stainless steel, polyethylene
Fluid fittings carbon steel
Fluid hose nylon

NOTE: all 304, 316 and 17-4 pH SST are electropolished and/or passivated.
Delrin® is a registered trademark of the Du Pont Company

The Graco Warranty and Disclaimers

WARRANTY

Graco warrants all equipment manufactured by it and bearing its name to be free from defects in fluid and workmanship on the date of sale by an authorized Graco distributor to the original purchaser for use. As purchaser's sole remedy for breach of this warranty, Graco will, for a period of twelve months from the date of sale, repair or replace any part of the equipment proven defective. This warranty applies only when the equipment is installed, operated and maintained in accordance with Graco's written recommendations.

This warranty does not cover, and Graco shall not be liable for, any malfunction, damage or wear caused by faulty installation, misapplication, abrasion, corrosion, inadequate or improper maintenance, negligence, accident, tampering, or substitution of non-Graco component parts. Nor shall Graco be liable for malfunction, damage or wear caused by the incompatibility with Graco equipment of structures, accessories, equipment or fluids not supplied by Graco, or the improper design, manufacture, installation, operation or maintenance of structures, accessories, equipment or fluids not supplied by Graco.

This warranty is conditioned upon the prepaid return of the equipment claimed to be defective to an authorized Graco distributor for verification of the claim. If the claimed defect is verified, Graco will repair or replace free of charge any defective parts. The equipment will be returned to the original purchaser transportation prepaid. If inspection of the equipment does not disclose any defect in fluid or workmanship, repairs will be made at a reasonable charge, which charges may include the costs of parts, labor and transportation.

DISCLAIMERS AND LIMITATIONS

The terms of this warranty constitute purchaser's sole and exclusive remedy and are in lieu of any other warranties (express or implied), **including warranty of merchantability or warranty of fitness for a particular purpose**, and of any non-contractual liabilities, including product liabilities, based on negligence or strict liability. Every form of liability for direct, special or consequential damages or loss is expressly excluded and denied. In no case shall Graco's liability exceed the amount of the purchase price. Any action for breach of warranty must be brought within two (2) years of the date of sale.

EQUIPMENT NOT COVERED BY GRACO WARRANTY

Graco makes no warranty, and disclaims all implied **warranties of merchantability and fitness for a particular purpose**, with respect to accessories, equipment, fluids, or components sold but not manufactured by Graco. These items sold, but not manufactured by Graco (such as electric motor, switches, hose, etc.) are subject to the warranty, if any, of their manufacturer. Graco will provide purchaser with reasonable assistance in making any claim for breach of these warranties.

Graco Phone Numbers

TO PLACE AN ORDER, contact your Graco distributor, or call this number to identify the distributor closest to you: **1-800-367-4023 Toll Free**

FOR TECHNICAL ASSISTANCE, service repair information or assistance regarding the application of Graco equipment: **1-800-543-0339 Toll Free**

Sales Offices: Atlanta, Chicago, Dallas, Detroit, Los Angeles, Mt. Arlington (N.J.)
Foreign Offices: Canada, England, Korea, Switzerland, France, Germany, Hong Kong, Japan

GRACO INC. P.O. BOX 1441 MINNEAPOLIS, MN 55440-1441

PRINTED IN U.S.A. 308-457 September, 1994, Revised November, 1994